



Level



Pressure



Flow



Temperature



Liquid
Analysis



Registration



Systems
Components



Services



Solutions

Operating Instructions

Proline Promag 53

Electromagnetic Flow Measuring System

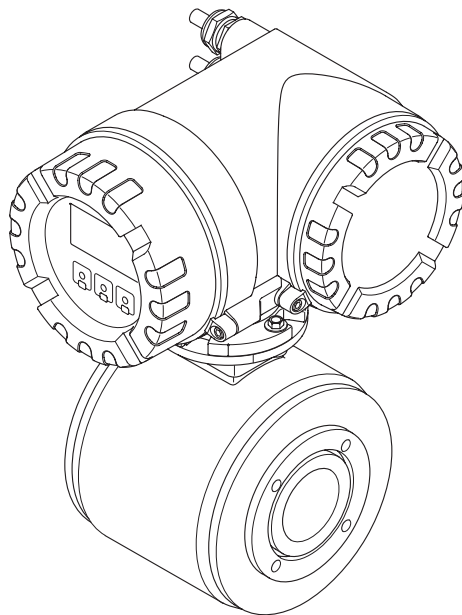
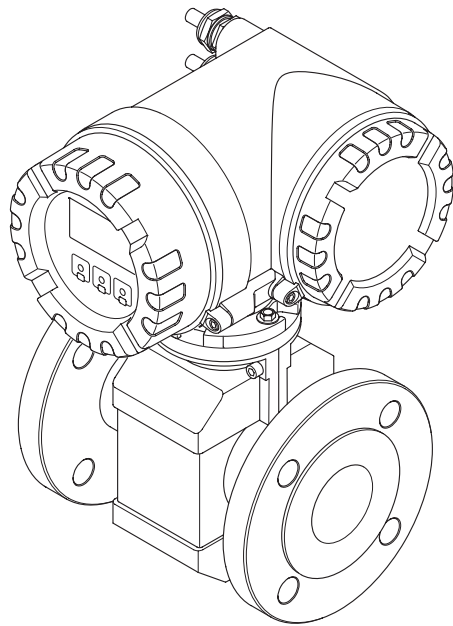

BA047D/06/EN/12.09
71107993

Valid as of version:
V 2.02.XX (device software)

Table of contents

1	Safety instructions	5	4.5	Post-connection check	52
1.1	Designated use	5	5	Operation	53
1.2	Installation, commissioning and operation	5	5.1	Display and operating elements	53
1.3	Operational safety	5	5.1.1	Display (operating mode)	54
1.4	Return	6	5.1.2	Additional display functions	54
1.5	Notes on safety conventions and icons	6	5.1.3	Controlling the batching processes using the local display	56
2	Identification	7	5.2	Brief Operating Instructions for the function matrix	57
2.1	Device designation	7	5.2.1	General notes	58
2.1.1	Nameplate of the transmitter	7	5.2.2	Enabling the programming mode	58
2.1.2	Nameplate of the sensor	8	5.2.3	Disabling the programming mode	58
2.1.3	Nameplate for connections	9	5.3	Error messages	59
2.2	Certificates and approvals	10	5.3.1	Type of error	59
2.3	Registered trademarks	10	5.3.2	Error message type	59
3	Installation	11	5.3.3	Confirming error messages	60
3.1	Incoming acceptance, transport and storage	11	5.4	Communication	60
3.1.1	Incoming acceptance	11	5.4.1	Operating options	61
3.1.2	Transport	11	5.4.2	Current device description files	62
3.1.3	Storage	12	5.4.3	Device and process variables	62
3.2	Installation conditions	13	5.4.4	Universal/Common practice	
3.2.1	Dimensions	13		HART commands	63
3.2.2	Mounting location	13	5.4.5	Device status/Error messages	67
3.2.3	Orientation	15	5.4.6	Switching HART write protection on and off	71
3.2.4	Inlet and outlet runs	16	6	Commissioning	72
3.2.5	Vibrations	16	6.1	Function check	72
3.2.6	Foundations, supports	17	6.2	Switching on the measuring device	72
3.2.7	Adapters	17	6.3	Quick Setup	73
3.2.8	Nominal diameter and flow rate	18	6.3.1	"Commissioning" Quick Setup menu	73
3.2.9	Length of connecting cable	20	6.3.2	"Pulsating flow" Quick Setup menu	75
3.3	Installation	21	6.3.3	"Batching" Quick Setup menu	78
3.3.1	Installing the Promag W sensor	21	6.3.4	Data backup/transmission	81
3.3.2	Installing the Promag P sensor	27	6.4	Configuration	82
3.3.3	Installing the Promag H sensor	32	6.4.1	Current outputs: active/passive	82
3.3.4	Turning the transmitter housing	35	6.4.2	Current input: active/passive	84
3.3.5	Turning the local display	36	6.4.3	Relay contacts: Normally closed/ normally open	85
3.3.6	Installing the wall-mount housing	37	6.5	Adjustment	86
3.4	Post-installation check	39	6.5.1	Empty-pipe/Full-pipe adjustment	86
4	Wiring	40	6.6	Data storage devices	87
4.1	Connecting the remote version	40	6.6.1	HistoROM/S-DAT (sensor DAT)	87
4.1.1	Connecting the sensor	40	6.6.2	HistoROM/T-DAT (transmitter DAT)	87
4.1.2	Cable specifications	44	6.6.3	F-CHIP (function chip)	87
4.2	Connecting the measuring unit	45	7	Maintenance	88
4.2.1	Connecting the transmitter	45	7.1	Exterior cleaning	88
4.2.2	Terminal assignment	47	7.2	Seals	88
4.2.3	HART connection	48	8	Accessories	89
4.3	Potential equalization	49	8.1	Device-specific accessories	89
4.3.1	Potential equalization, Promag W, Promag P	49	8.2	Accessories specific to measuring principle	89
4.3.2	Potential equalization, Promag H	49	8.3	Communication-specific accessories	90
4.3.3	Connection examples for potential equalization	49			
4.4	Degree of protection	51			

8.4	Service-specific accessories	91
9	Troubleshooting	92
9.1	Troubleshooting instructions	92
9.2	System error messages	93
9.3	Process error messages	96
9.4	Process errors without messages	98
9.5	Response of outputs to errors	99
9.6	Spare parts	101
9.6.1	Removing and installing electronics boards	102
9.6.2	Replacing the device fuse	106
9.6.3	Replacing the exchangeable electrode ...	107
9.7	Return	109
9.8	Disposal	109
9.9	Software history	109
10	Technical data	111
10.1	Technical data at a glance	111
10.1.1	Application	111
10.1.2	Function and system design	111
10.1.3	Input	111
10.1.4	Output	111
10.1.5	Power supply	112
10.1.6	Performance characteristics	113
10.1.7	Operating conditions: Installation	114
10.1.8	Operating conditions: Environment	114
10.1.9	Operating conditions: Process	115
10.1.10	Mechanical construction	119
10.1.11	Human interface	126
10.1.12	Certificates and approvals	126
10.1.13	Ordering information	128
10.1.14	Accessories	128
10.1.15	Documentation	128
Index	Index	129

1 Safety instructions

1.1 Designated use

The measuring device described in this Operating Manual is to be used only for measuring the flow rate of conductive fluids in closed pipes.

A minimum conductivity of 20 $\mu\text{S}/\text{cm}$ is required for measuring demineralized water. Most liquids can be measured as of a minimum conductivity of 5 $\mu\text{S}/\text{cm}$.

Examples:

- Acids, alkalis,
- Drinking water, wastewater, sewage sludge,
- Milk, beer, wine, mineral water, etc.

Resulting from incorrect use or from use other than that designated the operational safety of the measuring devices can be suspended. The manufacturer accepts no liability for damages being produced from this.



1.2 Installation, commissioning and operation

Note the following points:

- Installation, connection to the electricity supply, commissioning and maintenance of the device must be carried out by trained, qualified specialists authorized to perform such work by the facility's owner-operator. The specialist must have read and understood these Operating Instructions and must follow the instructions they contain.
- The device must be operated only by persons authorized and trained by the system operator. Strict compliance with the instructions in the Operating Instructions is mandatory.
- Endress+Hauser is willing to assist in clarifying the chemical resistance properties of parts wetted by special fluids, including fluids used for cleaning. However, small changes in temperature, concentration or the degree of contamination in the process can result in changes to the chemical resistance properties. For this reason, Endress+Hauser does not accept any responsibility with regard to the corrosion resistance of materials wetted by fluids in a specific application. The user is responsible for the choice of wetted materials with regard to their in-process resistance to corrosion.
- If welding work is performed on the piping system, do not ground the welding appliance through the flowmeter.
- The installer must ensure that the measuring system is correctly wired in accordance with the wiring diagrams. The transmitter must be grounded, except in cases where special protective measures have been taken (e.g. galvanically isolated power supply SELV or PELV).
- Always note the regulations applicable in your country to the operation, maintenance and repair of electrical devices. Special instructions relating to the device can be found in the relevant sections of the documentation.

1.3 Operational safety

Note the following points:

- Measuring systems for use in hazardous environments are accompanied by separate "Ex documentation", which is an integral part of these Operating Instructions. Strict compliance with the installation instructions and ratings as stated in this supplementary documentation is mandatory. Depending on the approval and certification agency, the relevant symbol is depicted on the front page of the supplementary documentation on Ex ratings (e.g.  Europe,  USA,  Canada).
- The measuring device meets the general safety requirements according to EN 61010-1 and the EMC requirements according to IEC/EN 61326 in addition to the NAMUR recommendations NE 21, NE 43 and NE 53.
- Depending on the application, the seals of the process connections of the Promag H sensor require periodic replacement.

- When hot fluid passes through the measuring tube, the surface temperature of the housing increases. In the case of the sensor, in particular, users should expect temperatures that can be close to the fluid temperature. If the temperature of the fluid is high, implement sufficient measures to prevent burning or scalding.
- The manufacturer reserves the right to modify technical data without prior notice. Your Endress+Hauser distributor will supply you with current information and updates to these Operating Instructions.

1.4 Return

- Do not return a measuring device if you are not absolutely certain that all traces of hazardous substances have been removed, e.g. substances which have penetrated crevices or diffused through plastic.
- Costs incurred for waste disposal and injury (burns, etc.) due to inadequate cleaning will be charged to the owner-operator.
- Please note the measures on →  109

1.5 Notes on safety conventions and icons

The devices are designed and tested to meet state-of-the-art safety requirements, and have left the factory in a condition in which they are safe to operate. The devices comply with the applicable standards and regulations in accordance with EN 61010 -1 "Protection Measures for Electrical Equipment for Measurement, Control, Regulation and Laboratory Procedures". The devices can, however, be a source of danger if used incorrectly or for other than the designated use. For this reason, always pay particular attention to the safety instructions indicated in these Operating Instructions by the following icons:



Warning!

"Warning" indicates an action or procedure which, if not performed correctly, can result in personal injury or a safety hazard. Comply strictly with the instructions and proceed with care.



Caution!

"Caution" indicates an action or procedure which, if not performed correctly, can result in incorrect operation or destruction of the device. Comply strictly with the instructions.



Note!

"Note" indicates an action or procedure which, if not performed correctly, can have an indirect effect on operation or trigger an unexpected response on the part of the device.

2 Identification

2.1 Device designation

The flow measuring system consists of the following components:

- Promag 53 transmitter
- Promag W, Promag P or Promag H sensors

Two versions are available:

- Compact version: transmitter and sensor form a single mechanical unit.
- Remote version: transmitter and sensor are installed separately.

2.1.1 Nameplate of the transmitter

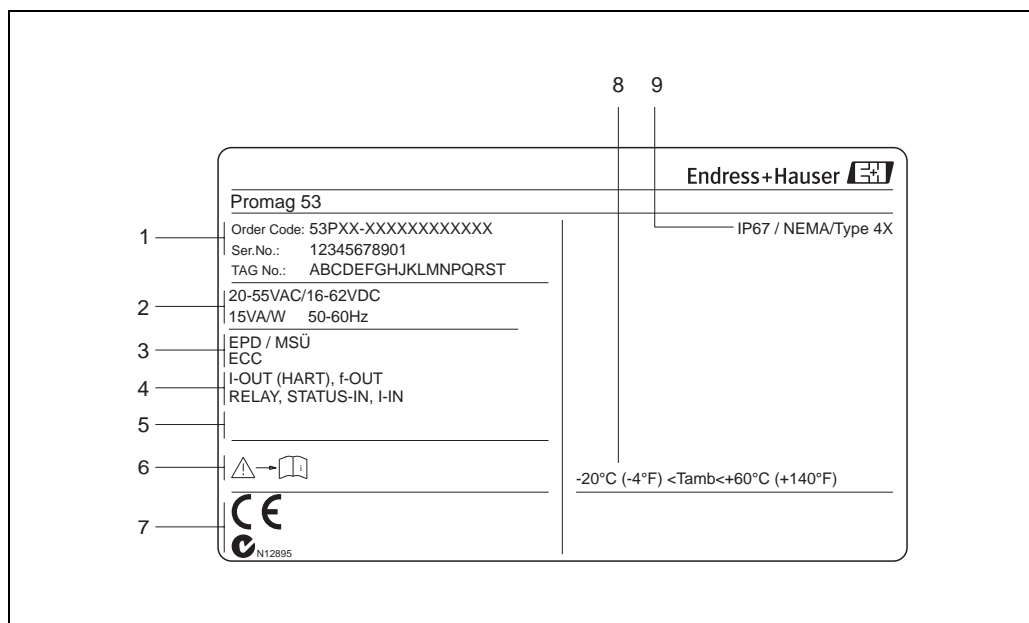

Fig. 1: Nameplate specifications for the "Promag 53" transmitter (example)

- 1 Order code/serial number: See the specifications on the order confirmation for the meanings of the individual letters and digits
- 2 Power supply/frequency/power consumption
- 3 Additional functions and software
 - EPD: with empty pipe detection electrode
 - ECC: with electrode cleaning
- 4 Available outputs:
 - I-OUT (HART): with current output (HART)
 - f-OUT: with pulse/frequency output
 - RELAY: with relay output
 - STATUS-IN: with status input (auxiliary input)
 - I-IN: with current input
- 5 Reserved for additional information on special products
- 6 Please comply with the Operating Instructions
- 7 Reserved for additional information on device version (approvals, certificates)
- 8 Permitted ambient temperature range
- 9 Degree of protection

2.1.2 Nameplate of the sensor

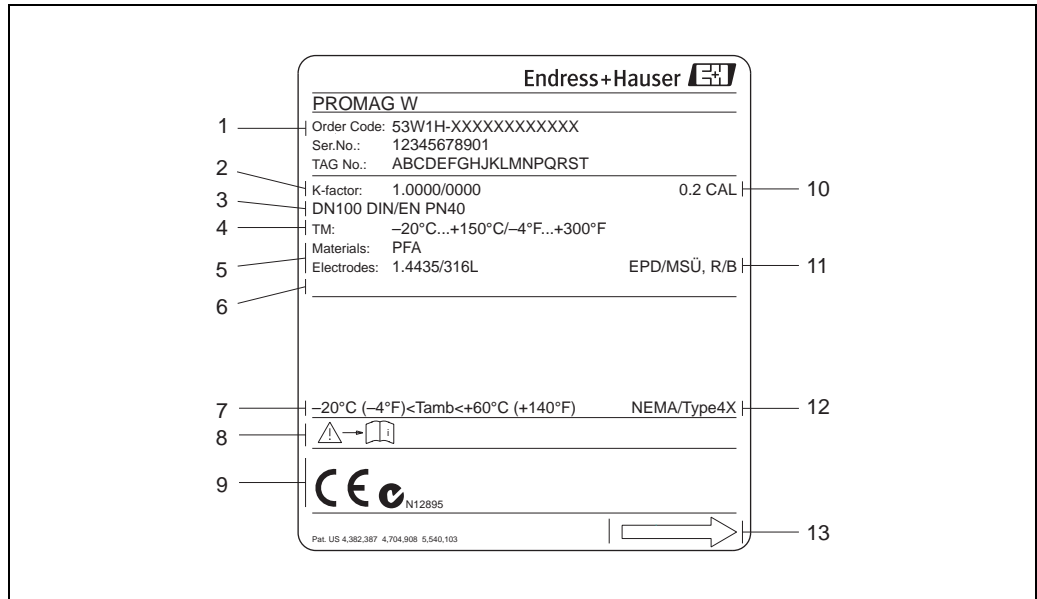

Fig. 2: Nameplate specifications for the "Promag W" sensor (example)

- 1 Order code/serial number: See the specifications on the order confirmation for the meanings of the individual letters and digits
- 2 Calibration factor with zero point
- 3 Nominal diameter/nominal pressure
- 4 Medium temperature range
- 5 Materials: lining/measuring electrode
- 6 Reserved for additional information on special products
- 7 Permitted ambient temperature range
- 8 Please comply with the Operating Instructions
- 9 Reserved for additional information on device version (approvals, certificates)
- 10 Calibration tolerance
- 11 Additional information
 - EPD: with empty pipe detection electrode
 - R/B: with reference electrode
- 12 Degree of protection
- 13 Flow direction

2.1.3 Nameplate for connections

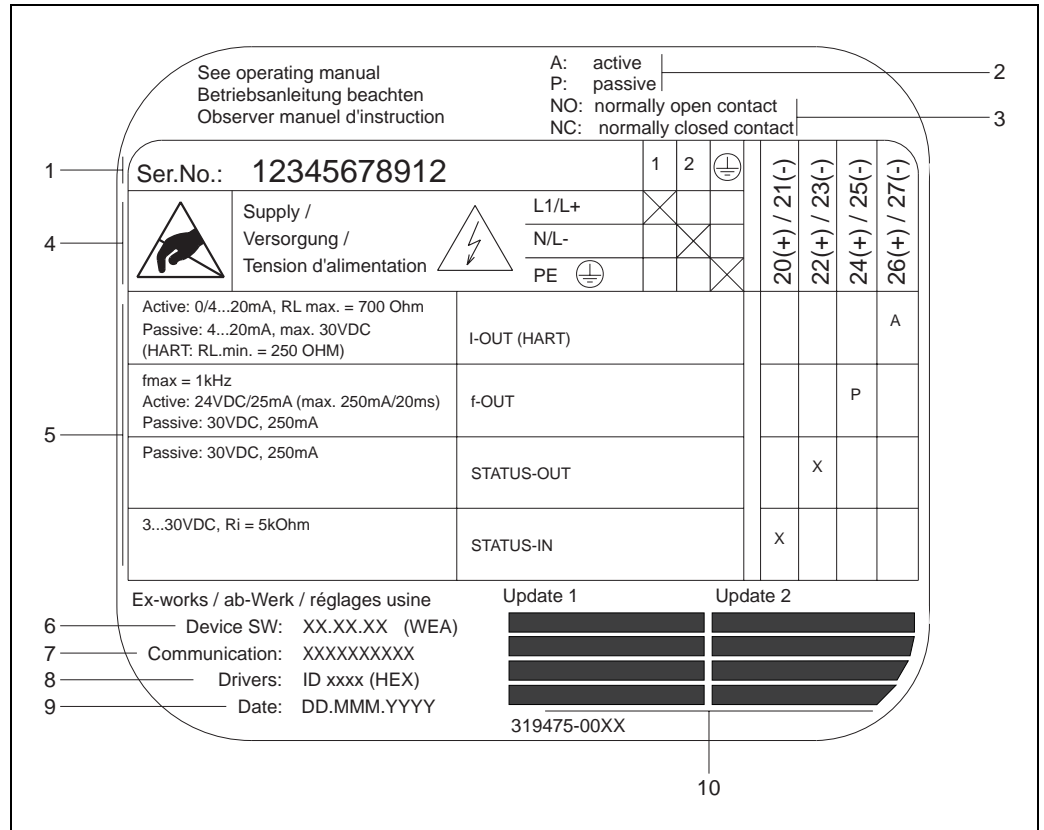

Fig. 3: Nameplate specifications for Proline transmitter connections (example)

- 1 Serial number
- 2 Possible configuration of current output
- 3 Possible configuration of relay contacts
- 4 Terminal assignment, cable for power supply
- Terminal **no. 1**:
– L1 for AC, L+ for DC
- Terminal **no. 2**:
– N for AC, L- for DC
- 5 Signals present at inputs and outputs, possible configurations and terminal assignment
- 6 Version of device software currently installed (incl. language group)
- 7 Type of communication installed
- 8 Information on current communication software (Device Revision, Device Description)
- 9 Date of installation
- 10 Current updates to data specified in points 6 to 9

2.2 Certificates and approvals

The devices are designed and tested to meet state-of-the-art safety requirements in accordance with sound engineering practice. They have left the factory in a condition in which they are safe to operate. The devices comply with the standards EN 61010 -1 "Protection Measures for Electrical Equipment for Measurement, Control, Regulation and Laboratory Procedures" and with the EMC requirements of IEC/EN 61326.

The measuring system described in these Operating Instructions therefore complies with the legal requirements of the EU Directives. Endress+Hauser confirms this by affixing the CE mark to it and by issuing the CE Declaration of Conformity.

The measuring system is in conformity with the EMC requirements of the "Australian Communications and Media Authority (ACMA)".

2.3 Registered trademarks

HART®

Registered trademark of HART Communication Foundation, Austin, USA

TRI-CLAMP®

Registered trademark of Ladish & Co., Inc., Kenosha, USA

KALREZ® and VITON®

Registered trademarks of E.I. Du Pont de Nemours & Co., Wilmington, USA

HistoROM™, S-DAT®, T-DAT™, F-CHIP®, Field Xpert™, FieldCare®, Fieldcheck®, Applicator®

Registered or registration-pending trademarks of Endress+Hauser Flowtec AG, Reinach, CH

3 Installation

3.1 Incoming acceptance, transport and storage

3.1.1 Incoming acceptance

On receipt of the goods, check the following points:

- Check the packaging and the contents for damage.
- Check the shipment, make sure nothing is missing and that the scope of supply matches your order.

3.1.2 Transport

The following instructions apply to unpacking and to transporting the device to its final location:

- Transport the devices in the containers in which they are delivered.
- Do not remove the protection plates or caps on the process connections until you are ready to install the device. This is particularly important in the case of sensors with PTFE linings.

Special notes on flanged devices



Caution!

- The wooden covers mounted on the flanges before the device leaves the factory protect the linings on the flanges during storage and transportation. Do not remove these protection plates until *immediately before* the device is installed in the pipe.
- Do not lift flanged devices by the transmitter housing or, in the case of the remote version, by the connection housing.

Transporting flanged devices (DN ≤ 300) 12"

Use webbing slings slung round the two process connections. Do not use chains, as they could damage the housing.



Warning!

Risk of injury if the measuring device slips. The center of gravity of the assembled measuring device might be higher than the points around which the slings are slung. At all times, therefore, make sure that the device does not unexpectedly turn around its axis or slip.

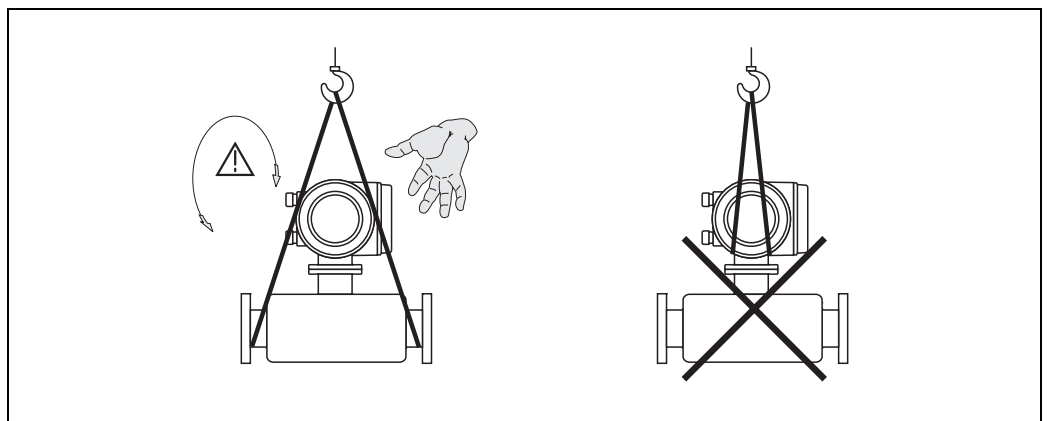

Fig. 4: Transporting sensors with DN ≥ 300 (12")

a0004294

Transporting flanged devices DN 300 (12")

Use only the metal eyes on the flanges for transporting the device, lifting it and positioning the sensor in the piping.



Caution!

Do not attempt to lift the sensor with the tines of a fork-lift truck beneath the metal casing. This would buckle the casing and damage the internal magnetic coils.

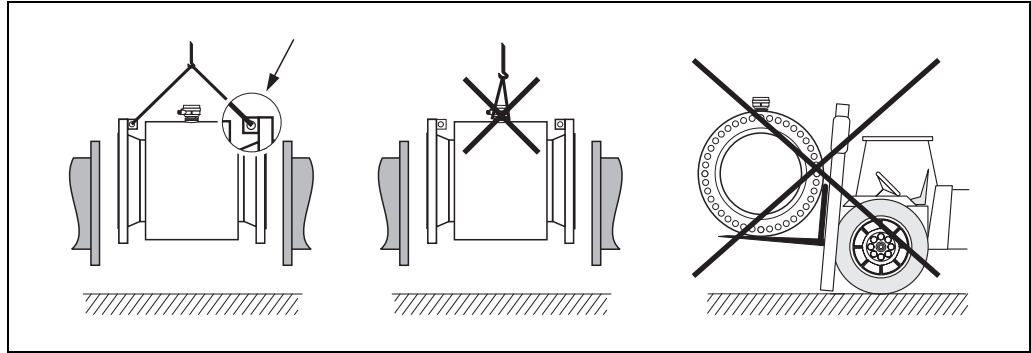

Fig. 5: Transporting sensors with DN > 300 (12")

3.1.3 Storage

Note the following points:

- Pack the measuring device in such a way as to protect it reliably against impact for storage (and transportation). The original packaging provides optimum protection.
- The storage temperature corresponds to the operating temperature range of the measuring transmitter and the appropriate measuring sensors → 114.
- The measuring device must be protected against direct sunlight during storage in order to avoid unacceptably high surface temperatures.
- Choose a storage location where moisture does not collect in the measuring device. This will help prevent fungus and bacteria infestation which can damage the lining.
- Do not remove the protection plates or caps on the process connections until you are ready to install the device. This is particularly important in the case of sensors with PTFE linings.

3.2 Installation conditions

3.2.1 Dimensions

The dimensions and installation lengths of the sensor and transmitter can be found in the "Technical Information" for the device in question. This document can be downloaded as a PDF file from www.endress.com. A list of the "Technical Information" documents available is provided in the "Documentation" section on → [128](#).

3.2.2 Mounting location

The accumulation of air or gas bubbles in the measuring tube could result in an increase in measuring errors.

Avoid the following locations:

- At the highest point of a pipeline. Risk of air accumulating.
- Directly upstream from a free pipe outlet in a vertical pipeline.

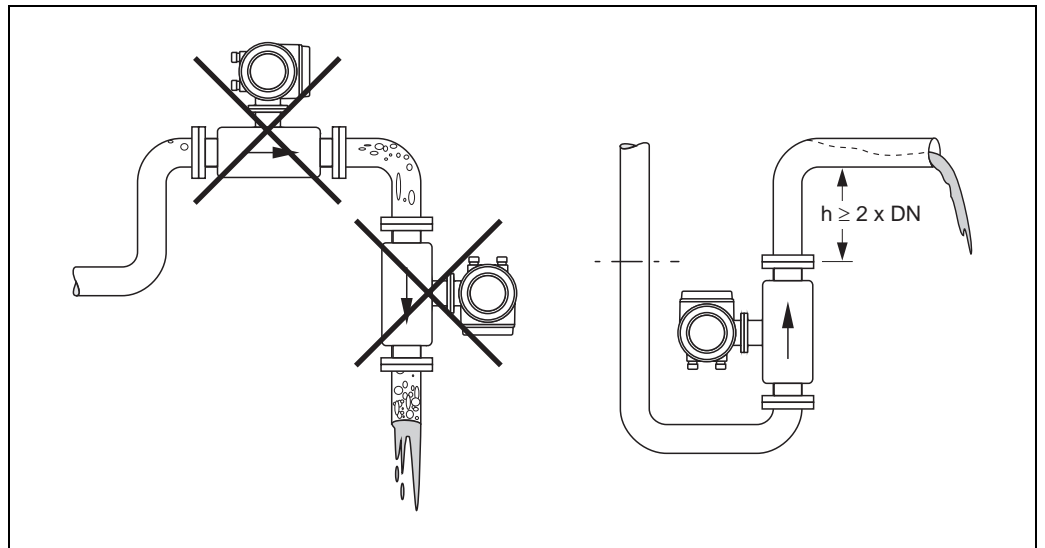

Fig. 6: Mounting location

Installing pumps

Do not install the sensor on the intake side of a pump. This precaution is to avoid low pressure and the consequent risk of damage to the lining of the measuring tube. Information on the lining's resistance to partial vacuum → [117](#).

It might be necessary to install pulse dampers in systems incorporating reciprocating, diaphragm or peristaltic pumps. Information on the measuring system's resistance to vibration and shock → [114](#).

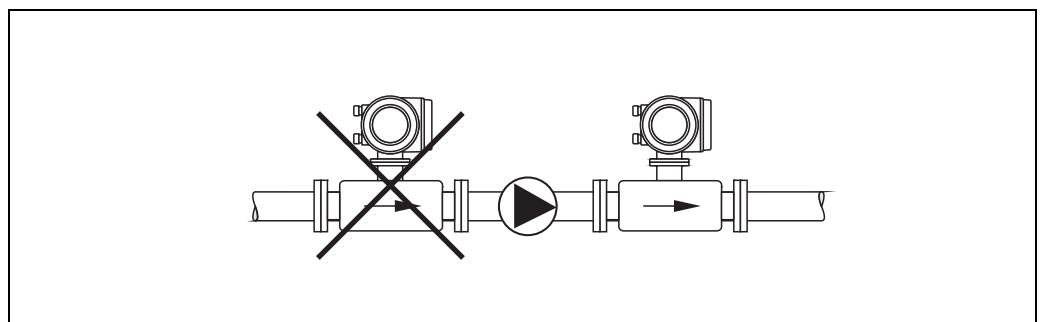

Fig. 7: Installing pumps

Partially filled pipes

Partially filled pipes with gradients necessitate a drain-type configuration. The Empty Pipe Detection function offers additional protection by detecting empty or partially filled pipes → 86.



Caution!

Risk of solids accumulating. Do not install the sensor at the lowest point in the drain. It is advisable to install a cleaning valve.

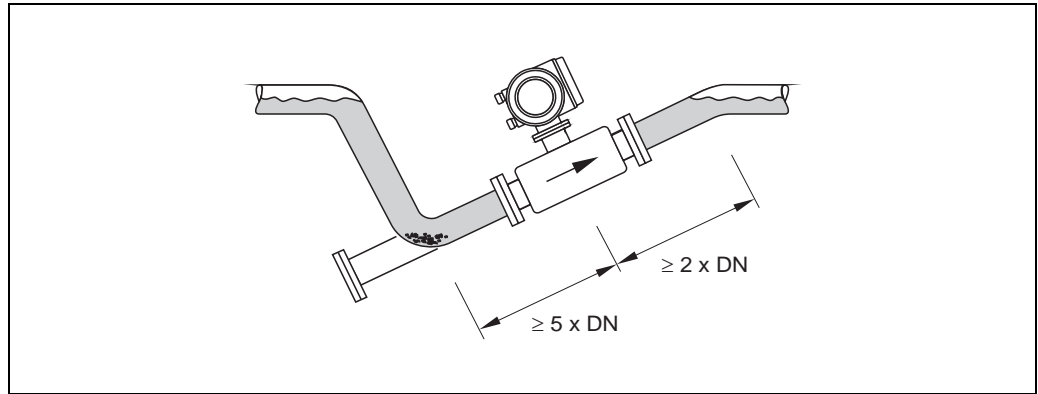

Fig. 8: Installation in partially filled pipe

Down pipes

Install a siphon or a vent valve downstream of the sensor in down pipes longer than 5 meters (16,3 ft). This precaution is to avoid low pressure and the consequent risk of damage to the lining of the measuring tube. This measure also prevents the system losing prime, which could cause air inclusions.

Information on the lining's resistance to partial vacuum → 117

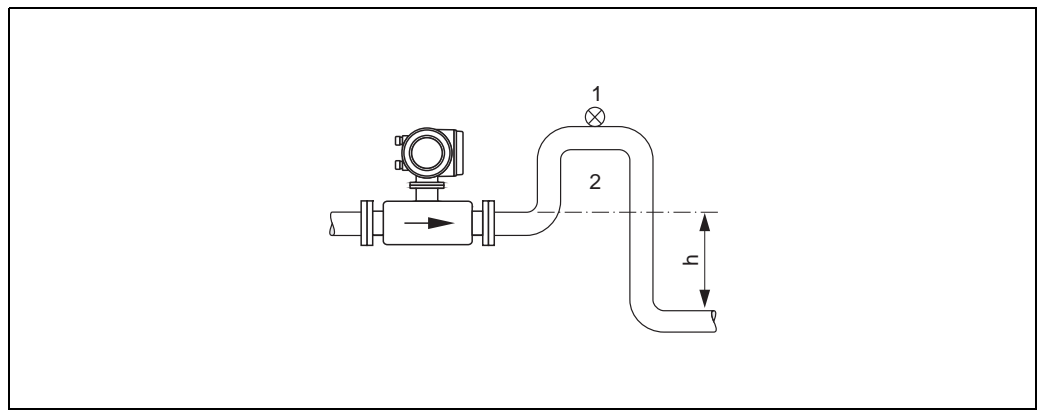

Fig. 9: Measures for installation in a down pipe

- 1 Vent valve
- 2 Siphon
- h Length of down pipe ($h \geq 5 \text{ m (16,3 ft)}$)

3.2.3 Orientation

An optimum orientation position helps avoid gas and air accumulations and deposits in the measuring tube. Promag, nevertheless, supplies a range of functions and accessories for correct measuring of problematic fluids:

- Electrode Cleaning Circuitry (ECC) to prevent electrically conductive deposits in the measuring tube, e.g. for fluids causing buildup (see "Description of Device Functions" manual).
- Empty Pipe Detection (EPD) ensures the detection of partially filled measuring tubes or in the case of degassing fluids → 86.

Vertical orientation

A vertical orientation is ideal in the following cases:

- For self-emptying piping systems and when using empty pipe detection.
- For sludge containing sand or stones and where the solids cause sedimentation.

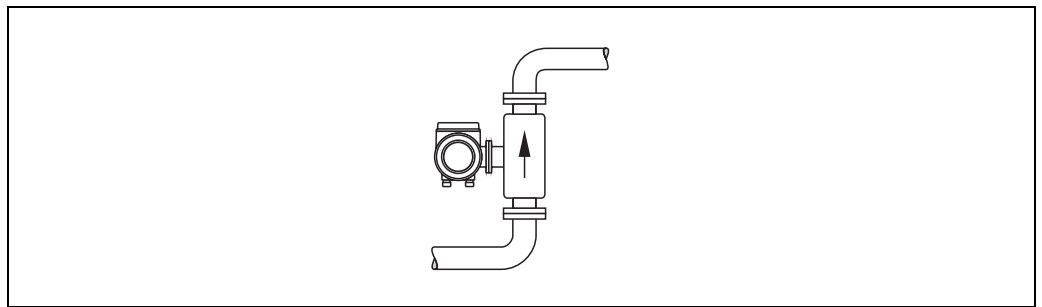

Fig. 10: Vertical orientation

Horizontal orientation

The measuring electrode plane should be horizontal. This prevents brief insulation of the two electrodes by entrained air bubbles.



Caution!

Empty Pipe Detection functions correctly with the measuring device installed horizontally only when the transmitter housing is facing upward (see diagram). Otherwise there is no guarantee that Empty Pipe Detection will respond if the measuring tube is only partially filled.

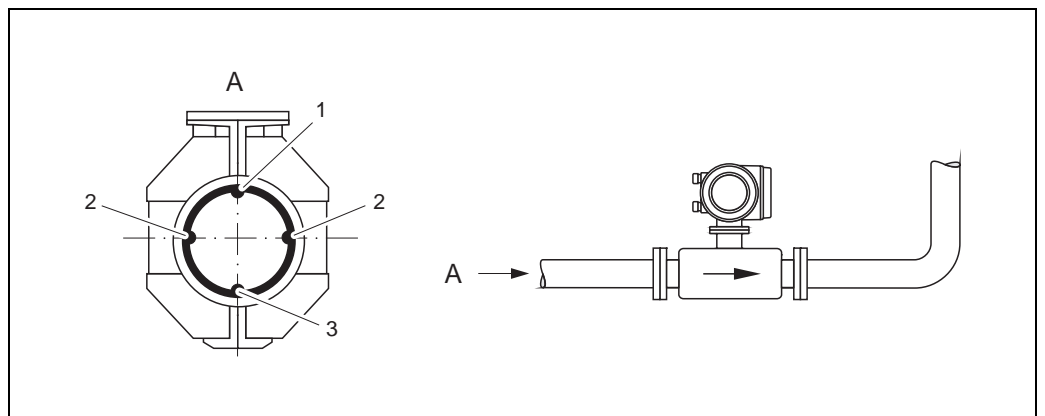

Fig. 11: Horizontal orientation

- 1 EPD electrode for empty pipe detection
(not available for "measuring electrode only" option, not in Promag H, DN 2 to 15 (1/12" to 1/2"))
- 2 Measuring electrodes for signal detection
- 3 Reference electrode for potential equalization
(not available for "measuring electrode only" option, not in Promag H)

3.2.4 Inlet and outlet runs

If possible, install the sensor in a location upstream of fittings such as valves, T-pieces, elbows, etc.

Compliance with the following requirements for the inlet and outlet runs is necessary in order to ensure measuring accuracy.

- Inlet run $\geq 5 \times \text{DN}$
- Outlet run $\geq 2 \times \text{DN}$

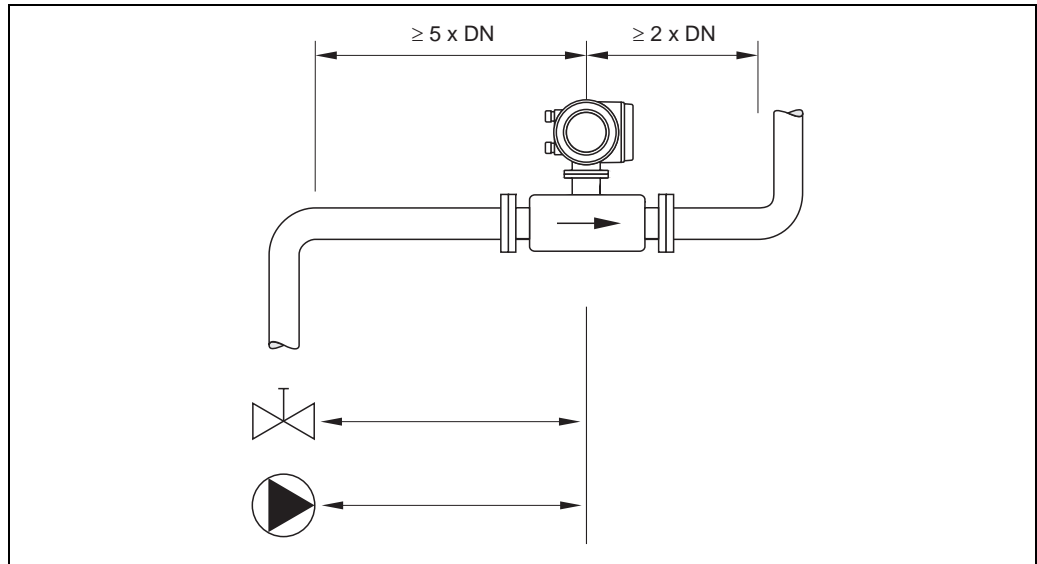

Fig. 12: Inlet and outlet runs

3.2.5 Vibrations

Secure and fix both the piping and the sensor if the vibrations are severe.



Caution!

It is advisable to install sensor and transmitter separately if vibration is excessively severe.

Information on the permitted resistance to vibration and shock → [114](#).

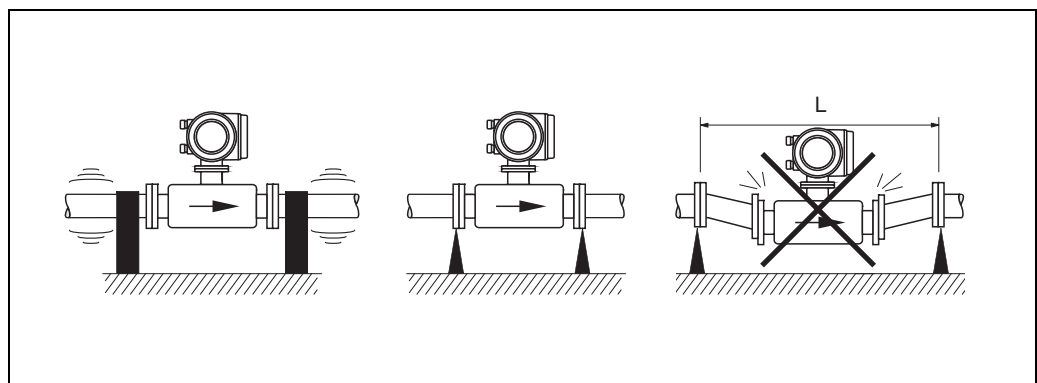

Fig. 13: Measures to prevent vibration of the measuring device ($L > 10 \text{ m}/33 \text{ ft}$)

3.2.6 Foundations, supports

If the nominal diameter is $DN \geq 350$ (14"), mount the sensor on a foundation of adequate load-bearing strength.



Caution!

Risk of damage.

Do not support the weight of the sensor on the metal casing; the casing would buckle and damage the internal magnetic coils.

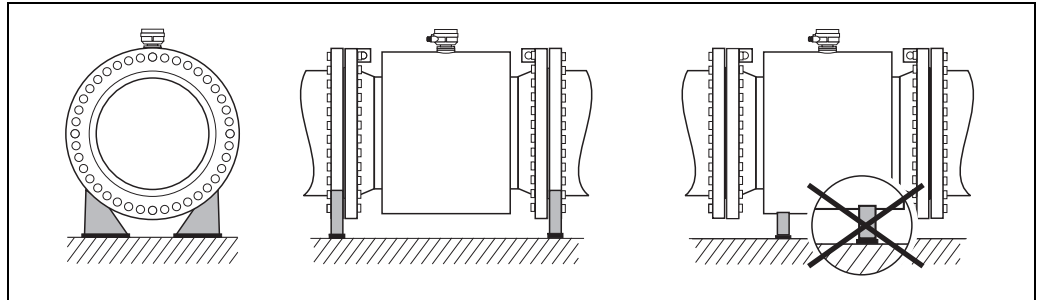

Fig. 14: Correct support for large nominal diameters ($DN \geq 350/14''$)

3.2.7 Adapters

Suitable adapters to DIN EN 545 (double-flange reducers) can be used to install the sensor in larger-diameter pipes. The resultant increase in the rate of flow improves measuring accuracy with very slow-moving fluids.

The nomogram shown here can be used to calculate the pressure loss caused by cross-section reduction.



Note!

The nomogram only applies to liquids of viscosity similar to water.

1. Calculate the ratio of the diameters d/D .
2. From the nomogram, read off the pressure loss as a function of fluid velocity (*downstream* from the reduction) and the d/D ratio.

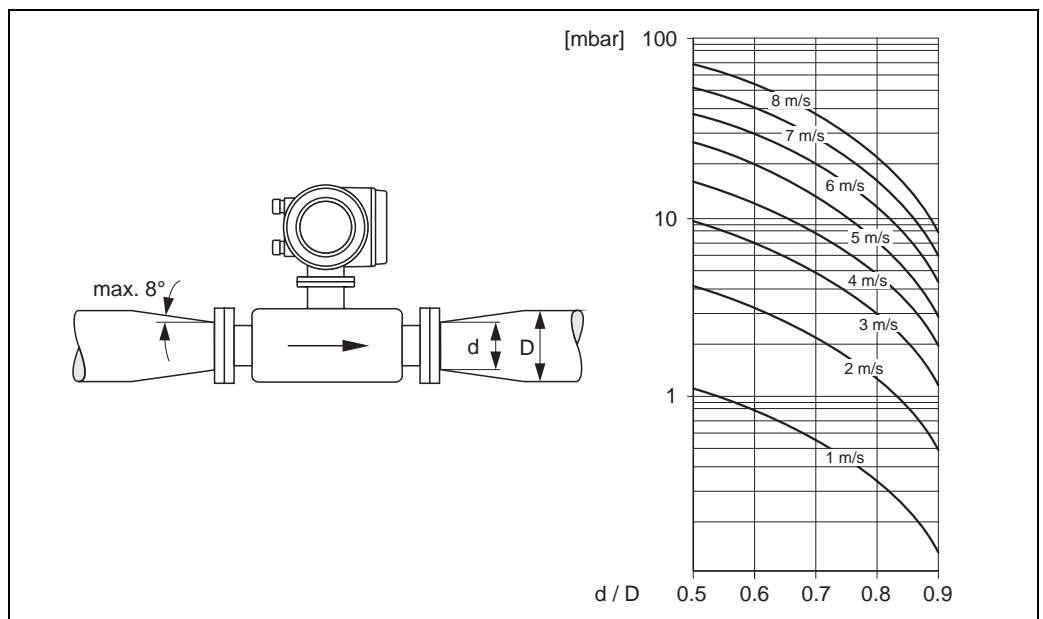

Fig. 15: Pressure loss due to adapters

3.2.8 Nominal diameter and flow rate

The diameter of the pipe and the flow rate determine the nominal diameter of the sensor. The optimum velocity of flow is between 2 and 3 m/s (6.5 to 9.8 ft/s)

The velocity of flow (v), moreover, has to be matched to the physical properties of the fluid:

- $v < 2$ m/s ($v < 6.5$ ft/s): for abrasive fluids
- $v > 2$ m/s ($v > 6.5$ ft/s): for fluids producing buildup



Note!

Flow velocity can be increased, if necessary, by reducing the nominal diameter of the sensor (→ 17).

Recommended flow (SI units)



Nominal diameter [mm]	Promag W	Promag P	Promag H
	Min./max. full scale value ($v \approx 0.3$ or 10 m/s) in [dm ³ /min]		
2	–	–	0.06 to 1.8
4	–	–	0.25 to 7
8	–	–	1 to 30
15	–	4 to 100	4 to 100
25	9 to 300	9 to 300	9 to 300
32	15 to 500	15 to 500	–
40	25 to 700	25 to 700	25 to 700
50	35 to 1100	35 to 1100	35 to 1100
65	60 to 2000	60 to 2000	60 to 2000
80	90 to 3000	90 to 3000	90 to 3000
100	145 to 4700	145 to 4700	145 to 4700
125	220 to 7500	220 to 7500	–
[mm]	Min./max. full scale value ($v \approx 0.3$ or 10 m/s) in [m ³ /h]		
150	20 to 600	20 to 600	–
200	35 to 1100	35 to 1100	–
250	55 to 1700	55 to 1700	–
300	80 to 2400	80 to 2400	–
350	110 to 3300	110 to 3300	–
375	140 to 4200	–	–
400	140 to 4200	140 to 4200	–
450	180 to 5400	180 to 5400	–
500	220 to 6600	220 to 6600	–
600	310 to 9600	310 to 9600	–
700	420 to 13500	–	–
800	550 to 18000	–	–
900	690 to 22500	–	–
1000	850 to 28000	–	–
1200	1250 to 40000	–	–
1400	1700 to 55000	–	–
1600	2200 to 70000	–	–
1800	2800 to 90000	–	–
2000	3400 to 110000	–	–

Recommended flow (US units)

Nominal diameter [inch]	Promag W	Promag P	Promag H
	Min./max. full scale value (v ≈ 0.3 or 10 m/s) in [gal/min]		
1 1/12"	–	–	0.015 to 0.5
5/32"	–	–	0.07 to 2
5/16"	–	–	0.25 to 8
1/2"	–	1.0 to 27	1.0 to 27
1"	2.5 to 80	2.5 to 80	2.5 to 80
1 1/4"	4 to 130	4 to 130	–
1 1/2"	7 to 190	7 to 190	7 to 190
2"	10 to 300	10 to 300	10 to 300
2 1/2"	16 to 500	16 to 500	16 to 500
3"	24 to 800	24 to 800	24 to 800
4"	40 to 1250	40 to 1250	40 to 1250
5"	60 to 1950	60 to 1950	–
6"	90 to 2650	90 to 2650	–
8"	155 to 4850	155 to 4850	–
10"	250 to 7500	250 to 7500	–
12"	350 to 10600	350 to 10600	–
14"	500 to 15000	500 to 15000	–
15"	600 to 19000	–	–
16"	600 to 19000	600 to 19000	–
18"	800 to 24000	800 to 24000	–
20"	1000 to 30000	1000 to 30000	–
24"	1400 to 44000	1400 to 44000	–
28"	1900 to 60000	–	–
30"	2150 to 67000	–	–
32"	2450 to 80000	–	–
36"	3100 to 100000	–	–
40"	3800 to 125000	–	–
42"	4200 to 135000	–	–
48"	5500 to 175000	–	–
[inch]	Min./max. full scale value (v ≈ 0.3 or 10 m/s) in [Mgal/d]		
54"	9 to 300	–	–
60"	12 to 380	–	–
66"	14 to 500	–	–
72"	16 to 570	–	–
78"	18 to 650	–	–

3.2.9 Length of connecting cable

In order to ensure measuring accuracy, please comply with the following instructions when installing the remote version:

- Secure the cable run or route the cable in an armored conduit. Movement of the cable can falsify the measuring signal, particularly if the fluid conductivity is low.
- Route the cable well clear of electrical machines and switching elements.
- Ensure potential equalization between sensor and transmitter, if necessary.
- The permissible cable length L_{max} depends on the fluid conductivity (→  16).
- The maximum connecting cable length is 10 m (32.8 ft) when empty pipe detection (EPD →  86) is switched on.

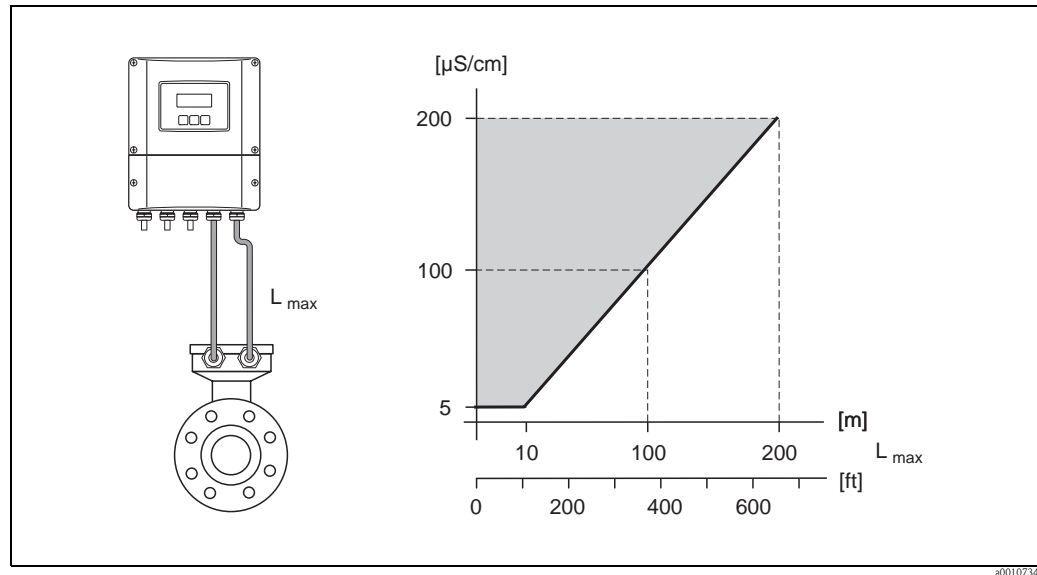

Fig. 16: Permitted lengths for connecting cable in remote version, as a function of the conductivity of the fluid

Gray shaded area = permissible range

L_{max} = length of connecting cable

3.3 Installation

3.3.1 Installing the Promag W sensor



Note!

Bolts, nuts, seals, etc. are not included in the scope of supply and must be supplied by the customer.

The sensor is designed for installation between the two piping flanges:

- It is essential that you observe the necessary screw tightening torques on → 22.
- If grounding disks are used, follow the mounting instructions which will be enclosed with the shipment.

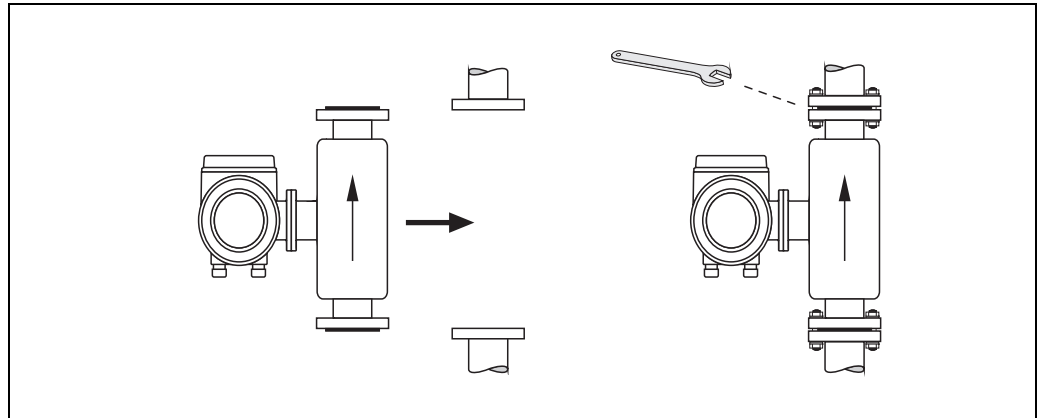

Fig. 17: Installing the Promag W sensor

A0011908

Seals

Comply with the following instructions when installing seals:

- Hard rubber lining → additional seals are **always** required.
- Polyurethane lining → seals are **not** required.
- Only use seals that comply with DIN EN 1514-1 for DIN flanges.
- Make sure that the seals do not protrude into the piping cross-section.



Caution!

Risk of short circuit! Do not use electrically conductive sealing compound such as graphite. An electrically conductive layer could form on the inside of the measuring tube and short-circuit the measuring signal.

Ground cable

- If necessary, special ground cables can be ordered as accessories for potential equalization, → 89.
- For information on potential equalization and detailed installation instructions for using ground cables, please refer to → 49.

Screw tightening torques (Promag W)

Note the following points:

- The tightening torques listed below are for lubricated threads only.
- Always tighten the screws uniformly and in diagonally opposite sequence.
- Overtightening the screws will deform the sealing faces or damage the seals.
- The tightening torques listed below apply only to pipes not subjected to tensile stress.

Tightening torques for:

- EN (DIN) → 22
- JIS → 24
- ANSI → 24
- AWWA → 25
- AS 2129 → 25
- AS 4087 → 26

Promag W tightening torques for EN (DIN)

Nominal diameter [mm]	EN (DIN) Pressure rating [bar]	Screws	Max. tightening torque [Nm]	
			Hard rubber	Polyurethane
25	PN 40	4 × M 12	-	15
32	PN 40	4 × M 16	-	24
40	PN 40	4 × M 16	-	31
50	PN 40	4 × M 16	-	40
65*	PN 16	8 × M 16	32	27
65	PN 40	8 × M 16	32	27
80	PN 16	8 × M 16	40	34
80	PN 40	8 × M 16	40	34
100	PN 16	8 × M 16	43	36
100	PN 40	8 × M 20	59	50
125	PN 16	8 × M 16	56	48
125	PN 40	8 × M 24	83	71
150	PN 16	8 × M 20	74	63
150	PN 40	8 × M 24	104	88
200	PN 10	8 × M 20	106	91
200	PN 16	12 × M 20	70	61
200	PN 25	12 × M 24	104	92
250	PN 10	12 × M 20	82	71
250	PN 16	12 × M 24	98	85
250	PN 25	12 × M 27	150	134
300	PN 10	12 × M 20	94	81
300	PN 16	12 × M 24	134	118
300	PN 25	16 × M 27	153	138
350	PN 6	12 × M 20	111	120
350	PN 10	16 × M 20	112	118
350	PN 16	16 × M 24	152	165
350	PN 25	16 × M 30	227	252
400	PN 6	16 × M 20	90	98
400	PN 10	16 × M 24	151	167
400	PN 16	16 × M 27	193	215
400	PN 25	16 × M 33	289	326
450	PN 6	16 × M 20	112	126
450	PN 10	20 × M 24	153	133
450	PN 16	20 × M 27	198	196
450	PN 25	20 × M 33	256	253
500	PN 6	20 × M 20	119	123
500	PN 10	20 × M 24	155	171

Nominal diameter [mm]	EN (DIN) Pressure rating [bar]	Screws	Max. tightening torque [Nm]	
			Hard rubber	Polyurethane
500	PN 16	20 × M 30	275	300
500	PN 25	20 × M 33	317	360
600	PN 6	20 × M 24	139	147
600	PN 10	20 × M 27	206	219
600 *	PN 16	20 × M 33	415	443
600	PN 25	20 × M 36	431	516
700	PN 6	24 × M 24	148	139
700	PN 10	24 × M 27	246	246
700	PN 16	24 × M 33	278	318
700	PN 25	24 × M 39	449	507
800	PN 6	24 × M 27	206	182
800	PN 10	24 × M 30	331	316
800	PN 16	24 × M 36	369	385
800	PN 25	24 × M 45	664	721
900	PN 6	24 × M 27	230	637
900	PN 10	28 × M 30	316	307
900	PN 16	28 × M 36	353	398
900	PN 25	28 × M 45	690	716
1000	PN 6	28 × M 27	218	208
1000	PN 10	28 × M 33	402	405
1000	PN 16	28 × M 39	502	518
1000	PN 25	28 × M 52	970	971
1200	PN 6	32 × M 30	319	299
1200	PN 10	32 × M 36	564	568
1200	PN 16	32 × M 45	701	753
1400	PN 6	36 × M 33	430	398
1400	PN 10	36 × M 39	654	618
1400	PN 16	36 × M 45	729	762
1600	PN 6	40 × M 33	440	417
1600	PN 10	40 × M 45	946	893
1600	PN 16	40 × M 52	1007	1100
1800	PN 6	44 × M 36	547	521
1800	PN 10	44 × M 45	961	895
1800	PN 16	44 × M 52	1108	1003
2000	PN 6	48 × M 39	629	605
2000	PN 10	48 × M 45	1047	1092
2000	PN 16	48 × M 56	1324	1261

* Designed acc. to EN 1092-1 (not to DIN 2501)

Promag W tightening torques for JIS

Sensor Nominal diameter [mm]	JIS Pressure rating	Screws	Max. tightening torque [Nm]	
			Hard rubber	Polyurethane
25	10K	4 × M 16	–	19
25	20K	4 × M 16	–	19
32	10K	4 × M 16	–	22
32	20K	4 × M 16	–	22
40	10K	4 × M 16	–	24
40	20K	4 × M 16	–	24
50	10K	4 × M 16	–	33
50	20K	8 × M 16	–	17
65	10K	4 × M 16	55	45
65	20K	8 × M 16	28	23
80	10K	8 × M 16	29	23
80	20K	8 × M 20	42	35
100	10K	8 × M 16	35	29
100	20K	8 × M 20	56	48
125	10K	8 × M 20	60	51
125	20K	8 × M 22	91	79
150	10K	8 × M 20	75	63
150	20K	12 × M 22	81	72
200	10K	12 × M 20	61	52
200	20K	12 × M 22	91	80
250	10K	12 × M 22	100	87
250	20K	12 × M 24	159	144
300	10K	16 × M 22	74	63
300	20K	16 × M 24	138	124

Promag W tightening torques for ANSI

Sensor Nominal diameter [inch]	ANSI Pressure rating [lbs]	Screws	Max. tightening torque [Nm]	
			Hard rubber	Polyurethane
1"	Class 150	4 × ½"	–	7
1"	Class 300	4 × 5/8"	–	8
1 ½"	Class 150	4 × ½"	–	10
1 ½"	Class 300	4 × ¾"	–	15
2"	Class 150	4 × 5/8"	–	22
2"	Class 300	8 × 5/8"	–	11
3"	Class 150	4 × 5/8"	60	43
3"	Class 300	8 × ¾"	38	26
4"	Class 150	8 × 5/8"	42	31
4"	Class 300	8 × ¾"	58	40
6"	Class 150	8 × ¾"	79	59
6"	Class 300	12 × ¾"	70	51
8"	Class 150	8 × ¾"	107	80
10"	Class 150	12 × 7/8"	101	75
12"	Class 150	12 × 7/8"	133	103
14"	Class 150	12 × 1"	135	158

Sensor Nominal diameter [inch]	ANSI Pressure rating [lbs]	Screws	Max. tightening torque [Nm]	
			Hard rubber	Polyurethane
16"	Class 150	16 × 1"	128	150
18"	Class 150	16 × 1 1/8"	204	234
20"	Class 150	20 × 1 1/8"	183	217
24"	Class 150	20 × 1 ¼"	268	307

Promag W tightening torques for AWWA

Sensor Nominal diameter [inch]	AWWA Pressure rating	Screws	Max. tightening torque [Nm]	
			Hard rubber	Polyurethane
28"	Class D	28 × 1 ¼"	247	292
30"	Class D	28 × 1 ¼"	287	302
32"	Class D	28 × 1 ½"	394	422
36"	Class D	32 × 1 ½"	419	430
40"	Class D	36 × 1 ½"	420	477
42"	Class D	36 × 1 ½"	528	518
48"	Class D	44 × 1 ½"	552	531
54"	Class D	44 × 1 ¾"	730	633
60"	Class D	52 × 1 ¾"	758	832
66"	Class D	52 × 1 ¾"	946	955
72"	Class D	60 × 1 ¾"	975	1087
78"	Class D	64 × 2"	853	786

Promag W tightening torques for AS 2129

Sensor Nominal diameter [mm]	AS 2129 Pressure rating	Screws	Max. tightening torque [Nm]
			Hard rubber
80	Table E	4 × M 16	49
100	Table E	8 × M 16	38
150	Table E	8 × M 20	64
200	Table E	8 × M 20	96
250	Table E	12 × M 20	98
300	Table E	12 × M 24	123
350	Table E	12 × M 24	203
400	Table E	12 × M 24	226
500	Table E	16 × M 24	271
600	Table E	16 × M 30	439
700	Table E	20 × M 30	355
750	Table E	20 × M 30	559
800	Table E	20 × M 30	631
900	Table E	24 × M 30	627
1000	Table E	24 × M 30	634
1200	Table E	32 × M 30	727

Promag W tightening torques for AS 4087

Sensor Nominal diameter [mm]	AS 4087 Pressure rating	Screws	Max. tightening torque [Nm]
			Hard rubber
80	PN 16	4 × M 16	49
100 *	PN 16	8 × M 16	38
150	PN 16	8 × M 20	52
200	PN 16	8 × M 20	77
250	PN 16	8 × M 20	147
300	PN 16	12 × M 24	103
350	PN 16	12 × M 24	203
375	PN 16	12 × M 24	137
400	PN 16	12 × M 24	226
500	PN 16	16 × M 24	271
600	PN 16	16 × M 30	393
700	PN 16	20 × M 27	330
750	PN 16	20 × M 30	529
800	PN 16	20 × M 33	631
900	PN 16	24 × M 33	627
1000	PN 16	24 × M 33	595
1200	PN 16	32 × M 33	703
* Designed acc. to AS 2129 (not to AS 4087)			

3.3.2 Installing the Promag P sensor



Caution!

- The protective covers mounted on the two sensor flanges guard the PTFE lining, which is turned over the flanges. Consequently, do not remove these protection plates **until immediately before** the sensor is installed in the pipe.
- Protection plates must remain in place while the device is in storage.
- Make sure that the lining is not damaged or removed from the flanges.



Note!

Bolts, nuts, seals, etc. are not included in the scope of supply and must be supplied by the customer.

The sensor is designed for installation between the two piping flanges:

- It is essential that you observe the necessary screw tightening torques on → [28](#).
- If grounding disks are used, follow the mounting instructions which will be enclosed with the shipment.

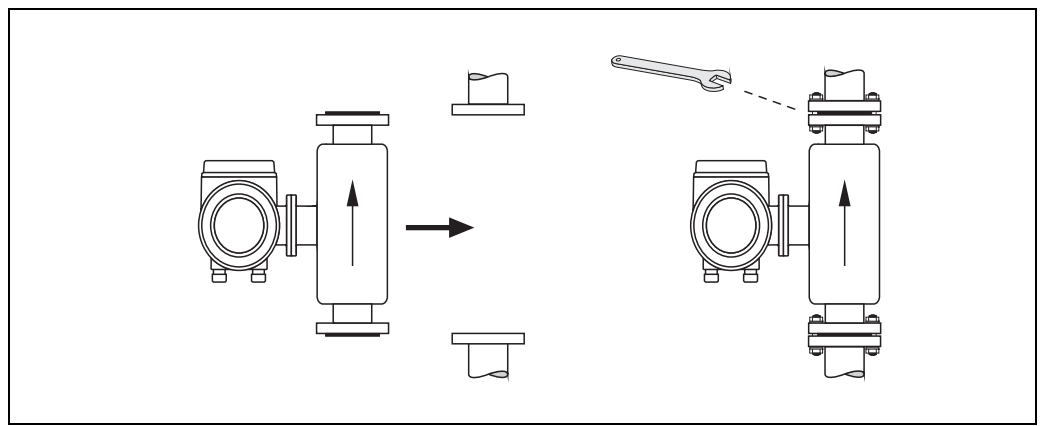

Fig. 18: Installing the Promag P sensor

Seals

Comply with the following instructions when installing seals:

- PFA or PTFE lining → seals are **not** required.
- Only use seals that comply with DIN EN 1514-1 for DIN flanges.
- Make sure that the seals do not protrude into the piping cross-section.



Caution!

Risk of short circuit! Do not use electrically conductive sealing compound such as graphite. An electrically conductive layer could form on the inside of the measuring tube and short-circuit the measuring signal.

Ground cable

- If necessary, special ground cables can be ordered as accessories for potential equalization, → [89](#).
- For information on potential equalization and detailed installation instructions for using ground cables, please refer to → [49](#).

Installing the high-temperature version (with PFA lining)

The high-temperature version has a housing support for the thermal separation of sensor and transmitter. The high-temperature version is always used for applications in which high ambient temperatures are encountered in conjunction with high fluid temperatures. The high-temperature version is obligatory if the fluid temperature exceeds +150 °C (+300 °F).



Note!

You will find information on permissible temperature ranges on → [115](#).

Insulation

Pipes generally have to be insulated if they carry very hot fluids to avoid energy losses and prevent accidental contact with pipes at temperatures that could cause injury. Guidelines regulating the insulation of pipes have to be taken into account.



Caution!

Risk of electronics overheating. The housing support dissipates heat and its entire surface area must remain uncovered. Make sure that the sensor insulation does not extend past the top of the two sensor half-shells.

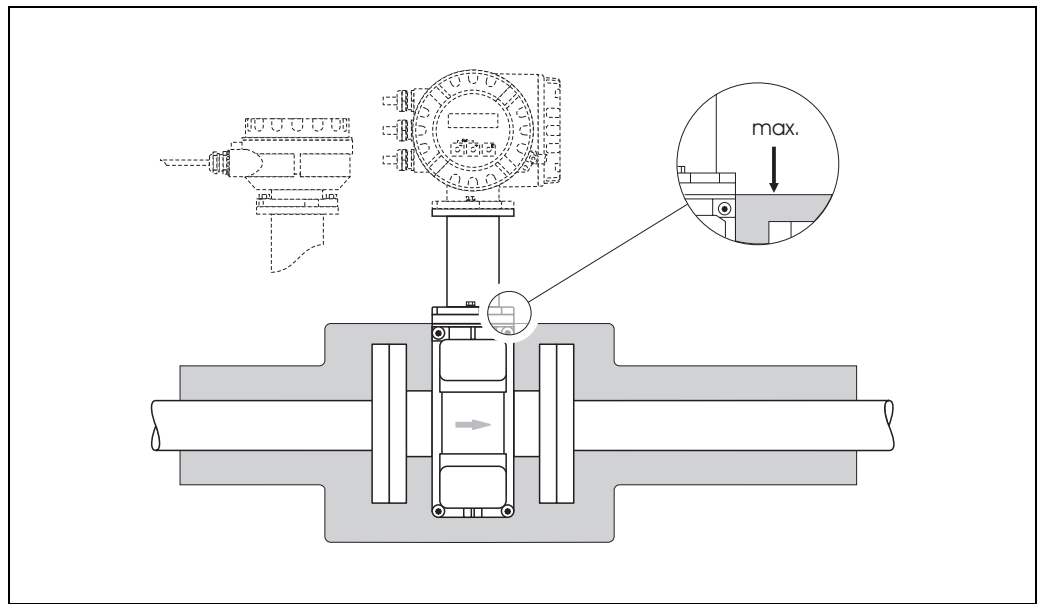

Fig. 19: Promag P sensor (high-temperature version): insulating the pipe

Screw tightening torques (Promag P)

Note the following points:

- The tightening torques listed below are for lubricated threads only.
- Always tighten the screws uniformly and in diagonally opposite sequence.
- Overtightening the screws will deform the sealing faces or damage the seals.
- The tightening torques listed below apply only to pipes not subjected to tensile stress.

Tightening torques for:

- EN (DIN) → [29](#)
- ANSI → [30](#)
- JIS → [30](#)
- AS 2129 → [31](#)
- AS 4087 → [31](#)

Promag P tightening torques for EN (DIN)

Nominal diameter [mm]	EN (DIN) Pressure rating [bar]	Screws	Max. tightening torque [Nm]	
			PTFE	PFA
15	PN 40	4 × M 12	11	–
25	PN 40	4 × M 12	26	20
32	PN 40	4 × M 16	41	35
40	PN 40	4 × M 16	52	47
50	PN 40	4 × M 16	65	59
65 *	PN 16	8 × M 16	43	40
65	PN 40	8 × M 16	43	40
80	PN 16	8 × M 16	53	48
80	PN 40	8 × M 16	53	48
100	PN 16	8 × M 16	57	51
100	PN 40	8 × M 20	78	70
125	PN 16	8 × M 16	75	67
125	PN 40	8 × M 24	111	99
150	PN 16	8 × M 20	99	85
150	PN 40	8 × M 24	136	120
200	PN 10	8 × M 20	141	101
200	PN 16	12 × M 20	94	67
200	PN 25	12 × M 24	138	105
250	PN 10	12 × M 20	110	–
250	PN 16	12 × M 24	131	–
250	PN 25	12 × M 27	200	–
300	PN 10	12 × M 20	125	–
300	PN 16	12 × M 24	179	–
300	PN 25	16 × M 27	204	–
350	PN 10	16 × M 20	188	–
350	PN 16	16 × M 24	254	–
350	PN 25	16 × M 30	380	–
400	PN 10	16 × M 24	260	–
400	PN 16	16 × M 27	330	–
400	PN 25	16 × M 33	488	–
450	PN 10	20 × M 24	235	–
450	PN 16	20 × M 27	300	–
450	PN 25	20 × M 33	385	–
500	PN 10	20 × M 24	265	–
500	PN 16	20 × M 30	448	–
500	PN 25	20 × M 33	533	–
600	PN 10	20 × M 27	345	–
600 *	PN 16	20 × M 33	658	–
600	PN 25	20 × M 36	731	–

* Designed acc. to EN 1092-1 (not to DIN 2501)

Promag P tightening torques for ANSI

Nominal diameter		ANSI Pressure rating [lbs]	Screws	Max. tightening torque			
[mm]	[inch]			PTFE		PFA	
				[Nm]	[lbf · ft]	[Nm]	[lbf · ft]
15	½"	Class 150	4 × ½"	6	4	–	–
15	½"	Class 300	4 × ½"	6	4	–	–
25	1"	Class 150	4 × ½"	11	8	10	7
25	1"	Class 300	4 × 5/8"	14	10	12	9
40	1 ½"	Class 150	4 × ½"	24	18	21	15
40	1 ½"	Class 300	4 × ¾"	34	25	31	23
50	2"	Class 150	4 × 5/8"	47	35	44	32
50	2"	Class 300	8 × 5/8"	23	17	22	16
80	3"	Class 150	4 × 5/8"	79	58	67	49
80	3"	Class 300	8 × ¾"	47	35	42	31
100	4"	Class 150	8 × 5/8"	56	41	50	37
100	4"	Class 300	8 × ¾"	67	49	59	44
150	6"	Class 150	8 × ¾"	106	78	86	63
150	6"	Class 300	12 × ¾"	73	54	67	49
200	8"	Class 150	8 × ¾"	143	105	109	80
250	10"	Class 150	12 × 7/8"	135	100	–	–
300	12"	Class 150	12 × 7/8"	178	131	–	–
350	14"	Class 150	12 × 1"	260	192	–	–
400	16"	Class 150	16 × 1"	246	181	–	–
450	18"	Class 150	16 × 1 1/8"	371	274	–	–
500	20"	Class 150	20 × 1 1/8"	341	252	–	–
600	24"	Class 150	20 × 1 ¼"	477	352	–	–

Promag P tightening torques for JIS

Nominal diameter [mm]	JIS Pressure rating	Screws	Max. tightening torque [Nm]	
			PTFE	PFA
15	10K	4 × M 12	16	–
15	20K	4 × M 12	16	–
25	10K	4 × M 16	32	27
25	20K	4 × M 16	32	27
32	10K	4 × M 16	38	–
32	20K	4 × M 16	38	–
40	10K	4 × M 16	41	37
40	20K	4 × M 16	41	37
50	10K	4 × M 16	54	46
50	20K	8 × M 16	27	23
65	10K	4 × M 16	74	63
65	20K	8 × M 16	37	31
80	10K	8 × M 16	38	32
80	20K	8 × M 20	57	46
100	10K	8 × M 16	47	38
100	20K	8 × M 20	75	58
125	10K	8 × M 20	80	66
125	20K	8 × M 22	121	103

Nominal diameter [mm]	JIS Pressure rating	Screws	Max. tightening torque [Nm]	
			PTFE	PFA
150	10K	8 × M 20	99	81
150	20K	12 × M 22	108	72
200	10K	12 × M 20	82	54
200	20K	12 × M 22	121	88
250	10K	12 × M 22	133	–
250	20K	12 × M 24	212	–
300	10K	16 × M 22	99	–
300	20K	16 × M 24	183	–

Promag P tightening torques for AS 2129

Nominal diameter [mm]	AS 2129 Pressure rating	Screws	Max. tightening torque [Nm] PTFE
25	Table E	4 × M 12	21
50	Table E	4 × M 16	42

Promag P tightening torques for AS 4087

Nominal diameter [mm]	AS 4087 Pressure rating	Screws	Max. tightening torque [Nm] PTFE
50	PN 16	4 × M 16	42

3.3.3 Installing the Promag H sensor

The sensor is supplied, as per your order, with or without installed process connections. Installed process connections are screwed onto the sensor using 4 or 6 hexagonal-headed bolts.



Caution!

Depending on the application and the length of the pipe, the sensor must be supported or more securely mounted if necessary. Particularly when using process connections made of plastic, it is essential that the sensor be mounted securely. A wall mounting kit for this purpose can be ordered separately as an accessory from Endress+Hauser (→ 89).

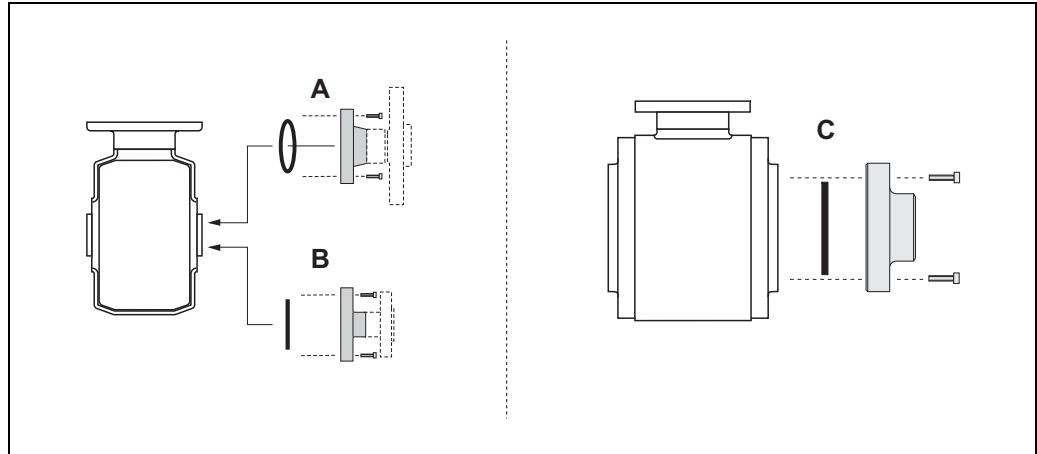

Fig. 20: Promag H process connections; DN 2 to 25 / DN 40 to 100 (1/12" to 1" / 1 1/2" to 4")

A = DN 2 to 25 (1/12" to 1") / Process connections with O-ring

Weld nipple (DIN EN ISO 1127, ODT / SMS), flange (EN (DIN), ANSI, JIS), flange made of PVDF (EN (DIN), ANSI, JIS), external thread, internal thread, hose connection, PVC adhesive fitting

B = DN 2 to 25 (1/12" to 1") / Process connections with aseptic molded seal

Weld nipple (DIN 11850, ODT / SMS), clamp (ISO 2852, DIN 32676, L14 AM7), coupling (DIN 11851, DIN 11864-1, SMS 1145), flange DIN 11864-2

C = DN 40 to 100 (1 1/2" to 4") / Process connections with aseptic molded seal

Weld nipple (DIN 11850, ODT / SMS), clamp (ISO 2852, DIN 32676, L14 AM7), coupling (DIN 11851, DIN 11864-1, ISO 2853, SMS 1145), flange DIN 11864-2

Seals

When mounting the process connections, please ensure that the relevant seals are clean and properly centered.



Caution!

- In the case of metallic process connections, the screws must be fully tightened. The process connection forms a metallic connection with the sensor, which ensures a defined compression of the seal.
- In the case of process connections made of plastic, the maximum screw tightening torques for lubricated threads (7 Nm / 5.2 lbf ft) must be adhered to. In the case of plastic flanges, a seal must always be used between the connection and the counterflange.
- Depending on the application, the seals should be replaced periodically, particularly when molded seals (aseptic version) are used!

The interval between replacements depends on the frequency of the cleaning cycles and on the temperatures of the fluid and the cleaning process. Replacement seals can be ordered as an accessory at a later stage → 89.

Using and installing grounding rings (DN 2 to 25, 1/12" to 1")

In case the process connections are made of plastic (e.g. flanges or adhesive fittings), the potential between the sensor and the fluid must be equalised using additional ground rings.

If the ground rings are not installed this can affect the accuracy of the measurements or cause the destruction of the sensor through the galvanic corrosion of the electrodes.



Caution!

- Depending on the option ordered, plastic rings may be installed at the process connections instead of ground rings. These plastic rings serve only as spacers and have no potential equalization function. In addition, they provide a sealing function at the interface between the sensor and process connection. For this reason, with process connections without ground rings, these plastic rings/seals must not be removed, or must always be installed.
- Ground rings can be ordered separately from Endress+Hauser as accessories → [89](#).
When placing the order, make certain that the ground ring is compatible with the material used for the electrodes. Otherwise, there is a risk that the electrodes may be destroyed by galvanic corrosion! Information about the materials can be found on → [123](#).
- Ground rings, including the seals, are mounted within the process connections. Therefore, the fitting length is not affected.

1. Loosen the four or six hexagonal headed bolts (1) and remove the process connection from the sensor (4).
2. Remove the plastic ring (3), including the two O-ring seals (2).
3. Place one seal (2) in the groove of the process connection.
4. Place the metal ground ring (3) on the process connection.
5. Now place the second seal (2) in the groove of the ground ring.
6. Finally, mount the process connection on the sensor again. With plastic process connections, note the max. torques for lubricated threads (7 Nm / 5.2 lbf ft).

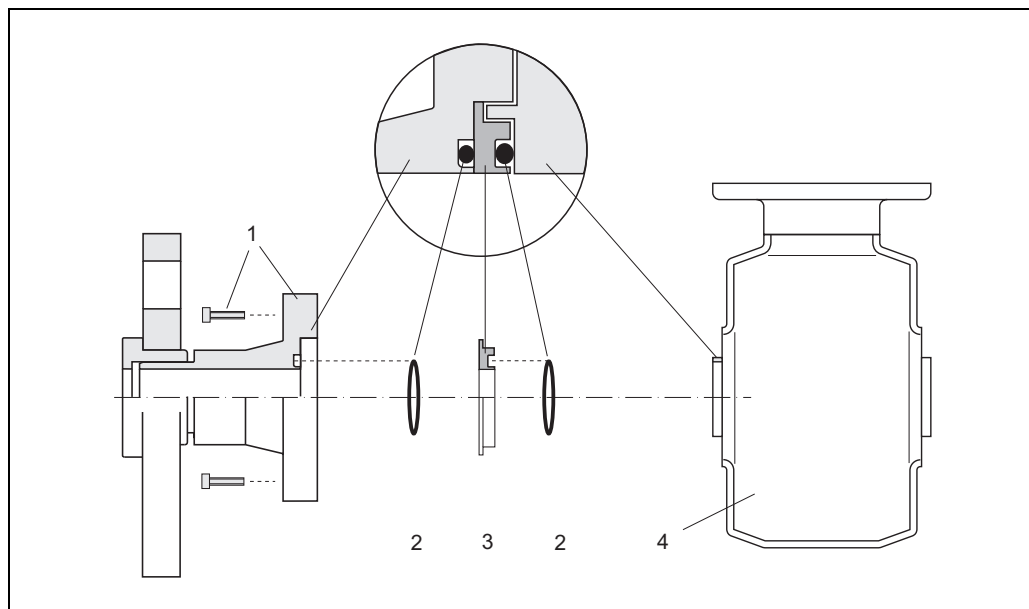

Fig. 21: Installing grounding rings in the Promag H (DN 2 to 25, 1/12" to 1")

- 1 = Hexagonal-headed bolts, process connection
 2 = O-ring seals
 3 = Grounding ring or plastic ring (spacer)
 4 = Sensor

Welding the transmitter into the pipe (weld nipple)



Caution!

Risk of electronics being destroyed. Please ensure that the welding system is *not* grounded via the sensor or transmitter.

1. Secure the sensor using several welding points in the piping. A welding jig suitable for this purpose can be ordered separately as an accessory →  89.
2. Loosen the screws at the process connection flange, and remove the sensor incl. seal from the piping.
3. Weld the process connection into the pipe.
4. Mount the sensor back into the pipe. When doing so, make sure that the seal is clean and positioned correctly.



Note!

- If the welding is done properly with thin-walled food pipes, the seal will not be damaged by heat even when mounted. Nonetheless, it is recommended that you dismantle the sensor and seal.
- For dismantling purposes, it must be possible to open the piping a total of approx. 8 mm.

Cleaning using pigs

When cleaning using pigs, please note the internal diameters of the measuring tube and the process connection. All the dimensions and lengths of the sensor and transmitter are provided in the separate documentation "Technical Information" →  128.

3.3.4 Turning the transmitter housing

Turning the aluminum field housing



Warning!

The rotating mechanism in devices with Ex d/de or FM/CSA Cl. I Div. 1 approval is different to that described here. The relevant procedure is described in the Ex-specific documentation.

1. Loosen the two securing screws.
2. Turn the bayonet catch as far as it will go.
3. Carefully lift the transmitter housing as far as it will go.
4. Turn the transmitter housing to the desired position (max. $2 \times 90^\circ$ in either direction).
5. Lower the housing into position and reengage the bayonet catch.
6. Retighten the two securing screws.

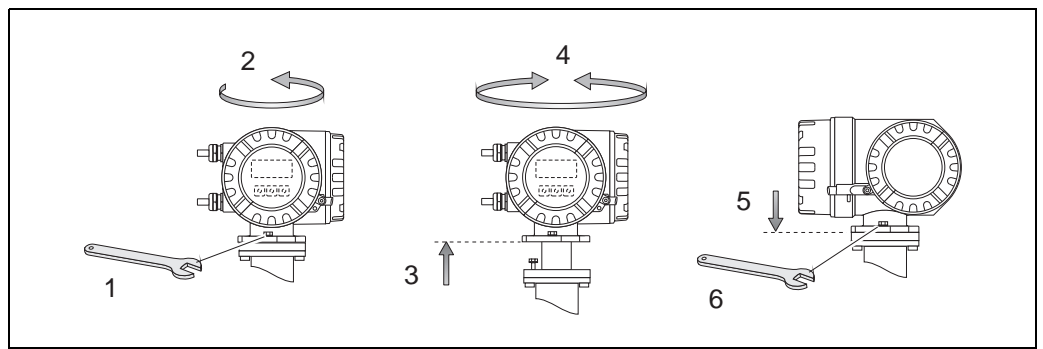

Fig. 22: Turning the transmitter housing (aluminum field housing)

Turning the stainless steel field housing

1. Loosen the two securing screws.
2. Carefully lift the transmitter housing as far as it will go.
3. Turn the transmitter housing to the desired position (max. $2 \times 90^\circ$ in either direction).
4. Lower the housing into position once more.
5. Retighten the two securing screws.

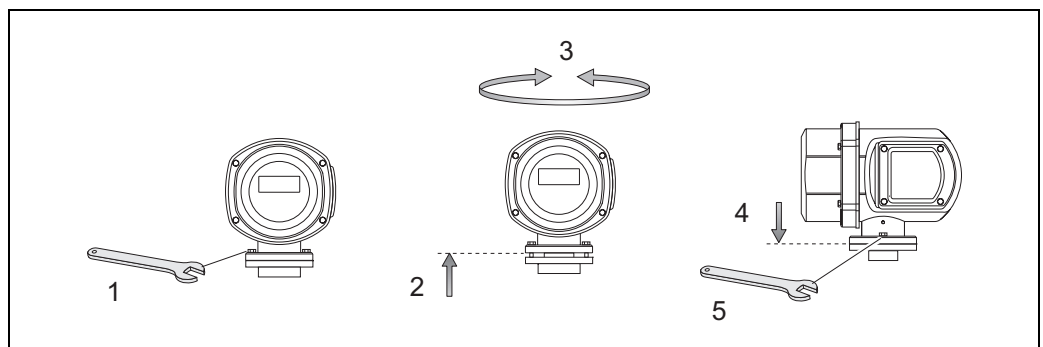

Fig. 23: Turning the transmitter housing (stainless steel field housing)

3.3.5 Turning the local display

1. Unscrew the electronics compartment cover from the transmitter housing.
2. Press the latches on the side of the display module and pull the module out of the electronics compartment cover.
3. Turn the display to the desired position (max. $4 \times 45^\circ$ in both directions) and position it back on the electronics compartment cover.
4. Screw the cover of the electronics compartment firmly onto the transmitter housing.

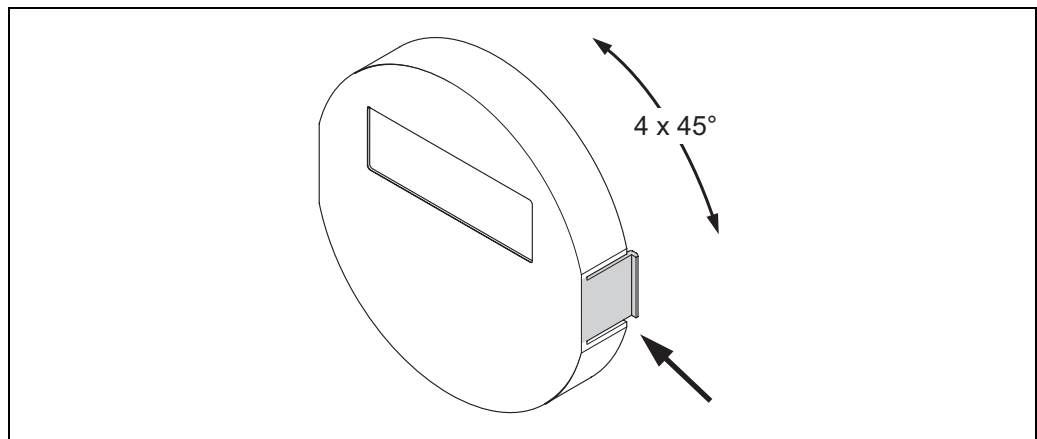

Fig. 24: Turning the local display (field housing)

3.3.6 Installing the wall-mount housing

There are various ways of installing the wall-mount housing:

- Mounted directly on the wall
- Panel mounting (with separate mounting kit, accessories) → 38
- Pipe mounting (with separate mounting kit, accessories) → 38



Caution!

- Make sure that the permitted ambient temperature range is observed (see nameplate or → 114). Install the device in a shady location. Avoid direct sunlight.
- Always install the wall-mount housing in such a way that the cable entries are pointing down.

Mounted directly on the wall

1. Drill the holes as illustrated.
2. Remove the cover of the connection compartment (a).
3. Push the two securing screws (b) through the appropriate bores (c) in the housing.
 - Securing screws (M6): max. \varnothing 6.5 mm (0.24")
 - Screw head: max. \varnothing 10.5 mm (0.4")
4. Secure the transmitter housing to the wall as indicated.
5. Screw the cover of the connection compartment (a) firmly onto the housing.

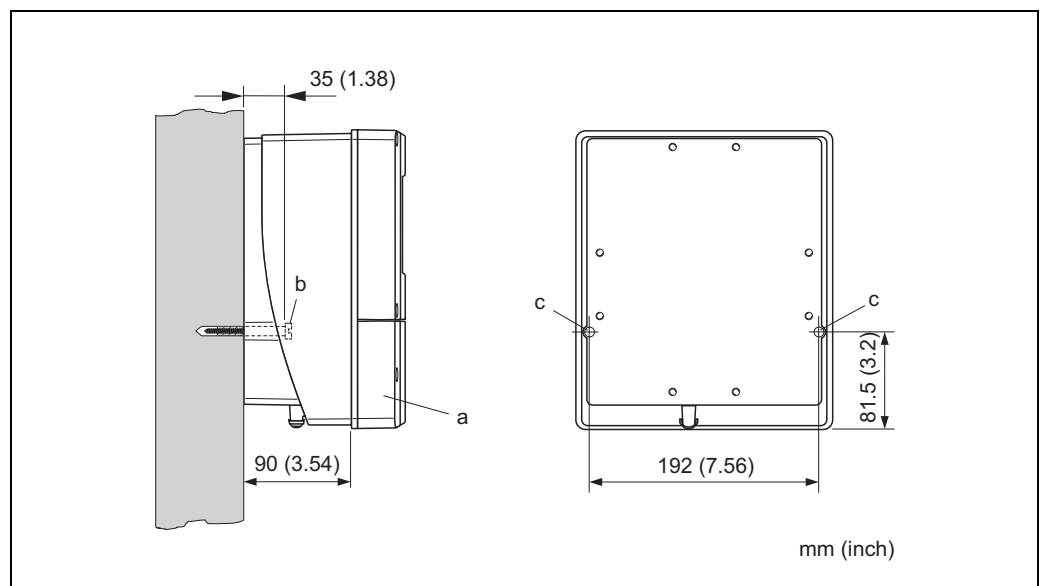

Fig. 25: Mounted directly on the wall

a0001130-ae

Panel mounting

1. Prepare the opening in the panel as illustrated.
2. Slide the housing into the opening in the panel from the front.
3. Screw the fasteners onto the wall-mount housing.
4. Place the threaded rods in the fasteners and screw them down until the housing is seated tightly against the panel wall. Afterwards, tighten the locking nuts. Additional support is not necessary.

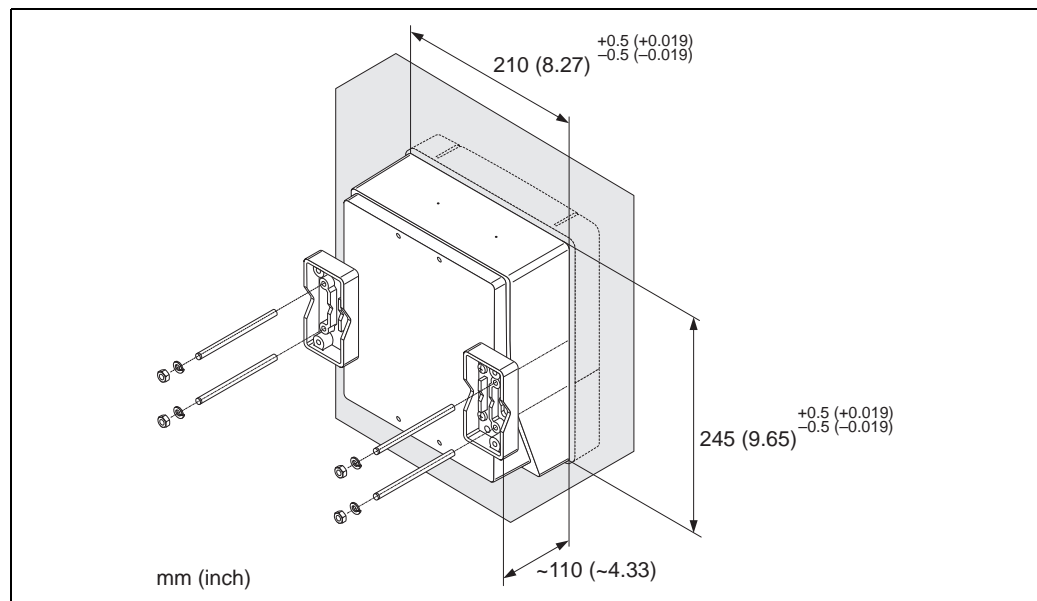

Fig. 26: Panel mounting (wall-mount housing)

Pipe mounting

The assembly should be performed by following the instructions in the following diagram.



Caution!

If the device is mounted to a warm pipe, make sure that the housing temperature does not exceed +60 °C (+140 °F), which is the maximum permissible temperature.

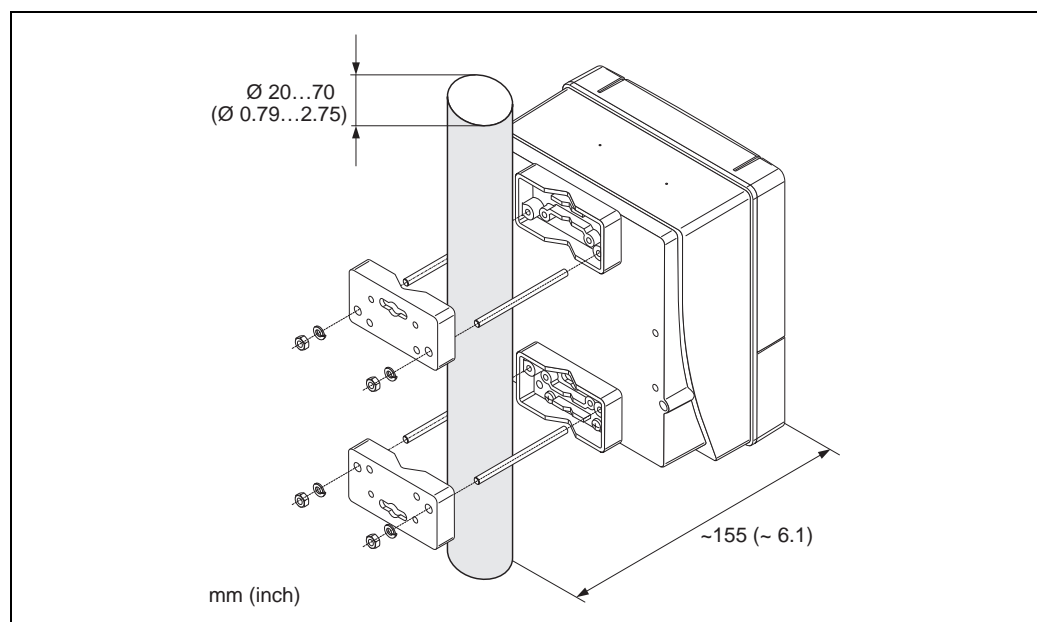

Fig. 27: Pipe mounting (wall-mount housing)

3.4 Post-installation check

Perform the following checks after installing the measuring device in the pipe:

Device condition/specifications	Notes
Is the device damaged (visual inspection)?	-
Does the device correspond to specifications at the measuring point, including process temperature and pressure, ambient temperature, minimum fluid conductivity, measuring range, etc.?	→ 111
Installation	Notes
Does the arrow on the sensor nameplate match the direction of flow through the pipe?	-
Is the position of the measuring electrode plane correct?	→ 15
Is the position of the empty pipe detection electrode correct?	→ 15
Were all screws tightened to the specified tightening torques when the sensor was installed?	→ 21
Were the correct seals installed (type, material, installation)?	→ 21
Are the measuring point number and labeling correct (visual inspection)?	-
Process environment / process conditions	Notes
Are the inlet and outlet runs respected?	Inlet run $\geq 5 \times DN$ Outlet run $\geq 2 \times DN$
Is the measuring device protected against moisture and direct sunlight?	-
Is the sensor adequately protected against vibration (attachment, support)?	Acceleration up to 2 g in accordance with IEC 600 68-2-6 → 114

4 Wiring



Warning!

When connecting Ex-certified devices, please take note of the instructions and wiring diagrams in the Ex-specific supplement to these Operating Instructions. Should you have any questions, please contact your Endress+Hauser sales office for assistance.



Note!

The device does not have an internal circuit breaker. An external switch or circuit breaker must therefore be installed which can be used to disconnect the device from the main power source.

4.1 Connecting the remote version

4.1.1 Connecting the sensor



Warning!

- Risk of electric shock! Switch off the power supply before opening the device. Do **not** install or wire the device while it is connected to the power supply. Failure to comply with this precaution can result in irreparable damage to the electronics.

- Risk of electric shock! Connect the protective conductor to the ground terminal on the housing before the power supply is applied.



Caution!

- Only sensors and transmitters with the same serial number can be connected to one another. Communication problems can occur if the devices are not connected in this way.

- Risk of damaging the coil driver. Always switch off the power supply before connecting or disconnecting the coil cable.

Procedure

1. Transmitter: Remove the cover from the connection compartment (a).
2. Sensor: Remove the cover from the connection housing (b).
3. Feed the signal cable (c) and the coil cable (d) through the appropriate cable entries.



Caution!

Route the connecting cables securely (see "Connecting cable length" → 20).

4. Terminate the signal and coil current cable as indicated in the table:
 Promag W, P → Refer to the table → 42
 Promag H → Refer to the "Cable termination" table → 43
5. Establish the wiring between the sensor and the transmitter.
 The electrical wiring diagram that applies to your device can be found:
 - In the corresponding graphic:
 → 28 (Promag W, P); → 29 (Promag H)
 - In the cover of the sensor and transmitter



Note!

The cable shields of the Promag H sensor are grounded by means of the strain relief terminals (see also the "Cable termination" table → 43)



Caution!

Insulate the shields of cables that are not connected to eliminate the risk of short-circuits with neighboring cable shields inside the connection housing.

6. Transmitter: Screw the cover on the connection compartment (a).
7. Sensor: Secure the cover on the connection housing (b).

Promag W, P

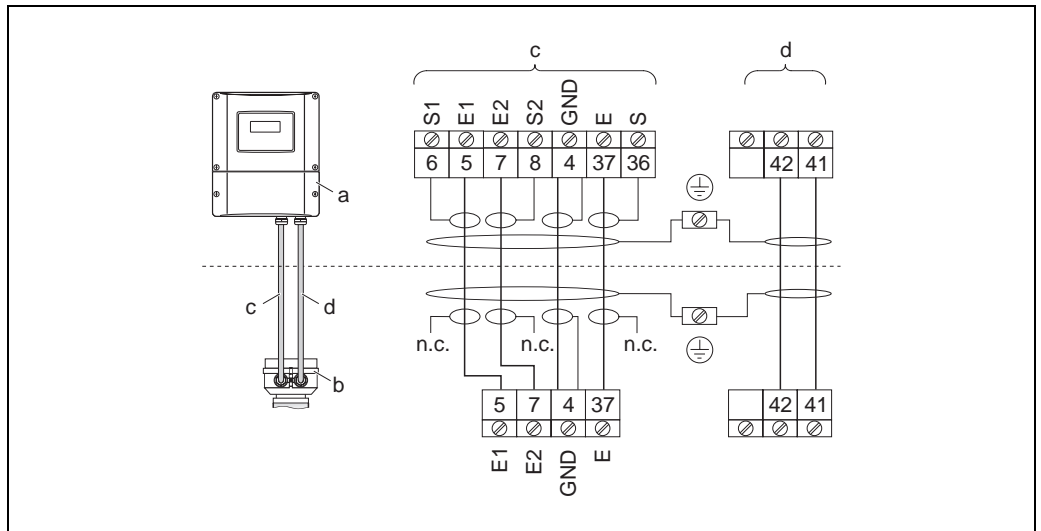

Fig. 28: Connecting the remote version of Promag W, P

- a Wall-mount housing connection compartment
- b Cover of the sensor connection housing
- c Signal cable
- d Coil current cable
- n.c. Not connected, insulated cable shields

Wire colors/Terminal No.:
 5/6 = brown, 7/8 = white, 4 = green, 37/36 = yellow

Promag H

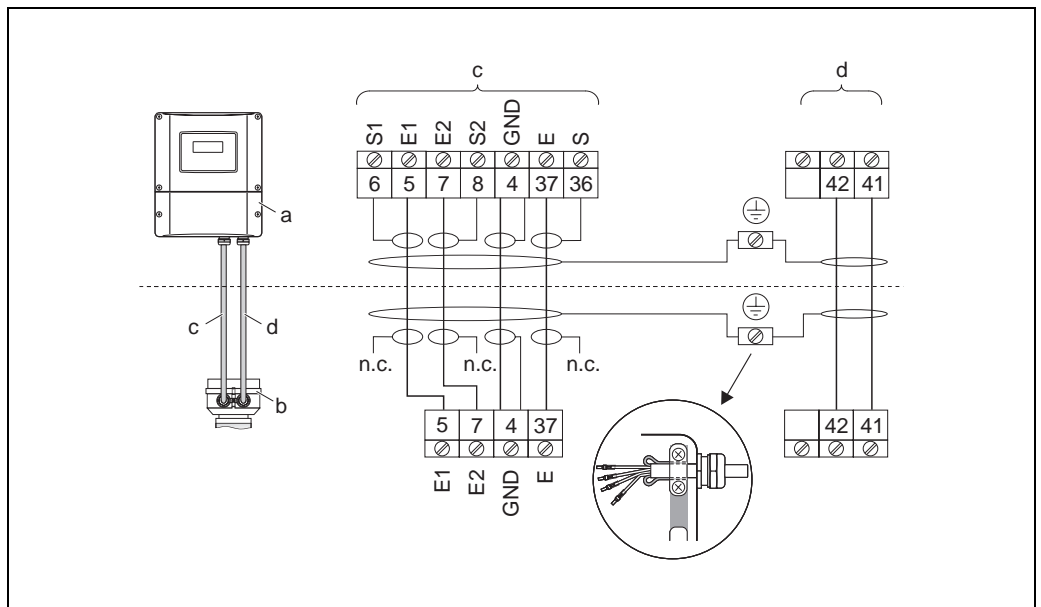

Fig. 29: Connecting the remote version of Promag H

- a Wall-mount housing connection compartment
- b Cover of the sensor connection housing
- c Signal cable
- d Coil current cable
- n.c. Not connected, insulated cable shields

Wire colors/Terminal No.:
 5/6 = brown, 7/8 = white, 4 = green, 37/36 = yellow

**Cable termination in remote version
Promag W/Promag P**

Terminate the signal and coil current cables as shown in the figure below (Detail A).
Fit the fine-wire cores with wire end ferrules (detail B: ① = red ferrules, Ø 1.0 mm; ② = white ferrules, Ø 0.5 mm)
* Stripping for reinforced cables only

Caution!

When fitting the connectors, pay attention to the following points:

- *Signal cable* → Make sure that the wire end ferrules do not touch the wire shields on the sensor side!
Minimum distance = 1 mm (exception "GND" = green cable)
- *Coil current cable* → Insulate one core of the three-core wire at the level of the core reinforcement; you only require two cores for the connection.

TRANSMITTER

Signal cable

Coil current cable

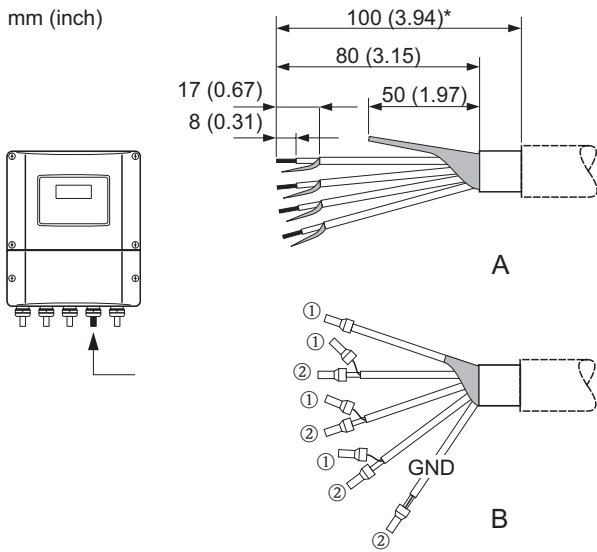

A0002687-ae

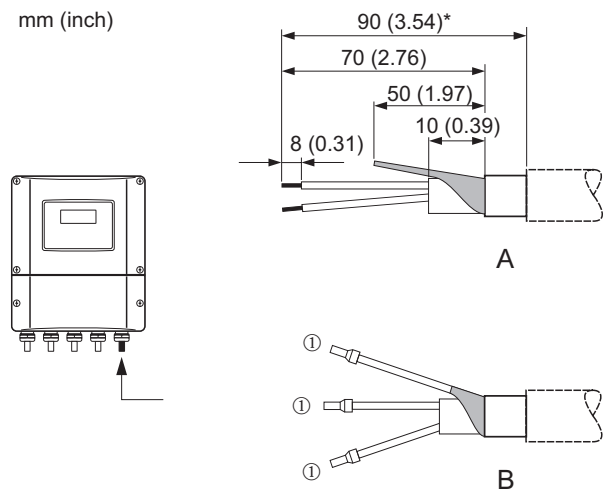

A0002688-ae

SENSOR

Signal cable

Coil current cable

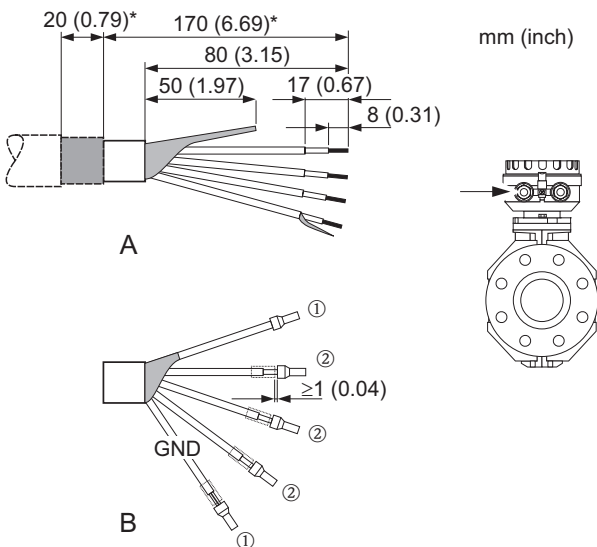

A0002646-AE

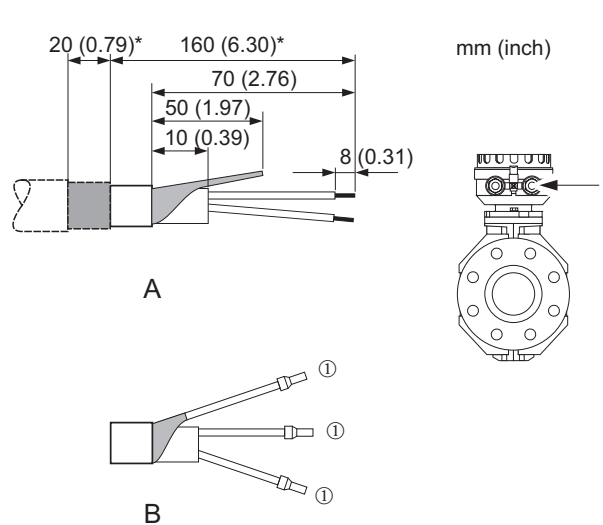

A0002650-ae

**Cable termination in remote version
Promag H**

Terminate the signal and coil current cables as shown in the figure below (Detail A).
Fit the fine-wire cores with wire end ferrules (detail B: ① = ferrules red, Ø 1.0 mm; ② = ferrule white, Ø 0.5 mm)

⚠ Caution!

When fitting the connectors, pay attention to the following points:

- *Signal cable* → Make sure that the wire end ferrules do not touch the wire shields on the sensor side!
Minimum distance = 1 mm (exception "GND" = green cable)
- *Coil current cable* → Insulate one core of the three-core wire at the level of the core reinforcement; you only require two cores for the connection.
- On the sensor side, reverse both cable shields approx. 15 mm over the outer jacket. The strain relief ensures an electrical connection with the connection housing.

TRANSMITTER

Signal cable

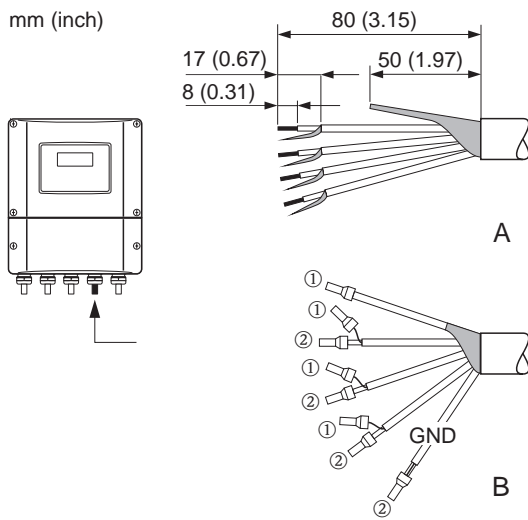

A0002686-ae

Coil current cable

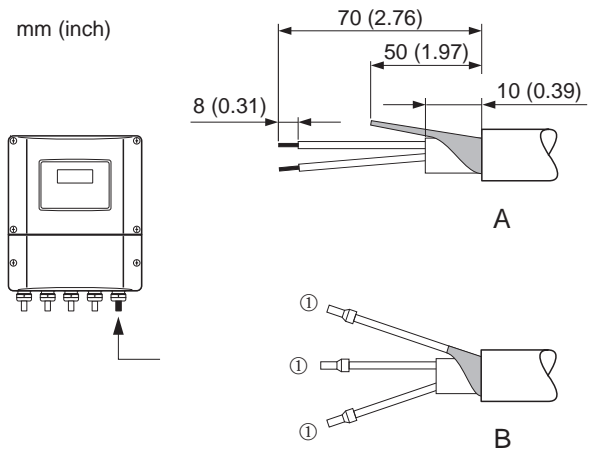

A0002684-ae

SENSOR

Signal cable

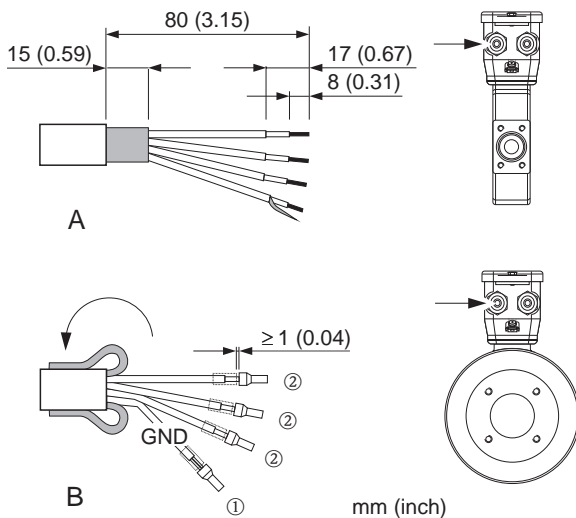

A0002647-ae

Coil current cable

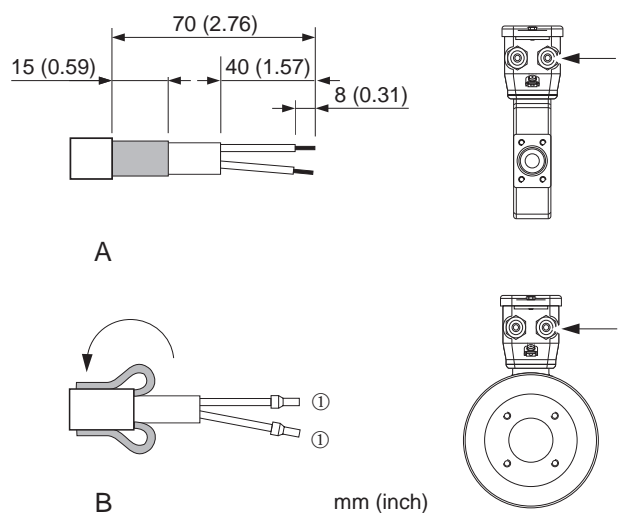

A0002648-ae

4.1.2 Cable specifications

Signal cable

- 3 × 0.38 mm² PVC cable with common, braided copper shield (Ø ~ 7 mm) and individually shielded cores
- With Empty Pipe Detection (EPD): 4 × 0.38 mm² PVC cable with common, braided copper shield (Ø ~ 7 mm) and individually shielded cores
- Conductor resistance: ≤ 50 Ω/km
- Capacitance: core/shield: ≤ 420 pF/m
- Operating temperature: -20 to +80 °C
- Conductor cross-section: max. 2.5 mm²

Coil cable

- 2 × 0.75 mm² PVC cable with common, braided copper shield (Ø ~ 7 mm)
- Conductor resistance: ≤ 37 Ω/km
- Capacitance: core/core, shield grounded: ≤ 120 pF/m
- Operating temperature: -20 to +80 °C
- Conductor cross-section: max. 2.5 mm²
- Test current for cable insulation: ≥1433 V AC rms 50/60 Hz or ≥2026 V DC

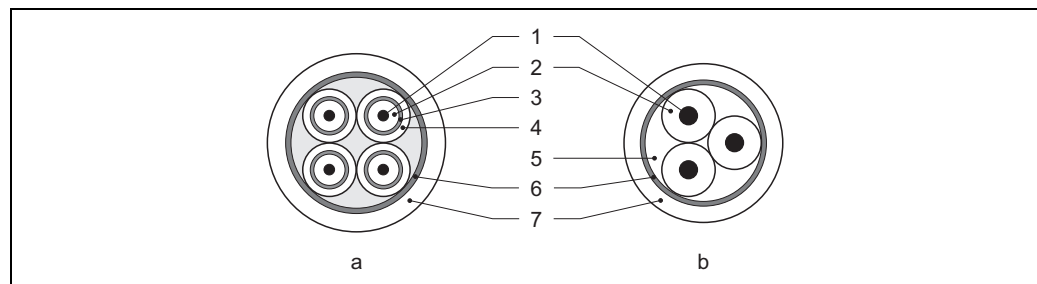

Fig. 30: Cable cross-section

- a Signal cable
b Coil current cable

1 = Core, 2 = Core insulation, 3 = Core shield, 4 = Core jacket, 5 = Core reinforcement, 6 = Cable shield, 7 = Outer jacket

Reinforced connecting cables

As an option, Endress+Hauser can also deliver reinforced connecting cables with an additional, reinforcing metal braid.

We recommend such cables for the following cases:

- Directly buried cable
- Cables endangered by rodents
- Device operation which should comply with the IP 68 (NEMA 6P) standard of protection

Operation in zones of severe electrical interference

The measuring device complies with the general safety requirements in accordance with EN 61010-1 and the EMC requirements of IEC/EN 61326.



Caution!

Grounding is by means of the ground terminals provided for the purpose inside the connection housing. Keep the stripped and twisted lengths of cable shield to the terminals as short as possible.

4.2 Connecting the measuring unit

4.2.1 Connecting the transmitter



Warning!

- Risk of electric shock! Switch off the power supply before opening the device. Do not install or wire the device while it is energized. Failure to comply with this precaution can result in irreparable damage to the electronics.
- Risk of electric shock! Connect the protective conductor to the ground terminal on the housing before the power supply is applied (not necessary if the power supply is galvanically isolated).
- Compare the specifications on the nameplate with the local voltage supply and frequency. Also comply with national regulations governing the installation of electrical equipment.

1. Remove the cover of the connection compartment (f) from the transmitter housing.
2. Feed the power supply cable (a) and the signal cable (b) through the appropriate cable entries.
3. Perform the wiring:
 - Wiring diagram (aluminum housing) → 31
 - Wiring diagram (stainless steel housing) → 32
 - Wiring diagram (wall-mount housing) → 33
 - Terminal assignment → 47
4. Screw the cover of the connection compartment (f) firmly onto the transmitter housing.

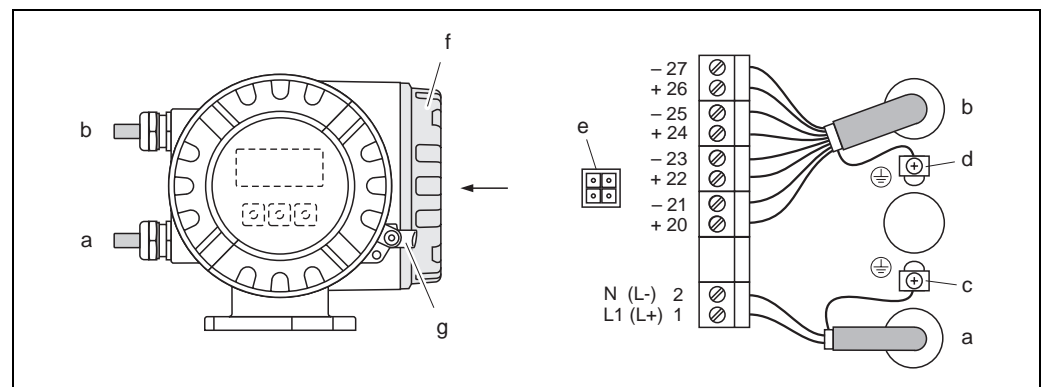
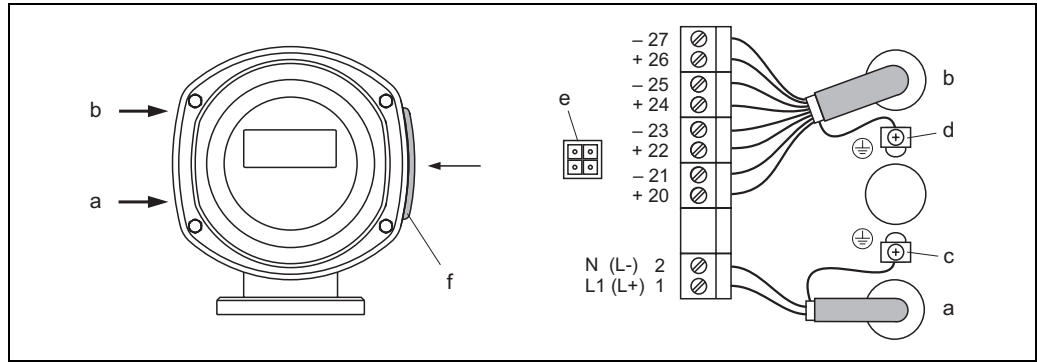

Fig. 31: Connecting the transmitter (aluminum field housing). Cable cross-section: max. 2.5 mm²

- a Cable for power supply: 85 to 260 V AC, 20 to 55 V AC, 16 to 62 V DC
Terminal **No. 1**: L1 for AC, L+ for DC
Terminal **No. 2**: N for AC, L- for DC
- b Signal cable: Terminals **Nos. 20–27** → 47
- c Ground terminal for protective ground
- d Ground terminal for signal cable shield
- e Service connector for connecting service interface FXA193 (Fieldcheck, FieldCare)
- f Cover of the connection compartment
- g Securing clamp



a0004584

Fig. 32: Connecting the transmitter (stainless steel field housing); cable cross-section: max. 2.5 mm²

- a Cable for power supply: 85 to 260 V AC, 20 to 55 V AC, 16 to 62 V DC
Terminal **No. 1**: L1 for AC, L+ for DC
Terminal **No. 2**: N for AC, L- for DC
- b Signal cable: Terminals **Nos. 20–27** → 47
- c Ground terminal for protective ground
- d Ground terminal for signal cable shield
- e Service connector for connecting service interface FXA193 (Fieldcheck, FieldCare)
- f Cover of the connection compartment

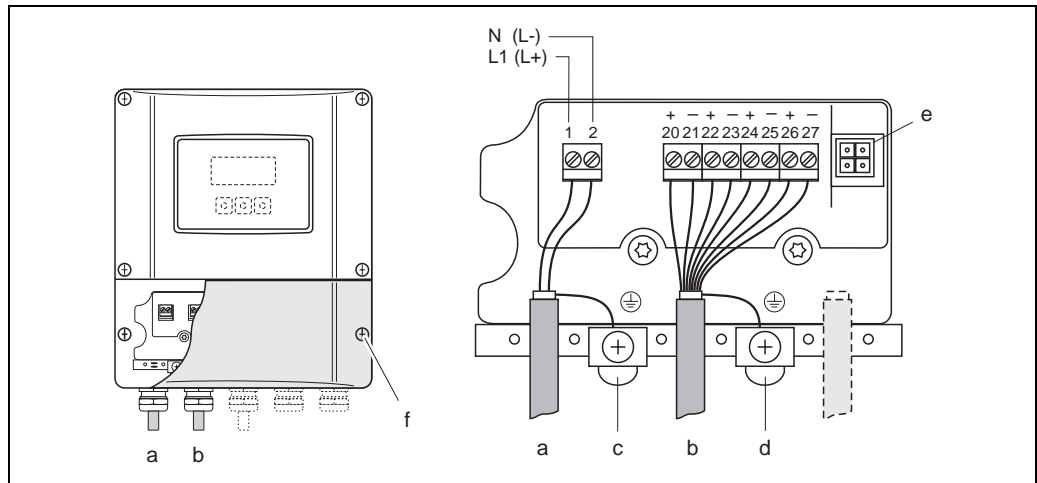

a0001135

Fig. 33: Connecting the transmitter (wall-mount housing); cable cross-section: max. 2.5 mm²

- a Cable for power supply: 85 to 260 V AC, 20 to 55 V AC, 16 to 62 V DC
Terminal **No. 1**: L1 for AC, L+ for DC
Terminal **No. 2**: N for AC, L- for DC
- b Signal cable: Terminals **Nos. 20–27** → 47
- c Ground terminal for protective ground
- d Ground terminal for signal cable shield
- e Service connector for connecting service interface FXA193 (Fieldcheck, FieldCare)
- f Cover of the connection compartment

4.2.2 Terminal assignment



Note!

The electrical characteristic quantities are listed in the "Technical data" section → [111](#).

Order variant	Terminal No. (inputs/outputs)			
	20 (+) / 21 (-)	22 (+) / 23 (-)	24 (+) / 25 (-)	26 (+) / 27 (-)
Fixed communication boards (fixed assignment)				
53***_*****A	–	–	Frequency output	Current output HART
53***_*****B	Relay output 2	Relay output 1	Frequency output	Current output HART
53***_*****S	–	–	Frequency output, Ex i	Current output, Ex i, active, HART
53***_*****T	–	–	Frequency output, Ex i	Current output, Ex i, passive, HART
Flexible communication boards				
53***_*****C	Relay output 2	Relay output 1	Frequency output	Current output HART
53***_*****D	Status input	Relay output	Frequency output	Current output HART
53***_*****L	Status input	Relay output 2	Relay output 1	Current output HART
53***_*****M	Status input	Frequency output	Frequency output	Current output HART
53***_*****2	Relay output	Current output	Frequency output	Current output HART
53***_*****4	Current input	Relay output	Frequency output	Current output HART
53***_*****5	Status input	Current input	Frequency output	Current output HART

Ground terminal → [45](#)

4.2.3 HART connection

Users have the following connection options at their disposal:

- Direct connection to transmitter by means of terminals 26(+) and 27 (-)
- Connection by means of the 4 to 20 mA circuit.



Hinweis!

- The measuring loop's minimum load must be at least 250 Ω .
- After commissioning, make the following settings:
 - CURRENT SPAN function → "4-20 mA HART" or "4-20 mA (25 mA) HART"
 - Switch HART write protection on or off → 71

Connection of the HART handheld communicator

See also the documentation issued by the HART Communication Foundation, and in particular HCF LIT 20: "HART, a technical summary".

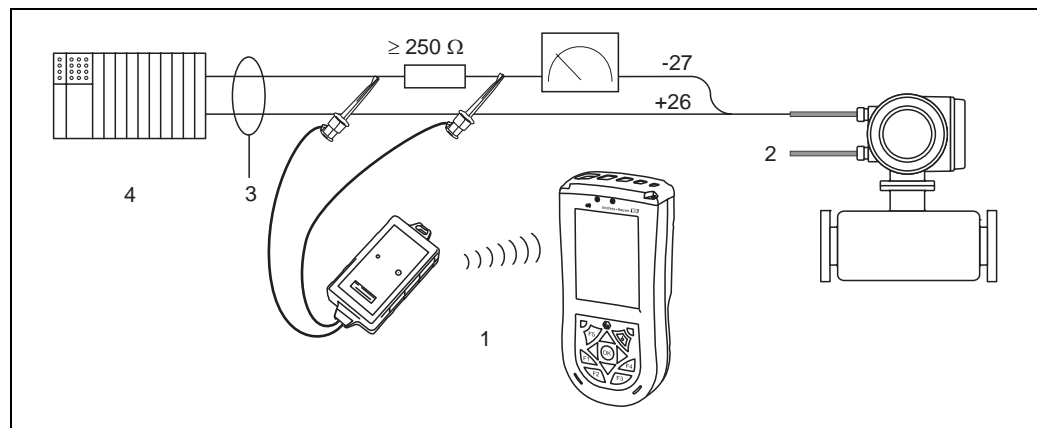

Fig. 34: Electrical connection of HART handheld Field Xpert SFX100

1 = HART handheld Field Xpert SFX100, 2 = Auxiliary energy, 3 = Shielding, 4 = Other devices or PLC with passive input

Connection of a PC with an operating software

In order to connect a PC with operating software (e.g. "FieldCare"), a HART modem (e.g. "Commubox FXA195") is needed.

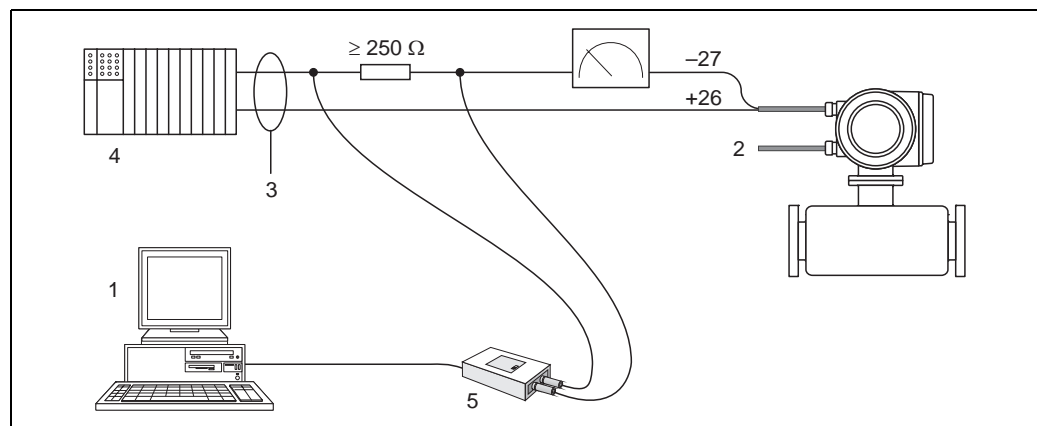

Fig. 35: Electrical connection of a PC with operating software

1 = PC with operating software, 2 = Auxiliary energy, 3 = Shielding, 4 = Other devices or PLC with passive input, 5 = HART modem, e.g. Commubox FXA195

4.3 Potential equalization



Warning!

The measuring system must be included in potential equalization.

Perfect measurement is only ensured when the medium and the sensor have the same electrical potential. Most Promag sensors have a reference electrode installed as standard, which guarantees the required potential equalization.

The following must also be taken into account for potential equalization:

- Company-internal grounding guidelines
- Operating conditions such as material/grounding of piping etc. (see table)

4.3.1 Potential equalization, Promag W, Promag P

Reference electrode available as standard

4.3.2 Potential equalization, Promag H

No reference electrode available!

There is always one electrical connection to the fluid via the metallic process connection.



Caution!

When using process connections made of plastic, potential equalization must be guaranteed through the use of grounding rings → 33.

The necessary grounding rings may be ordered separately as an accessory from Endress+Hauser (→ 89).

4.3.3 Connection examples for potential equalization

Standard case

Operating conditions	Potential equalization
<p>When using the measuring device in:</p> <ul style="list-style-type: none"> ■ metallic, grounded piping <p>Potential equalization is carried out via the ground terminal of the transmitter.</p> <p> Note! For installation in metal pipes, it is advisable to connect the ground terminal of the transmitter housing to the piping.</p>	<p style="text-align: right; font-size: small;">A0011892</p> <p><i>Fig. 36: Via the transmitter's ground terminal</i></p>

Special cases

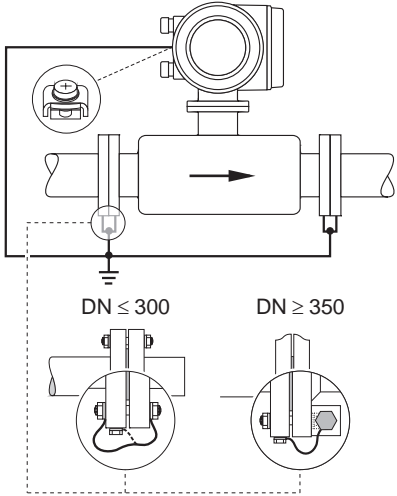
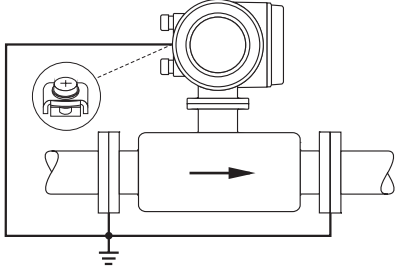
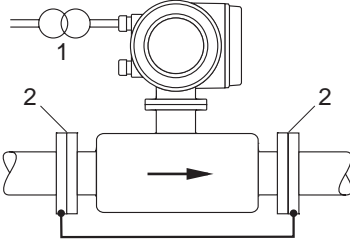
Operating conditions	Potential equalization
<p>When using the measuring device in:</p> <ul style="list-style-type: none"> ■ metallic, ungrounded piping <p>This type of connection occurs when:</p> <ul style="list-style-type: none"> ■ the usual potential equalization cannot be guaranteed ■ extremely high equalizing currents are expected <p>A ground cable (copper wire, at least 6 mm² (0.0093 in²)) is used to connect both sensor flanges to the respective pipe flange and ground them. Connect the transmitter or sensor connection housing, as applicable, to ground potential by means of the ground terminal provided for the purpose.</p> <p>The installation of the ground cable depends on the nominal diameter:</p> <ul style="list-style-type: none"> ■ DN ≤ 300 (12"): The ground cable is in direct connection with the conductive flange coating and is secured by the flange screws. ■ DN ≥ 350 (14"): The ground cable connects directly to the metal transport bracket. <p> Note! The ground cable for flange-to-flange connections can be ordered separately as an accessory from Endress+Hauser.</p>	 <p style="text-align: right;"><small>A0011893</small></p> <p><i>Fig. 37: Via the transmitter's ground terminal and the pipe flanges</i></p>
<p>When using the measuring device in:</p> <ul style="list-style-type: none"> ■ Plastic pipes ■ Isolating lined pipes <p>This type of connection occurs when:</p> <ul style="list-style-type: none"> ■ the usual potential equalization cannot be guaranteed ■ extremely high equalizing currents are expected <p>Potential equalization takes place using additional ground disks, which are connected to the ground terminal via a ground cable (copper wire, min. 6 mm² (0.0093 in²)). When installing the ground disks, please comply with the enclosed Installation Instructions.</p>	 <p style="text-align: right;"><small>A0011895</small></p> <p><i>Fig. 38: Via the transmitter's ground terminal and the optionally available ground disks</i></p>
<p>When using the measuring device in:</p> <ul style="list-style-type: none"> ■ pipes with cathodic protection <p>The device is installed in the pipeline in such a way that it is potential-free.</p> <p>Using a ground cable (copper wire, min. 6 mm² (0.0093 in²)), only the two pipe flanges are connected. When doing so, the ground cable is mounted directly on the conductive flange coating using flange screws.</p> <p>Please note the following during installation:</p> <ul style="list-style-type: none"> ■ The relevant regulations for potential-free installations must be observed. ■ There must not be an electrically conductive connection between the piping and the device. ■ The mounting material must be able to withstand the relevant torques. 	 <p style="text-align: right;"><small>A0011896</small></p> <p><i>Fig. 39: Potential equalization and cathodic protection</i></p> <p>1 Isolation transformer power supply 2 Electrically isolated</p>

4.4 Degree of protection

The devices fulfill all the requirements for IP 67 (NEMA 4X).

Compliance with the following points is mandatory following installation in the field or servicing, in order to ensure that IP 67 protection (NEMA 4X) is maintained:

- The housing seals must be clean and undamaged when inserted into their grooves. The seals must be dried, cleaned or replaced if necessary.
- All housing screws and screw covers must be firmly tightened.
- The cables used for connection must be of the specified external diameter → 112.
- Tighten cable glands to prevent leakages.
- The cables must loop down before they enter the cable entries ("water trap"). This arrangement prevents moisture penetrating the entry. Always install the measuring device in such a way that the cable entries do not point up.
- Close off unused cable entries using suitable insert plugs.
- Do not remove the grommet from the cable entry.



Fig. 40: Installation instructions, cable entries



Caution!

Do not loosen the screws of the sensor housing as otherwise the degree of protection guaranteed by Endress+Hauser no longer applies.





Note!

The sensor can also be supplied with IP 68 rating (permanent immersion in water to a depth of 3 meters (10 ft)). In this case the transmitter must be installed remote from the sensor.

4.5 Post-connection check

Perform the following checks after completing electrical installation of the measuring device:

Device condition and specifications	Notes
Are cables or the device damaged (visual inspection)?	-
Electrical connection	Notes
Does the supply voltage match the specifications on the nameplate?	<ul style="list-style-type: none"> ■ 85 to 250 V AC (50 to 60 Hz) ■ 20 to 28 V AC (50 to 60 Hz) ■ 11 to 40 V DC
Do the cables used comply with the necessary specifications?	→  44
Do the cables have adequate strain relief?	-
Is the cable type route completely isolated? Without loops and crossovers?	-
Are the power-supply and signal cables correctly connected?	See the wiring diagram inside the cover of the connection compartment
Are all screw terminals firmly tightened?	-
Have the measures for grounding/potential equalization been correctly implemented?	→  49
Are all cable entries installed, firmly tightened and correctly sealed? Cables looped as "water traps"?	→  51
Are all housing covers installed and firmly tightened?	-

5 Operation

5.1 Display and operating elements

The local display enables you to read important parameters directly at the measuring point or to configure your device using the "Quick Setup" or the function matrix. The display consists of four lines; this is where measured values and/or status variables (direction of flow, empty pipe, bar graph, etc.) are displayed. You can change the assignment of display lines to variables at will in order to customize the display to suit your needs and preferences (→ see the "Description of Device Functions" manual).

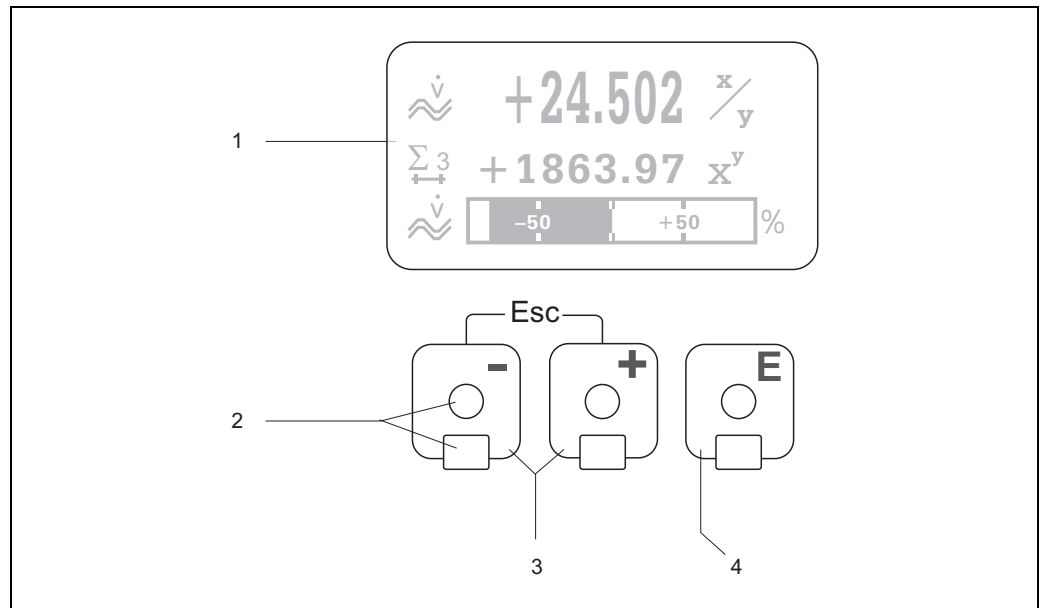

Fig. 41: Display and operating elements

- 1 **Liquid crystal display**
The backlit, four-line liquid crystal display shows measured values, dialog texts, fault messages and notice messages. The display as it appears when normal measuring is in progress is known as the HOME position (operating mode display).
- 2 **Optical sensors for Touch Control**
- 3 **□/□ keys**
 - HOME position → Direct access to totalizer values and actual values of inputs/outputs
 - Enter numerical values, select parameters
 - Select different blocks, groups and function groups within the function matrix

Press the □/□ keys **simultaneously** to trigger the following functions:

 - Exit the function matrix step by step → HOME position
 - Press and hold down the □/□ keys for longer than 3 seconds → Return directly to the HOME position
 - Cancel data entry
- 4 **⏎ key (Enter key)**
 - HOME position → Entry into the function matrix
 - Save the numerical values you input or settings you change

5.1.1 Display (operating mode)

The display area consists of three lines in all; this is where measured values are displayed, and/or status variables (direction of flow, bar graph, etc.). You can change the assignment of display lines to variables at will in order to customize the display to suit your needs and preferences (→ see the "Description of Device Functions" manual).

Multiplex mode:

A maximum of two different display variables can be assigned to each line. Variables multiplexed in this way alternate every 10 seconds on the display.

Error messages:

Display and presentation of system/process errors → 59

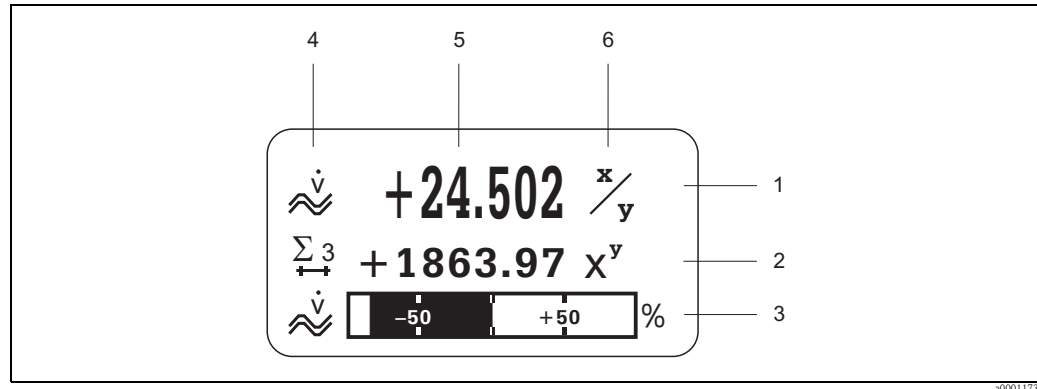

Fig. 42: Typical display for normal operating mode (HOME position)

- 1 Main line shows main measured values, e.g. flow
- 2 Supplementary line shows supplementary measured or status variables, e.g. totalizer reading.
- 3 Information line shows additional information on measured or status variables, e.g. bar graph representation of the full scale value attained by the flow rate
- 4 "Info icons" field shows additional information in the form of icons on the measured values displayed. A complete overview of all icons and their meaning can be found on → 55
- 5 "Measured values" field shows the current measured values
- 6 "Engineering unit" field shows the engineering units and time units defined for the current measured values.

5.1.2 Additional display functions

Depending on the order option (F-CHIP → 86), the local display has different display functions.

Device without batching software

From HOME position, use the \square \square keys to open an "Info Menu" containing the following information:

- Totalizer (including overflow)
- Actual values or states of the configured inputs/outputs
- Device TAG number (user-definable)

\square \square → Scan of individual values within the Info Menu



















\square (Esc key) → Back to HOME position

Device with batching software

On measuring instruments with installed batching software (F-Chip → 86) and a suitably configured display line, you can carry out filling processes directly using the local display. You will find a detailed description on → 54.

Icons

The icons which appear in the field on the left make it easier to read and recognize measured variables, device status, and error messages.

Icon	Meaning	Icon	Meaning
S	System error	P	Process error
	Fault message (with effect on outputs)	!	Notice message (without effect on outputs)
I 1 to n	Current output 1 to n or current input	P 1 to n	Pulse output 1 to n
F 1 to n	Frequency output 1 to n	S 1 to n	Status/relay output 1 to n or status input
Σ 1 to n	Totalizer 1 to n		
 a0001181	Measuring mode: PULSATING FLOW	 a0001182	Measuring mode: SYMMETRY (bidirectional)
 a0001183	Measuring mode: STANDARD	 a0001184	Counting mode totalizer: BALANCE (forward and reverse flow)
 a0001185	Counting mode totalizer: forward	 a0001186	Counting mode totalizer: reverse
 a0001187	Signal input (current or status input)		
 a0001188	Volume flow	 a0001195	Mass flow
 a0001200	Fluid density	 a0001207	Fluid temperature
 a0001201	Batching quantity upwards	 a0001202	Batching quantity downwards
 a0001203	Batching quantity	 a0001204	Batch sum
 a0001205	Batch counter (x times)	 a0001206	Remote configuration Active device operation via: HART, e.g. FieldCare, Field Xpert

5.1.3 Controlling the batching processes using the local display

Filling processes can be controlled directly by means of the local display with the aid of the optional "(Batching)" software package (F-CHIP, accessories → 89). Therefore, the device can be fully deployed in the field as a "batch controller".

Procedure:

1. Configure all the required batching functions and assign the lower display info line (= BATCHING KEYS) using the "Batch" Quick Setup menu (→ 78) or using the function matrix (→ 57).

The following "softkeys" then appear on the bottom line of the local display → 43:

- START = left display key (□)
- PRESET = middle display key (+)
- MATRIX = right display key (E)

2. Press the "PRESET (+)" key. Various batching process functions requiring configuration will now appear on the display:

"PRESET" → Initial settings for the batching process		
No.	Function	Configuration
7200	BATCH SELECTOR	□ → Select the batching liquid (BATCH #1 to 6)
7203	BATCH QUANTITY	If the "ACCESS CUSTOMER" option was selected for the "PRESET batch quantity" prompt in the "Batching" Quick Setup, the batching quantity can be altered via the local display. If the "LOCKED" option was selected, the batching quantity can only be read and cannot be altered until the private code has been entered.
7265	RESET TOTAL BATCH SUM/COUNTER	Resets the batching quantity counter or the total batching quantity to "0".

3. After exiting the PRESET menu, you can now start the batching process by pressing "START (□)". New softkeys (STOP / HOLD or GO ON) now appear on the display. You can use these to interrupt, continue or stop the batching process at any time. → 56

STOP (□) → Stops batching process

HOLD (+) → Interrupts batching process (softkey changes to "GO ON")

GO ON (+) → Continues batching process (softkey changes to "HOLD")

After the batch quantity is reached, the "START" or "PRESET" softkeys reappear on the display.

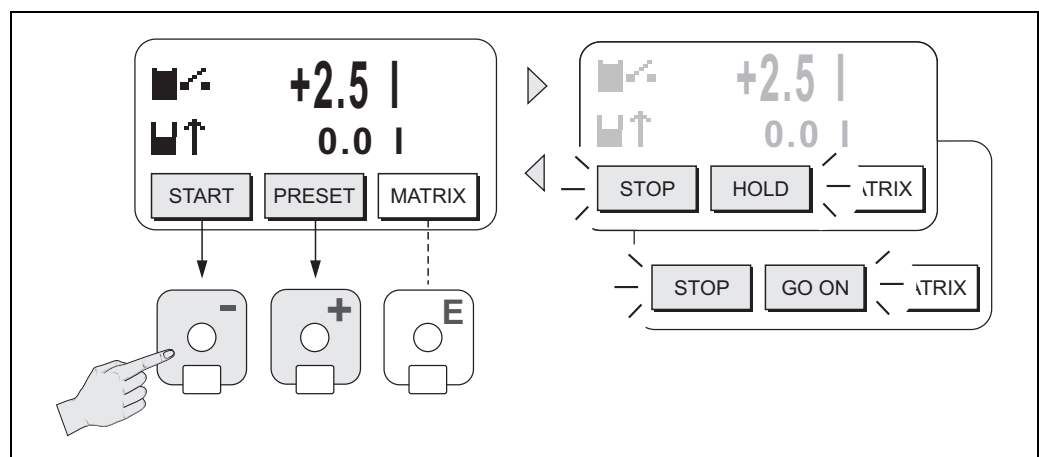

Fig. 43: Controlling batching processes using the local display (softkeys)

5.2 Brief Operating Instructions for the function matrix



Note!

- See the general notes → 58
 - Function descriptions → See the "Description of Device Functions" manual
1. HOME position → **E** → Enter the function matrix
 2. **+ / -** → Select a block (e.g. MEASURED VARIABLES) → **E**
 3. **+ / -** → Select a group (e.g. SYSTEM UNITS) → **E**
 4. **+ / -** → Select a function group (e.g. CONFIGURATION) → **E**
 5. Select a function (e.g. UNIT VOLUME FLOW) and change parameters/enter numerical values:
 - + / -** → Select or enter release code, parameters, numerical values
 - E** → Save entries
 6. Exit the function matrix:
 - Press and hold down Esc key (**Esc**) for longer than 3 seconds → HOME position
 - Repeatedly press Esc key (**Esc**) → Return step by step to HOME position

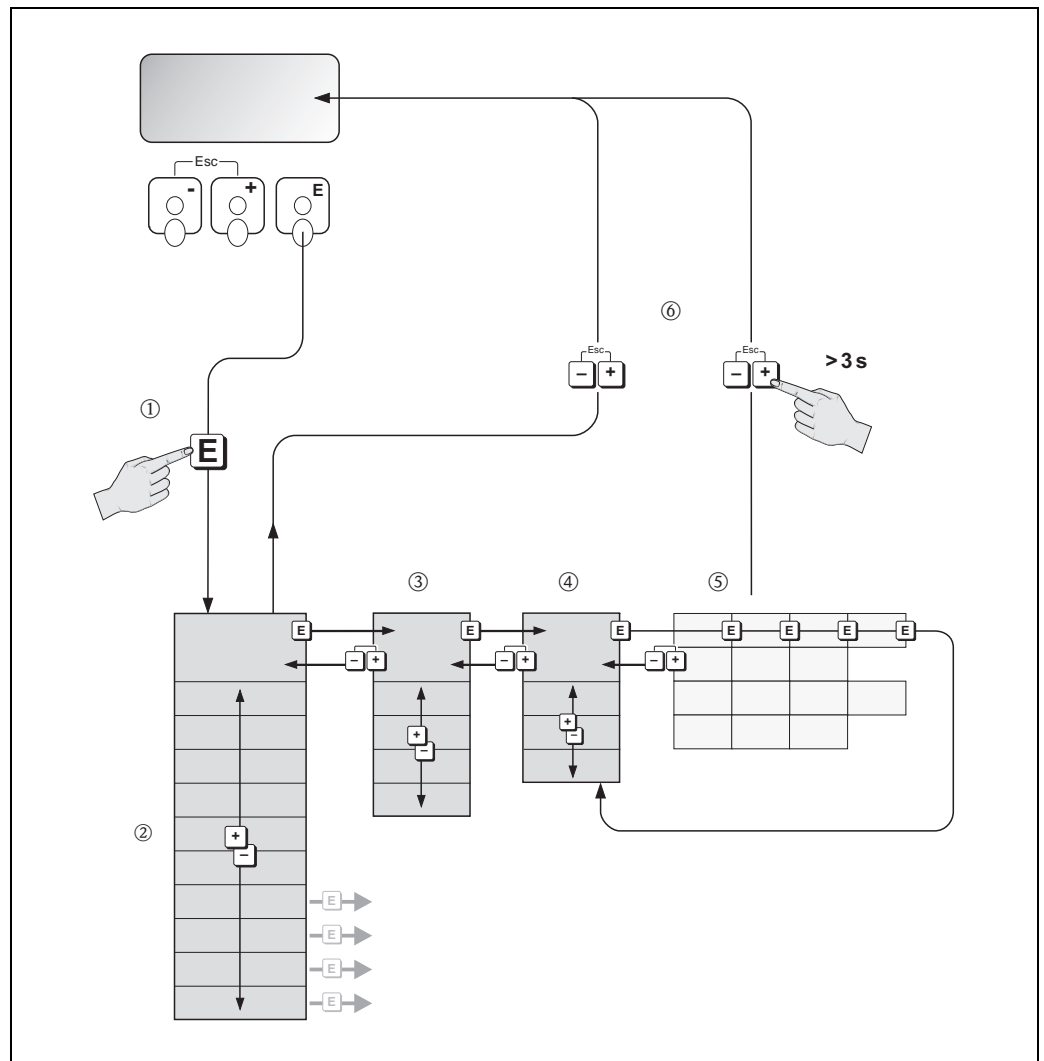





Fig. 44: Selecting functions and configuring parameters (function matrix)

5.2.1 General notes

The Quick Setup menu is adequate for commissioning with the necessary standard settings. Complex measuring operations on the other hand necessitate additional functions that you can configure as necessary and customize to suit your process parameters. The function matrix, therefore, comprises a multiplicity of additional functions which, for the sake of clarity, are arranged on a number of menu levels (blocks, groups, and function groups).

Comply with the following instructions when configuring functions:

- You select functions as described →  57.
 - Each cell in the function matrix is identified by a numerical or letter code on the display.
- You can switch off certain functions (OFF). If you do so, related functions in other function groups will no longer be displayed.
- Certain functions prompt you to confirm your data entries. Press / to select "SURE [YES]" and press  again to confirm. This saves your setting or starts a function, as applicable.
- Return to the HOME position is automatic if no key is pressed for 5 minutes.
- Programming mode is automatically disabled if you do not press a key within 60 seconds following automatic return to the HOME position.



Caution!

All functions are described in detail, including the function matrix itself, in the "Description of Device Functions" manual, which is a separate part of these Operating Instructions.



Note!



- The transmitter continues to measure while data entry is in progress, i.e. the current measured values are output via the signal outputs in the normal way.
- If the power supply fails, all preset and parameterized values remain safely stored in the EEPROM.

5.2.2 Enabling the programming mode

The function matrix can be disabled. Disabling the function matrix rules out the possibility of inadvertent changes to device functions, numerical values or factory settings. A numerical code (factory setting = 53) has to be entered before settings can be changed.

If you use a code number of your choice, you exclude the possibility of unauthorized persons accessing data (→ "Description of Device Functions" manual).

Comply with the following instructions when entering codes:

- If programming is disabled and the / keys are pressed in any function, a prompt for the code automatically appears on the display.
- If "0" is entered as the customer's code, programming is always enabled.
- The Endress+Hauser service organization can be of assistance if you mislay your personal code.



Caution!

Changing certain parameters such as all sensor characteristics, for example, influences numerous functions of the entire measuring system, particularly measuring accuracy. There is no need to change these parameters under normal circumstances and consequently, they are protected by a special code known only to the Endress+Hauser service organization. Please contact Endress+Hauser first if you have any questions.

5.2.3 Disabling the programming mode

Programming mode is disabled if you do not press a key within 60 seconds following automatic return to the HOME position.

You can also disable programming in the ACCESS CODE function by entering any number (other than the customer's code).

5.3 Error messages

5.3.1 Type of error

Errors which occur during commissioning or measuring operation are displayed immediately. If two or more system or process errors occur, the error with the highest priority is the one shown on the display.

The measuring system distinguishes between two types of error:

- **System errors:** This group comprises all device errors, e.g. communication errors, hardware errors, etc. → [93](#)
- **Process error:** This group includes all application errors e.g. empty pipe, etc. → [96](#)

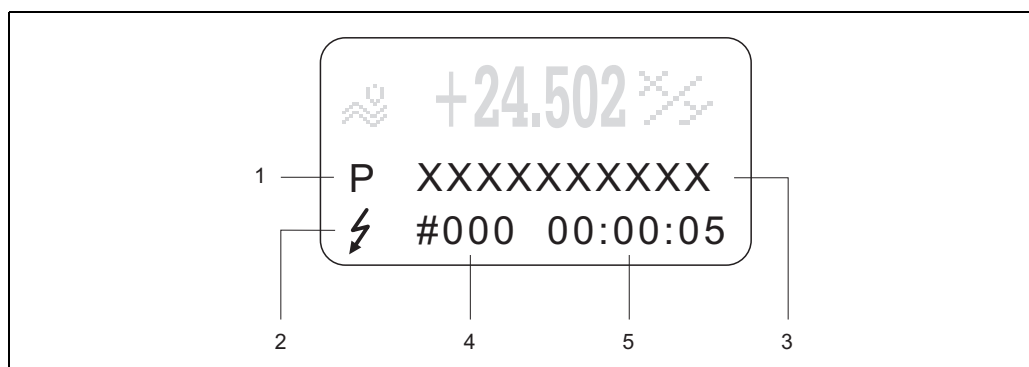

Fig. 45: Error messages on the display (example)

- 1 Error type: P = process error, S = system error
- 2 Error message type: ⚡ = fault message, != notice message
- 3 Error designation
- 4 Error number
- 5 Duration of most recent error occurrence (hours : minutes : seconds)

5.3.2 Error message type

Users have the option of weighting system and process errors differently, by defining them as **Fault messages** or **Notice messages**. You can define messages in this way with the aid of the function matrix (see the "Description of Device Functions" manual).

Serious system errors, e.g. module defects, are always identified and classed as "fault messages" by the measuring device.

Notice message (!)

- Displayed as → Exclamation mark (!), type of error (S: system error, P: process error)
- The error in question has no effect on the current measuring operation and the outputs of the measuring device.

Fault message (⚡)

- Displayed as → Lightning flash (⚡), type of error (S: system error, P: process error)
- The error in question interrupts or stops the current measuring operation and has an immediate effect on the outputs. The response of the outputs (failsafe mode) can be defined by means of functions in the function matrix. → [99](#)



Note!

- Error conditions can be output via the relay outputs.
- If an error message occurs, an upper or lower signal level for the breakdown information according to NAMUR 43 can be output via the current output.

5.3.3 Confirming error messages

For the sake of plant and process safety, the measuring device can be configured in such a way that fault messages displayed (f) always have to be rectified and acknowledged locally by pressing . Only then do the error messages disappear from the display. This option can be switched on or off by means of the "ACKNOWLEDGE FAULT MESSAGES" function (see the "Description of Device Functions" manual).



Note!

- Fault messages (f) can also be reset and confirmed via the status input.
- Notice messages (!) do not require acknowledgment. Note, however, that they remain visible until the cause of the error has been rectified.

5.4 Communication

In addition to local operation, the measuring device can be configured and measured values can be obtained by means of the HART protocol. Digital communication takes place using the 4–20 mA current output HART →  48.

The HART protocol allows the transfer of measuring and device data between the HART master and the field devices for configuration and diagnostics purposes. The HART master, e.g. a handheld terminal or PC-based operating programs (such as FieldCare), require device description (DD) files which are used to access all the information in a HART device. Information is exclusively transferred using so-called "commands". There are three different command groups:

There are three different command groups:

- *Universal commands*

All HART device support and use universal commands. The following functionalities, for example, are linked to them:

- Identify HART devices
- Reading digital measured values (volume flow, totalizer, etc.)

- *Common practice commands:*

Common practice commands offer functions which are supported and can be executed by most but not all field devices.

- *Device-specific commands:*

These commands allow access to device-specific functions which are not HART standard. Amongst other things, such commands access individual field device information, such as empty-pipe/full-pipe calibration values, low flow cutoff settings, etc.



Note!

The device has access to all three command classes.

List of all "universal commands" and "common practice commands" →  63

5.4.1 Operating options

For the complete operation of the measuring device, including device-specific commands, there are DD files available to the user to provide the following operating aids and programs:



Note!

- In the CURRENT SPAN function (current output 1), the HART protocol demands the setting "4-20 mA HART" or "4-20 mA (25 mA) HART".
- HART write protection can be enabled or disabled by means of a jumper on the I/O board
→ 71

Field Xpert HART Communicator

Selecting device functions with a HART Communicator is a process involving a number of menu levels and a special HART function matrix.

The HART manual in the carrying case of the HART Communicator contains more detailed information on the device.

Operating program "FieldCare"

Fieldcare is Endress+Hauser's FDT-based plant Asset Management Tool and allows the configuration and diagnosis of intelligent field devices. By using status information, you also have a simple but effective tool for monitoring devices. The Proline flow measuring devices are accessed via a service interface or via the service interface FXA193.

Operating program "SIMATIC PDM" (Siemens)

SIMATIC PDM is a standardized, manufacturer-independent tool for the operation, configuration, maintenance and diagnosis of intelligent field devices.

Operating program "AMS" (Emerson Process Management)

AMS (Asset Management Solutions): program for operating and configuring devices

5.4.2 Current device description files

The following table illustrates the suitable device description file for the operating tool in question and then indicates where these can be obtained.

HART protocol:

Valid for software	2.02.XX	→ "Device software" function (8100)
Device data HART		
Manufacturer ID:	11 _{hex} (ENDRESS+HAUSER)	→ "Manufact ID" function (6040)
Device ID:	42 _{hex}	→ "Device ID" function (6041)
HART version data	Device Revision 6/ DD Revision 1	
Software release	06.2009	
Operating	Sources for obtaining device descriptions	
Handheld terminal Field Xpert SFX100	Use update function of handheld terminal	
FieldCare / DTM	<ul style="list-style-type: none"> ■ www.endress.com → Download ■ CD-ROM (Endress+Hauser order number 56004088) ■ DVD (Endress+Hauser order number 70100690) 	
AMS	www.endress.com → Download	
SIMATIC PDM	www.endress.com → Download	

Tester/simulator	Sources for obtaining device descriptions
Fieldcheck	Update via FieldCare using the Flow Device FXA193/291 DTM in the Fieldflash module

5.4.3 Device and process variables

Device variables:

The following device variables are available using the HART protocol:

Code (decimal)	Device variable
0	OFF (not assigned)
1	Volume flow
2	Mass flow
52	Batch upwards
53	Batch downwards
250	Totalizer 1
251	Totalizer 2
252	Totalizer 3

Process variables:

At the factory, the process variables are assigned to the following device variables:



- Primary process variable (PV) → Volume flow
- Second process variable (SV) → Totalizer 1
- Third process variable (TV) → Mass flow
- Fourth process variable (FV) → not assigned













Note!





You can set or change the assignment of device variables to process variables using Command 51 → 66

5.4.4 Universal/Common practice HART commands

Command No. HART command / Access type		Command data (numeric data in decimal form)	Response data (numeric data in decimal form)
Universal Commands			
0	Read unique device identifier Access type = read	none	<p>Device identification delivers information on the device and the manufacturer. It cannot be changed.</p> <p>The response consists of a 12 byte device ID:</p> <ul style="list-style-type: none"> – Byte 0: fixed value 254 – Byte 1: Manufacturer ID, 17 = E+H – Byte 2: Device type ID, e.g. 66 = Promag 53 – Byte 3: Number of preambles – Byte 4: Universal commands rev. no. – Byte 5: Device-specific rev. no. Commands – Byte 6: Software revision – Byte 7: Hardware revision – Byte 8: Additional device information – Bytes 9-11: Device identification
1	Read primary process variable Access type = read	none	<ul style="list-style-type: none"> – Byte 0: HART unit code of the primary process variable – Bytes 1-4: Primary process variable <p><i>Factory setting:</i> Primary process variable = Volume flow</p> <p> Note!</p> <ul style="list-style-type: none"> ■ You can set or change the assignment of device variables to process variables using Command 51. ■ Manufacturer-specific units are represented using the HART unit code "240".
2	Read the primary process variable as current in mA and percentage of the set measuring range Access type = read	none	<ul style="list-style-type: none"> – Bytes 0-3: actual current of the primary process variable in mA – Bytes 4-7: Percentage of the set measuring range <p><i>Factory setting:</i> Primary process variable = Volume flow</p> <p> Note! You can set the assignment of device variables to process variables using Command 51.</p>
3	Read the primary process variable as current in mA and four (preset using Command 51) dynamic process variables Access type = read	none	<p>24 bytes are sent as a response:</p> <ul style="list-style-type: none"> – Bytes 0-3: primary process variable current in mA – Byte 4: HART unit code of the primary process variable – Bytes 5-8: Primary process variable – Byte 9: HART unit code of the second process variable – Bytes 10-13: Second process variable – Byte 14: HART unit code of the third process variable – Bytes 15-18: Third process variable – Byte 19: HART unit code of the fourth process variable – Bytes 20-23: Fourth process variable <p><i>Factory setting:</i></p> <ul style="list-style-type: none"> ■ Primary process variable = Volume flow ■ Second process variable = Totalizer 1 ■ Third process variable = Mass flow ■ Fourth process variable = OFF (not assigned) <p> Note!</p> <ul style="list-style-type: none"> ■ You can set the assignment of device variables to process variables using Command 51. ■ Manufacturer-specific units are represented using the HART unit code "240".

Command No. HART command / Access type		Command data (numeric data in decimal form)	Response data (numeric data in decimal form)
6	Set HART shortform address Access type = write	Byte 0: desired address (0 to 15) <i>Factory setting:</i> 0  Note! With an address >0 (multidrop mode), the current output of the primary process variable is set to 4 mA.	Byte 0: active address
11	Read unique device identification using the TAG (measuring point designation) Access type = read	Bytes 0-5: TAG	Device identification delivers information on the device and the manufacturer. It cannot be changed. The response consists of a 12 byte device ID if the given TAG agrees with the one saved in the device: – Byte 0: fixed value 254 – Byte 1: Manufacturer ID, 17 = E+H – Byte 2: Device type ID, 66 = Promag 53 – Byte 3: Number of preambles – Byte 4: Universal commands rev. no. – Byte 5: Device-specific rev. no. Commands – Byte 6: Software revision – Byte 7: Hardware revision – Byte 8: Additional device information – Bytes 9-11: Device identification
12	Read user message Access type = read	none	Bytes 0-24: User message  Note! You can write the user message using Command 17.
13	Read TAG, descriptor and date Access type = read	none	– Bytes 0-5: TAG – Bytes 6-17: descriptor – Bytes 18-20: Date  Note! You can write the TAG, descriptor and date using Command 18.
14	Read sensor information on primary process variable	none	– Bytes 0-2: Sensor serial number – Byte 3: HART unit code of sensor limits and measuring range of the primary process variable – Bytes 4-7: Upper sensor limit – Bytes 8-11: Lower sensor limit – Bytes 12-15: Minimum span  Note! ■ The data relate to the primary process variable (= volume flow). ■ Manufacturer-specific units are represented using the HART unit code "240".
15	Read output information of primary process variable Access type = read	none	– Byte 0: Alarm selection ID – Byte 1: Transfer function ID – Byte 2: HART unit code for the set measuring range of the primary process variable – Bytes 3-6: End of measuring range, value for 20 mA – Bytes 7-10: Start of measuring range, value for 4 mA – Bytes 11-14: Attenuation constant in [s] – Byte 15: Write protection ID – Byte 16: OEM dealer ID, 17 = E+H <i>Factory setting:</i> Primary process variable = Volume flow  Note! ■ You can set the assignment of device variables to process variables using Command 51. ■ Manufacturer-specific units are represented using the HART unit code "240".
16	Read the device production number Access type = read	none	Bytes 0-2: Production number

Command No. HART command / Access type		Command data (numeric data in decimal form)	Response data (numeric data in decimal form)
17	Write user message Access = write	You can save any 32-character long text in the device under this parameter: Bytes 0-23: Desired user message	Displays the current user message in the device: Bytes 0-23: Current user message in the device
18	Write TAG, descriptor and date Access = write	With this parameter, you can store an 8 character TAG, a 16 character descriptor and a date: – Bytes 0-5: TAG – Bytes 6-17: descriptor – Bytes 18-20: Date	Displays the current information in the device: – Bytes 0-5: TAG – Bytes 6-17: descriptor – Bytes 18-20: Date
Common Practice Commands			
34	Write damping value for primary process variable Access = write	Bytes 0-3: Damping value of the primary process variable in seconds <i>Factory setting:</i> Primary process variable = Volume flow	Displays the current damping value in the device: Bytes 0-3: Damping value in seconds
35	Write measuring range of primary process variable Access = write	Write the desired measuring range: – Byte 0: HART unit code of the primary process variable – Bytes 1-4: upper range, value for 20 mA – Bytes 5-8: lower range, value for 4 mA <i>Factory setting:</i> Primary process variable = Volume flow  Note! ■ You can set the assignment of device variables to process variables using Command 51. ■ If the HART unit code is not the correct one for the process variable, the device will continue with the last valid unit.	The currently set measuring range is displayed as a response: – Byte 0: HART unit code for the set measuring range of the primary process variable – Bytes 1-4: upper range, value for 20 mA – Bytes 5-8: lower range, value for 4 mA  Note! Manufacturer-specific units are represented using the HART unit code "240".
38	Device status reset (Configuration changed) Access = write	none	none
40	Simulate output current of primary process variable Access = write	Simulation of the desired output current of the primary process variable. An entry value of 0 exits the simulation mode: Bytes 0-3: Output current in mA <i>Factory setting:</i> Primary process variable = Volume flow  Note! You can set the assignment of device variables to process variables using Command 51.	The momentary output current of the primary process variable is displayed as a response: Bytes 0-3: Output current in mA
42	Perform master reset Access = write	none	none
44	Write unit of primary process variable Access = write	Set unit of primary process variable. Only unit which are suitable for the process variable are transferred to the device: Byte 0: HART unit code <i>Factory setting:</i> Primary process variable = Volume flow  Note! ■ If the written HART unit code is not the correct one for the process variable, the device will continue with the last valid unit. ■ If you change the unit of the primary process variable, this has no impact on the system units.	The current unit code of the primary process variable is displayed as a response: Byte 0: HART unit code  Note! Manufacturer-specific units are represented using the HART unit code "240".
48	Read additional device status Access = read	none	The device status is displayed in extended form as the response: Coding: see table →  67

Command No. HART command / Access type		Command data (numeric data in decimal form)	Response data (numeric data in decimal form)
50	Read assignment of the device variables to the four process variables Access = read	none	<p>Display of the current variable assignment of the process variables:</p> <ul style="list-style-type: none"> – Byte 0: Device variable code to the primary process variable – Byte 1: Device variable code to the second process variable – Byte 2: Device variable code to the third process variable – Byte 3: Device variable code to the fourth process variable <p><i>Factory setting:</i></p> <ul style="list-style-type: none"> ■ Primary process variable: Code 1 for volume flow ■ Second process variable: Code 250 for totalizer 1 ■ Third process variable: Code 2 for mass flow ■ Fourth process variable: Code 0 for OFF (not assigned) <p> Note! You can set the assignment of device variables to process variables using Command 51.</p>
51	Write assignments of the device variables to the four process variables Access = write	<p>Setting of the device variables to the four process variables:</p> <ul style="list-style-type: none"> – Byte 0: Device variable code to the primary process variable – Byte 1: Device variable code to the second process variable – Byte 2: Device variable code to the third process variable – Byte 3: Device variable code to the fourth process variable <p><i>Code of the supported device variables:</i> See information →  62</p> <p><i>Factory setting:</i></p> <ul style="list-style-type: none"> ■ Primary process variable = Volume flow ■ Second process variable = Totalizer 1 ■ Third process variable = Mass flow ■ Fourth process variable = OFF (not assigned) 	<p>The variable assignment of the process variables is displayed as a response:</p> <ul style="list-style-type: none"> – Byte 0: Device variable code to the primary process variable – Byte 1: Device variable code to the second process variable – Byte 2: Device variable code to the third process variable – Byte 3: Device variable code to the fourth process variable
53	Write device variable unit Access = write	<p>This command set the unit of the given device variables. Only those units which suit the device variable are transferred:</p> <ul style="list-style-type: none"> – Byte 0: Device variable code – Byte 1: HART unit code <p><i>Code of the supported device variables:</i> See information →  62</p> <p> Note!</p> <ul style="list-style-type: none"> ■ If the written unit is not the correct one for the device variable, the device will continue with the last valid unit. ■ If you change the unit of the device variable, this has no impact on the system units. 	<p>The current unit of the device variables is displayed in the device as a response:</p> <ul style="list-style-type: none"> – Byte 0: Device variable code – Byte 1: HART unit code <p> Note! Manufacturer-specific units are represented using the HART unit code "240".</p>
59	Write number of preambles in response message Access = write	<p>This parameter sets the number of preambles which are inserted in the response messages:</p> <p>Byte 0: Number of preambles (2 to 20)</p>	<p>As a response, the current number of the preambles is displayed in the response message:</p> <p>Byte 0: Number of preambles</p>

5.4.5 Device status/Error messages

You can read the extended device status, in this case, current error messages, via Command "48". The command delivers information which are partly coded in bits (see table below).





Note!

For a detailed explanation of the device status and error messages and their elimination, see → 92

Byte-Bit	Error No.	Short description of error → 92
0-0	001	Serious device error
0-1	011	Measuring amplifier has faulty EEPROM
0-2	012	Error when accessing data of the measuring amplifier EEPROM
0-3	not assigned	–
0-4	not assigned	–
0-5	not assigned	–
0-6	not assigned	–
0-7	not assigned	–
1-0	not assigned	–
1-1	031	S-DAT: defective or missing
1-2	032	S-DAT: Error accessing saved values
1-3	041	T-DAT: defective or missing
1-4	042	T-DAT: Error accessing saved values
1-5	051	I/O- board and the amplifier board are not compatible
1-6	not assigned	–
1-7	not assigned	–
2-0	not assigned	–
2-1	not assigned	–
2-2	not assigned	–
2-3	not assigned	–
2-4	not assigned	–
2-5	not assigned	–
2-6	not assigned	–
2-7	not assigned	–
3-0	not assigned	–
3-1	not assigned	–
3-2	not assigned	–
3-3	111	Totalizer checksum error
3-4	121	I/O board and the amplifier board are not compatible.
3-5	not assigned	–
3-6	205	T-DAT: Data download unsuccessful
3-7	206	T-DAT: Data upload unsuccessful
4-0	not assigned	–
4-1	not assigned	–
4-2	not assigned	–
4-3	251	Internal communication error on amplifier board
4-4	261	No data reception between amplifier and I/O board

Byte-Bit	Error No.	Short description of error →  92
4-5	not assigned	–
4-6	not assigned	–
4-7	not assigned	–
5-0	321	Coil current of the sensor is outside the tolerance.
5-1	not assigned	–
5-2	not assigned	–
5-3	not assigned	–
5-4	not assigned	–
5-5	not assigned	–
5-6	not assigned	–
5-7	339	Flow buffer: The temporarily buffered flow portions (measuring mode for pulsating flow) could not be cleared or output within 60 seconds.
6-0	340	
6-1	341	
6-2	342	Frequency buffer: The temporarily buffered flow portions (measuring mode for pulsating flow) could not be cleared or output within 60 seconds.
6-3	343	
6-4	344	
6-5	345	
6-6	346	Pulse buffer: The temporarily buffered flow portions (measuring mode for pulsating flow) could not be cleared or output within 60 seconds.
6-7	347	
7-0	348	
7-1	349	Current output: Actual flow value is out of range.
7-2	350	
7-3	351	
7-4	352	
7-5	353	Frequency output: Actual flow value is out of range.
7-6	354	
7-7	355	
8-0	356	Pulse output: The pulse output frequency is outside the permitted range.
8-1	357	
8-2	358	
8-3	359	
8-4	360	Pulse output: The pulse output frequency is outside the permitted range.
8-5	361	
8-6	362	
8-7	not assigned	–
9-0	not assigned	–
9-1	not assigned	–
9-2	not assigned	–
9-3	not assigned	–
9-4	not assigned	–
9-5	not assigned	–
9-6	not assigned	–
9-7	not assigned	–

Byte-Bit	Error No.	Short description of error →  92
10-0	not assigned	–
10-1	not assigned	–
10-2	not assigned	–
10-3	not assigned	–
10-4	not assigned	–
10-5	not assigned	–
10-6	not assigned	–
10-7	401	Measuring tube partially filled or empty
11-0	not assigned	–
11-1	not assigned	–
11-2	461	EPD adjustment not possible because the fluid's conductivity is either too low or too high.
11-3	not assigned	–
11-4	463	The EPD adjustment values for empty pipe and full pipe are identical and therefore incorrect.
11-5	not assigned	–
11-6	471	Max. permitted batching time has been exceeded.
11-7	472	Underbatching: the minimum quantity was not reached. Overbatching: the maximum permitted batching quantity was exceeded.
12-0	473	The predefined batch quantity point was exceeded. End of filling process approaching.
12-1	481	Actual relaxation time has exceeded the limit value.
12-2	482	Electrical potential of electrode 1 has exceeded the limit value.
12-3	483	Electrical potential of electrode 2 has exceeded the limit value.
12-4	not assigned	–
12-5	not assigned	–
12-6	not assigned	–
12-7	501	New amplifier software version is loaded. Currently no other commands are possible.
13-0	not assigned	–
13-1	not assigned	–
13-2	571	Batching process in progress (valves are open)
13-3	572	Batching process has been stopped (valves are closed)
13-4	not assigned	–
13-5	not assigned	–
13-6	not assigned	–
13-7	not assigned	–
14-0	not assigned	–
14-1	not assigned	–
14-2	not assigned	–
14-3	601	Positive zero return active
14-4	not assigned	–
14-5	not assigned	–
14-6	not assigned	–

Byte-Bit	Error No.	Short description of error →  92
14-7	611	Simulation current output active
15-0	612	
15-1	613	
15-2	614	
15-3	621	Simulation frequency output active
15-4	622	
15-5	623	
15-6	624	
15-7	631	Simulation pulse output active
16-0	632	
16-1	633	
16-2	634	
16-3	641	Simulation status output active
16-4	642	
16-5	643	
16-6	644	
16-7	651	Simulation relay output active
17-0	652	
17-1	653	
17-2	654	
17-3	661	Simulation current input active
17-3	not assigned	–
17-5	not assigned	–
17-6	not assigned	–
17-7	671	Simulation status input active
18-0	672	
18-1	673	
18-2	674	
18-3	691	Simulation of response to error (outputs) active
18-4	692	Simulation of volume flow is active
18-5	not assigned	–
18-6	not assigned	–
18-7	not assigned	–
22-4	061	F-CHIP is defective or not on I/O board
24-5	363	Current input: Actual current value is out of range.

5.4.6 Switching HART write protection on and off

A jumper on the I/O board provides the means of activating or deactivating HART write protection.



Warning!

Risk of electric shock. Exposed components carry dangerous voltages. Make sure that the power supply is switched off before you remove the cover of the electronics compartment.

1. Switch off power supply.
2. Remove the I/O board → 102
3. Switch HART write protection on or off, as applicable, by means of the jumper (→ 46).
4. Installation of the I/O board is the reverse of the removal procedure.

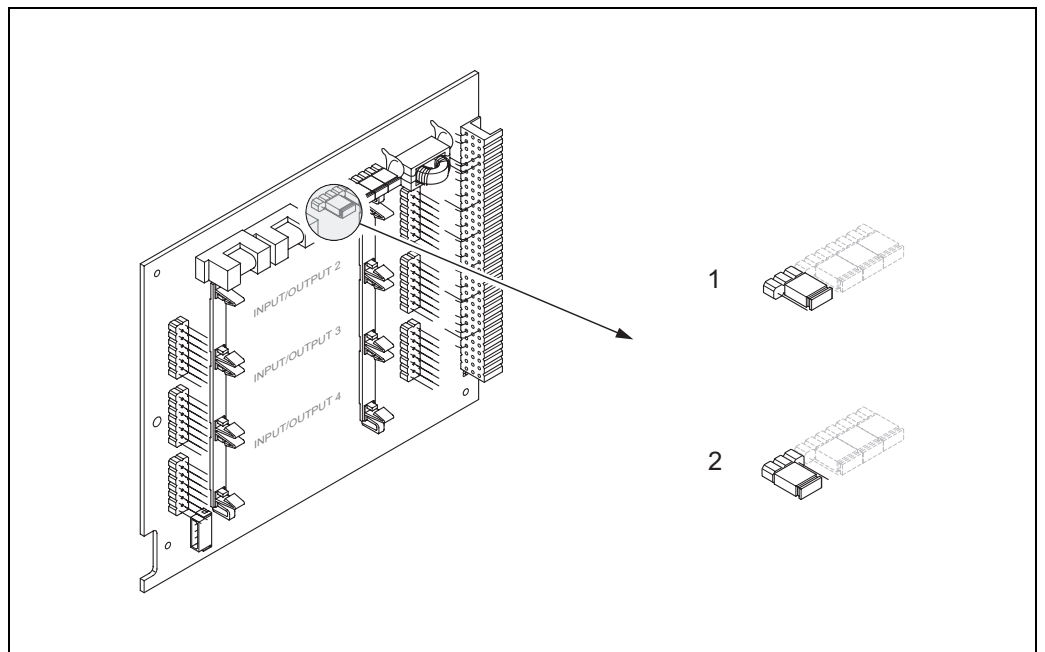

Fig. 46: Switching HART write protection on and off

- 1 Write protection OFF (default), i.e. HART protocol unlocked
- 2 Write protection ON, i.e. HART protocol locked

6 Commissioning

6.1 Function check

Make sure that all final checks have been completed before you start up your measuring point:

- Checklist for "Post-installation check" →  39
- Checklist for "Post-connection check" →  52

6.2 Switching on the measuring device

Once the connection checks have been successfully completed, it is time to switch on the power supply. The device is now operational.

The measuring device performs a number of post switch-on self-tests. As this procedure progresses the following sequence of messages appears on the local display:

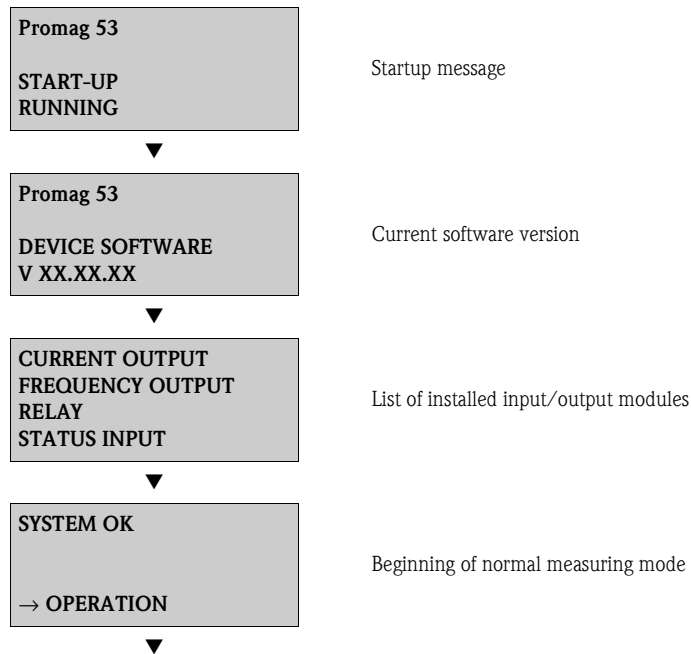

Normal measuring mode commences as soon as startup completes. Various measured value and/or status variables appear on the display (HOME position).





Note!

If startup fails, an error message indicating the cause is displayed.

6.3 Quick Setup

In the case of measuring devices without a local display, the individual parameters and functions must be configured by means of a configuration program, such as FieldCare from Endress+Hauser. If the measuring device is equipped with a local display, all the important device parameters for standard operation can be configured quickly and easily by means of the following Quick Setup menus. Additional functions can be configured too.

- "Commissioning" Quick Setup menu →  73
- "Pulsating flow" Quick Setup menu →  75
- "Batching" Quick Setup menu →  75

6.3.1 "Commissioning" Quick Setup menu



Note!

- The display returns to the cell SETUP COMMISSIONING (1002) if you press the ESC key combination during parameter interrogation. The stored parameters remain valid.
 - The "Commissioning" Quick Setup must be carried out before any of the other Quick Setups described in this Operating Instructions are run.
- ① The DELIVERY SETTINGS option sets each selected unit to the factory setting. The ACT.SETTING option accepts the units previously set by you.
 - ② Only units not yet configured in the current setup are offered for selection in each cycle. The unit for mass and volume is derived from the corresponding flow unit.
 - ③ The "YES" option remains visible until all the units have been configured. "NO" is the only option displayed when no further units are available.
 - ④ Only the outputs not yet configured in the current setup are offered for selection in each cycle.
 - ⑤ The "YES" option remains visible until all the outputs have been parameterized. "NO" is the only option displayed when no further outputs are available.
 - ⑥ The "automatic parameterization of the display" option contains the following basic settings/factory settings

YES	Main line = volume flow
	Additional line = totalizer 1
	Information line = operating/system conditions
NO	The existing (selected) settings remain.
 - ⑦ The Quick Setup "Batching" is only available when the optional software package BATCHING is installed.

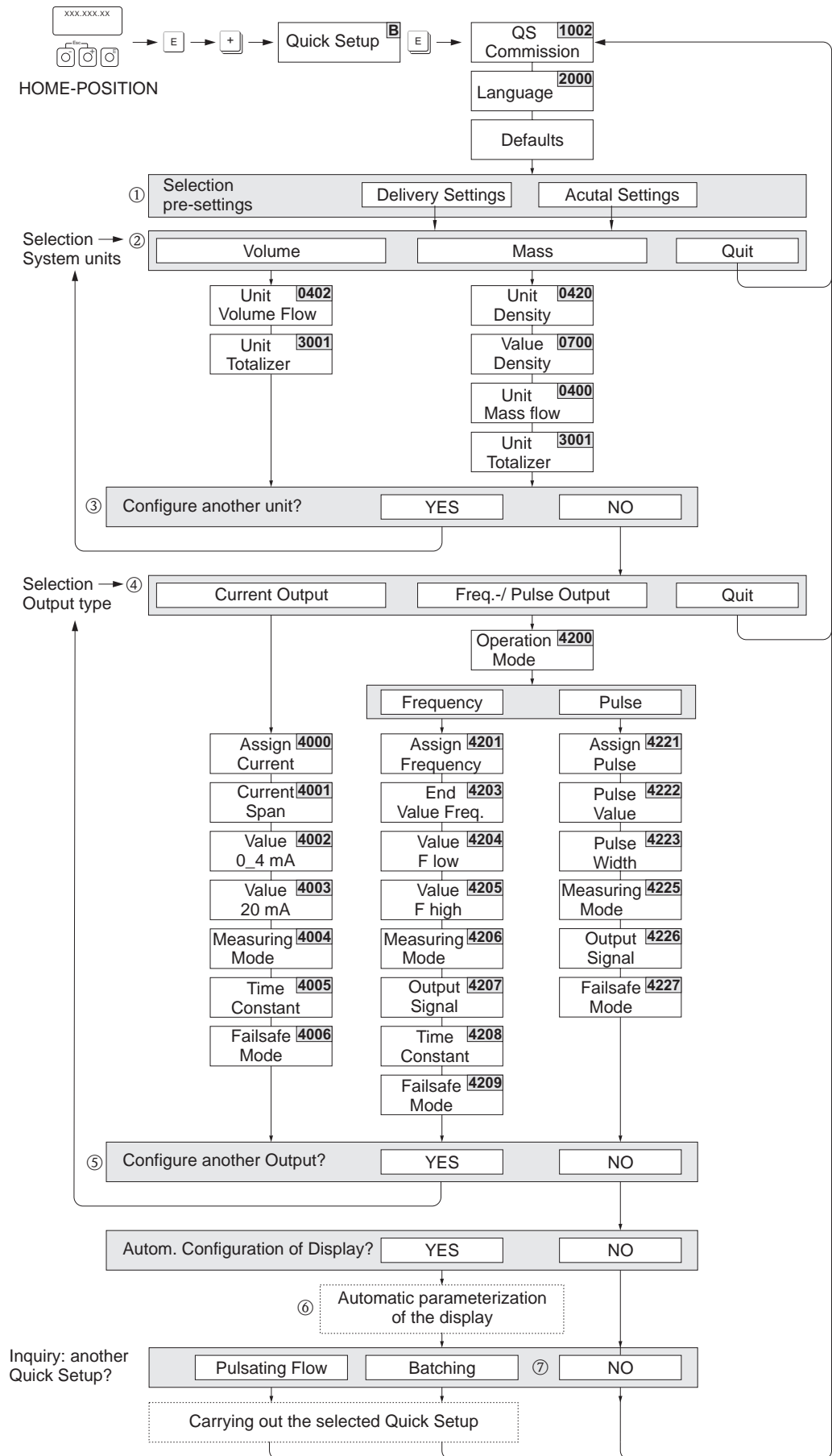

A0005523-en

Fig. 47: Quick Setup for straightforward commissioning

6.3.2 "Pulsating flow" Quick Setup menu



Note!

The "Pulsating flow" Quick Setup is only available if the device has a current output or a pulse/frequency output.

Certain pumps of a construction which necessitates a pulsating pumping action, such as reciprocating, peristaltic and cam-type pumps, create a flow characterized by severe periodic fluctuations. Negative flows can occur with pumps of these types on account of the closing volume of the valves or valve leaks.



Note!

Before carrying out the "Pulsating Flow" Quick Setup, the "Commissioning" Quick Setup must be executed → 73

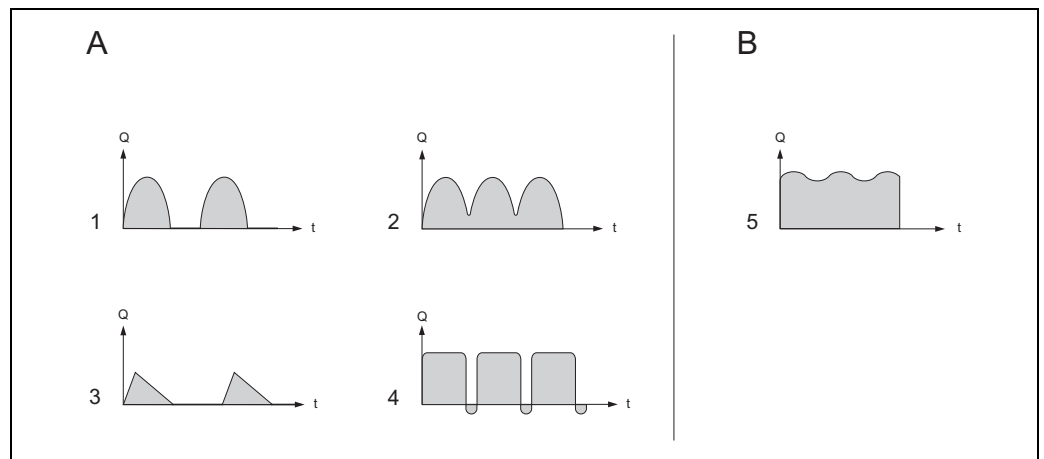

Fig. 48: Flow characteristics of various types of pump

A with severely pulsating flow
B with slightly pulsating flow

- 1 1-cylinder cam pump
- 2 2-cylinder cam pump
- 3 Magnetic pump
- 4 Peristaltic pump, flexible connecting hose
- 5 Multi-cylinder reciprocating pump

Severely pulsating flow

Once several device functions have been configured in the "Pulsating Flow" Quick Setup menu, flow fluctuations can be compensated over the entire flow range and pulsating liquid flows measured correctly. The following describes in detail how to use this Quick Setup menu.



Note!

It is always advisable to work run the "Pulsating Flow" Quick Setup if there is any uncertainty about the exact flow characteristic.

Slightly pulsating flow

If flow fluctuations are no more than minor, as is the case, for example with gear-type, three-cylinder or multi-cylinder pumps, it is **not** absolutely necessary to work through the "Pulsating Flow" menu.

In cases of this nature, however, it is advisable to adapt the functions listed below (see "Description of Device Functions" manual) to suit local process conditions in order to ensure a stable, unvarying output signal. This applies particularly to the current output:

- Measuring system damping: SYSTEM DAMPING function → increase the value
- Current output damping: TIME CONSTANT function → increase the value

Using the "Pulsating Flow" Quick Setup menu

This Quick Setup menu guides you systematically through the setup procedure for all the device functions that have to be configured for measuring pulsating flows. Note that this has no effect on values already configured, such as measuring range, current range or full scale value.

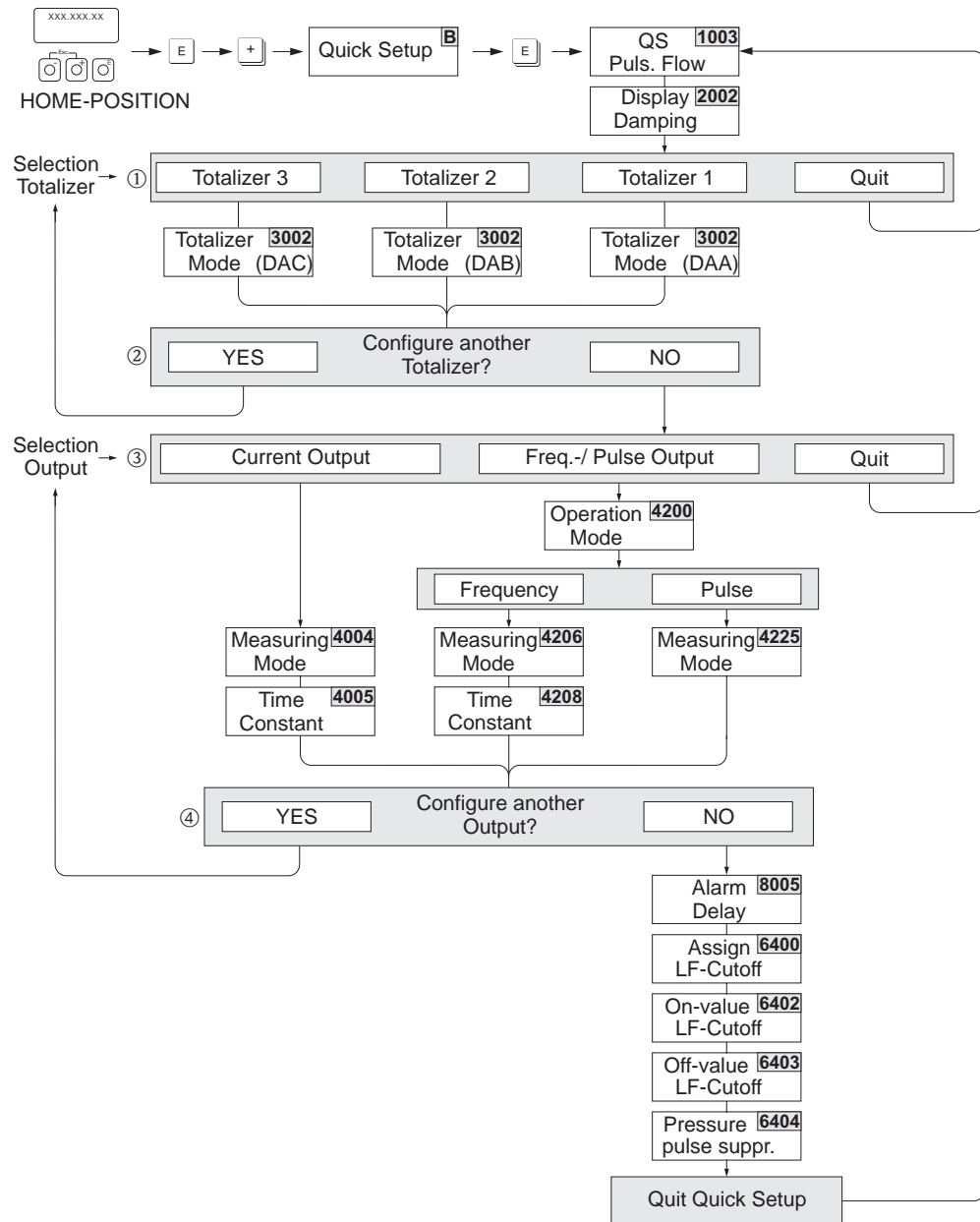

A0005524-en

Fig. 49: Quick Setup for measuring severely pulsating flows. Recommended settings see next page

- ① Only the output not yet configured in the current setup is offered for selection in the second cycle.
- ② The "YES" option remains visible until both outputs have been parameterized. "NO" is the only option displayed when no further outputs are available.
- ③ Only the outputs not yet configured in the current Setup are offered for selection in each cycle.
- ④ The "YES" option remains visible until all the outputs have been configured. "NO" is the only option displayed when no further outputs are available.



Note!

- The display returns to the cell QUICK SETUP PULSATING FLOW (1003) if you press the ESC key () during parameter interrogation.
- You can call up this setup menu either directly from the Commissioning Quick Setup menu or manually by means of the function QUICK SETUP PULSATING FLOW (1003).

"Pulsating flow" Quick Setup menu		
HOME position → → MEASURED VARIABLE → → QUICK SETUP → → QS PULSATING FLOW (1003)		
Function No.	Function name	Select using Go to next function using
1003	QS-PULS FLOW	YES After is pressed by way of confirmation, the quick setup menu calls up all the subsequent functions in succession.



Basic configuration		
2002	DISPLAY DAMPING	3 s
3002	TOTALIZER MODE (DAA)	BALANCE (Totalizer 1)
3002	TOTALIZER MODE (DAB)	BALANCE (Totalizer 2)
3002	TOTALIZER MODE (DAC)	BALANCE (Totalizer 3)
Signal type for "CURRENT OUTPUT 1 to n"		
4004	MEASURING MODE	PULSATING FLOW
4005	TIME CONSTANT	1 s
Signal type for "PULSE/FREQ. OUTPUT 1 to n" (for FREQUENCY operating mode)		
4206	MEASURING MODE	PULSATING FLOW
4208	TIME CONSTANT	0 s
Signal type for "PULSE/FREQ. OUTPUT 1 to n" (for PULSE operating mode)		
4225	MEASURING MODE	PULSATING FLOW
Other settings		
8005	ALARM DELAY	0 s
6400	ASSIGN LOW FLOW CUT OFF	VOLUME FLOW
6402	ON-VALUE LOW FLOW CUT OFF	Recommended setting: $\text{On-value} \approx \frac{\text{max. full scale (per DN)}^*}{1000}$ <small>a0004432-en</small> *Full scale values → 18
6403	OFF-VALUE LOW FLOW CUT OFF	50%
6404	PRESSURE SHOCK SUPPRESSION	0 s



Back to the HOME position
 → Press and hold down Esc keys for longer than three seconds or
 → repeatedly press and release Esc keys → exit the function matrix step by step

6.3.3 "Batching" Quick Setup menu



Hinweis!

This function is only available when the additional "batching" software is installed in the measuring device (order option). You can order this software from Endress+Hauser as an accessory at a later date.

This Quick Setup menu guides you systematically through the setup procedure for all the device functions that have to be parameterized and configured for batching operation. These basic settings allow simple (one step) batching processes.

Additional settings, e.g. for the calculation of after runs or for multi-stage batching procedures, must be made via the function matrix itself (see the "Description of Device Functions" manual).



Caution!

The "Batching" Quick Setup sets certain device parameters for discontinuous measurement operation.

If the measuring instrument is used for continuous flow measurement at a later time, we recommend at you rerun the "Commissioning" and/or "Pulsating Flow" Quick Setup.



Note!

- Before carrying out the Quick Setup "Batching" the Quick Setup "Commissioning" has to be executed. → 73
- You can find detailed information on the batching functions in the separate "Description of Device Functions" manual".
- You can also directly control filling process using the local display. During Quick Setup, an appropriate dialog appears concerning the automatic display configuration. Acknowledge this by clicking "YES".

This assigns special batching functions (START, PRESET, MATRIX) to the bottom line of the display. These can be directly executed onsite using the three operating keys (/ /). Therefore, the measuring device can be fully deployed in the field as a "batch controller".

→ Page 56

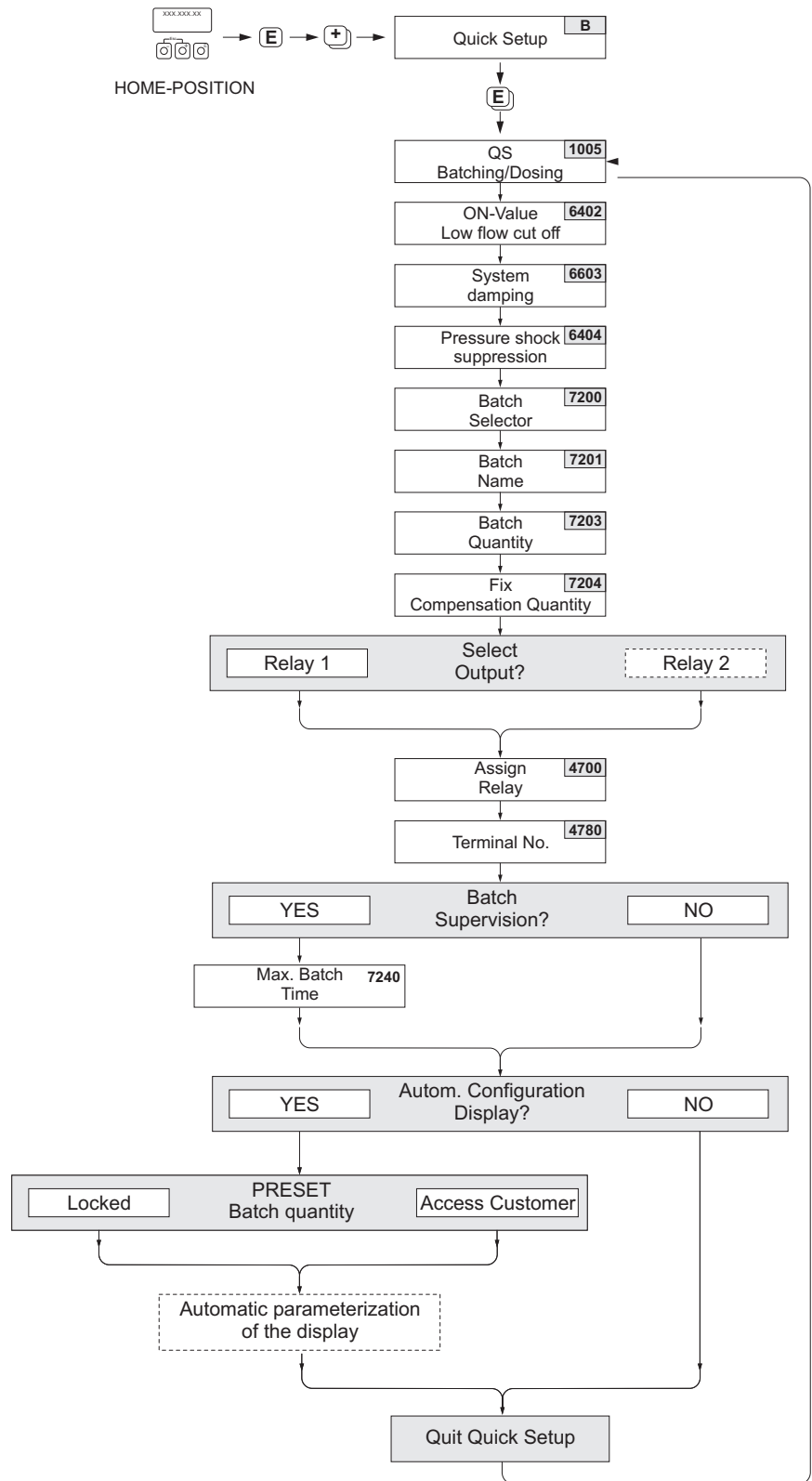













Fig. 50: Quick Setup "Batching". Recommended settings see next page

a0004433-en

Recommended settings

"Batching" Quick Setup menu		
HOME-Position →  → MEASURED VARIABLE →  → QUICK SETUP →  → QUICK SETUP BATCHING (1005)		
Function No.	Function name	Setting to be selected () (to next function with )
1005	QUICK SETUP BATCHING / DOSING	YES After  is pressed by way of confirmation, the Quick Setup menu calls up all the subsequent functions in succession.
▼		
 Note! Functions with a gray background are configured automatically (by the measuring system itself)		
6400	ASSIGN LOW FLOW CUTOFF	VOLUME FLOW
6402	ON-VALUE LOW FLOW CUTOFF	Recommended settings see on →  77 in function 6402.
6403	OFF-VALUE LOW FLOW CUTOFF	50%
6603	SYSTEM DAMPING	9  Note! The parameter has to be optimized for highly accurate and short filling processes: to do this, put the setting to "0".
6404	PRESSURE SHOCK SUPPRESSION	0 seconds
7200	BATCH SELECTOR	BATCH #1
7201	BATCH NAME	BATCH #1
7202	ASSIGN BATCH VARIABLE	Volume
7203	BATCH QUANTITY	0
7204	FIX COMPENSATION QUANTITY	0
7205	COMPENSATION MODE	OFF
7208	BATCH STAGES	1
7209	INPUT FORMAT	Value input
4700	ASSIGN RELAY	BATCH VALVE 1
4780	TERMINAL NUMBER	Output (display only)
7220	OPEN VALVE 1	0% or 0 [unit]
7240	MAXIMUM BATCH TIME	0 seconds (= switched off)
7241	MINIMUM BATCH QUANTITY	
7242	MAXIMUM BATCH QUANTITY	
2200	ASSIGN (main line)	BATCH NAME
2220	ASSIGN (Multiplex main line)	OFF
2400	ASSIGN (additional line)	BATCH DOWNWARDS
2420	ASSIGN (Multiplex additional line)	OFF
2600	ASSIGN (information line)	BATCHING KEYS
2620	ASSIGN (Multiplex information line)	OFF
▼		
Back to the HOME position: → Press and hold down Esc key  for longer than three seconds or → Repeatedly press and release Esc key  → Exit the function matrix step by step		

6.3.4 Data backup/transmission

Using the T-DAT SAVE/LOAD function, you can transfer data (device parameters and settings) between the T-DAT (exchangeable memory) and the EEPROM (device storage unit).

This is required in the following instances:

- Creating a backup: current data are transferred from an EEPROM to the T-DAT.
- Replacing a transmitter: current data are copied from an EEPROM to the T-DAT and then transferred to the EEPROM of the new transmitter.
- Duplicating data: current data are copied from an EEPROM to the T-DAT and then transferred to EEPROMs of identical measuring points.



Note!

For information on installing and removing the T-DAT → [102](#)

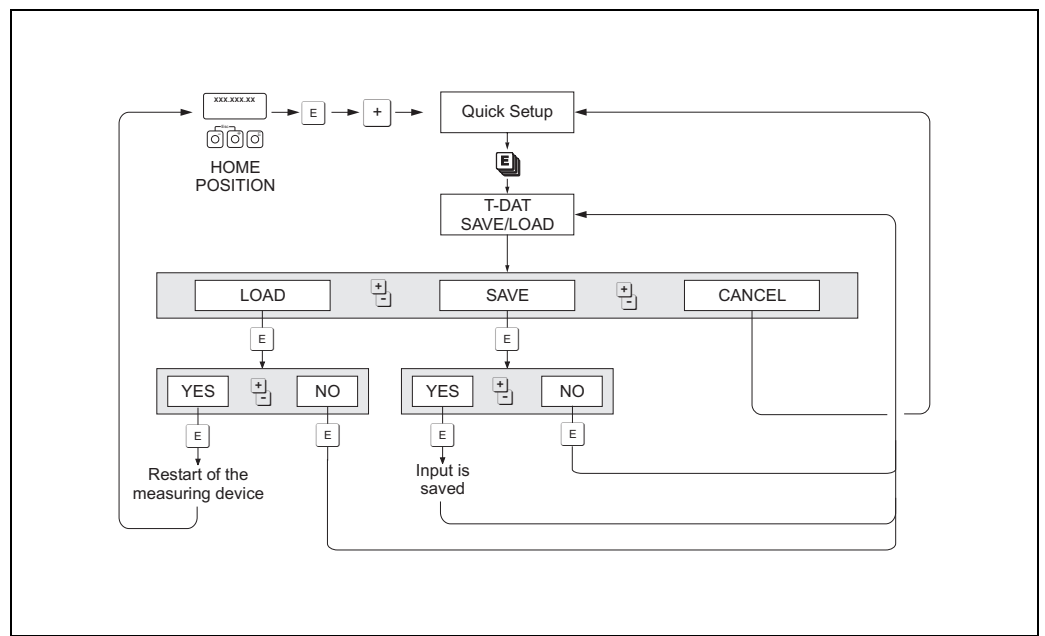

Fig. 51: Data backup/transmission with T-DAT SAVE/LOAD function

Information on the LOAD and SAVE options available:

LOAD: Data are transferred from the T-DAT to the EEPROM.



Note!

- Any settings already saved on the EEPROM are deleted.
- This option is only available, if the T-DAT contains valid data.
- This option can only be executed if the software version of the T-DAT is the same or newer than that of the EEPROM. Otherwise, the error message "TRANSM. SW-DAT" appears after restarting and the LOAD function is then no longer available.

SAVE:

Data are transferred from the EEPROM to the T-DAT

6.4 Configuration

6.4.1 Current outputs: active/passive

The current outputs can be configured as "active" or "passive" by means of various jumpers on the I/O board or on the current submodule.



Caution!

The configuration of the current outputs as "active" or "passive" is only possible on non-Ex i I/O boards. Ex i I/O boards are permanently wired as "active" or "passive". See Table → 47



Warning!

Risk of electric shock. Exposed components carry dangerous voltages. Make sure that the power supply is switched off before you remove the cover of the electronics compartment.

1. Switch off power supply
2. Remove the I/O board → 102
3. Position jumpers → 52, → 53



Caution!

- Risk of destroying the measuring device. Set the jumpers exactly as shown in the diagrams. Incorrectly set jumpers can cause overcurrents that would destroy either the measuring device or external devices connected to it.
- Note that the position of the current submodule on the I/O board can vary, depending on the version ordered, and that the terminal assignment in the connection compartment of the transmitter varies accordingly → 47.

4. Installation of the I/O board is the reverse of the removal procedure.

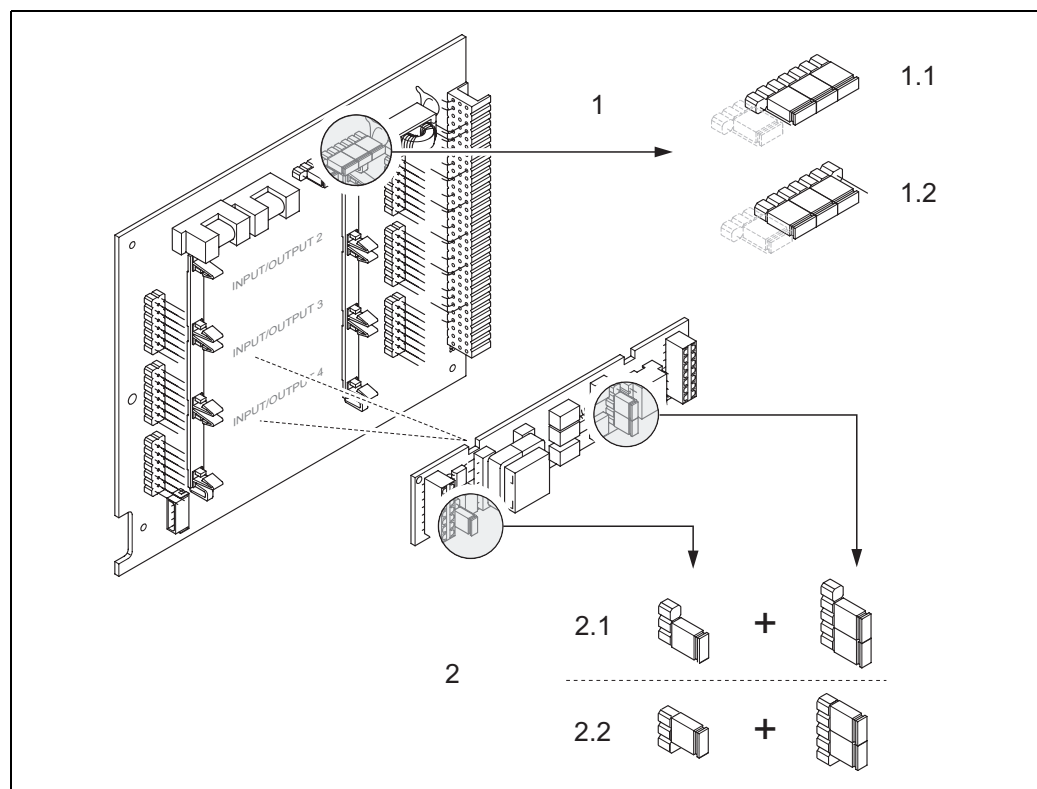

Fig. 52: Configuring the current outputs with the aid of jumpers (convertible I/O board)

- 1 Current output 1 with HART
 - 1.1 Active current output (factory setting)
 - 1.2 Passive current output
- 2 Current output 2 (optional, plug-in module)
 - 2.1 Active current output (factory setting)
 - 2.2 Passive current output

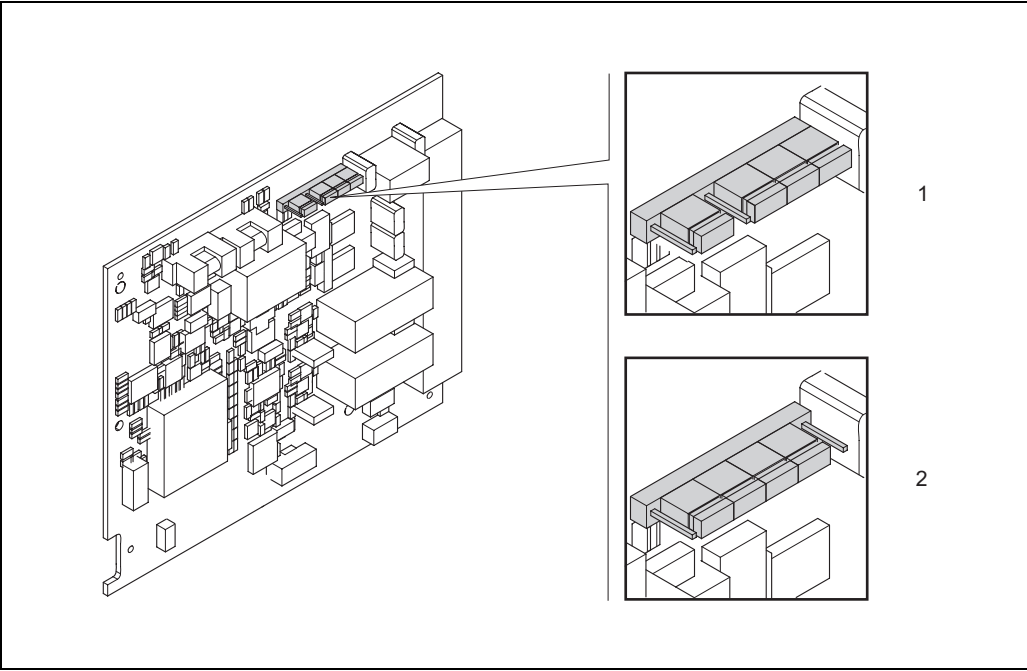

Fig. 53: Configuring the current output with the aid of jumpers (fixed I/O board)

- 1 Active current output (factory setting)
- 2 Passive current output

6.4.2 Current input: active/passive

The current input can be configured as "active" or "passive" by means of various jumpers on the current input submodule.



Warning!

Risk of electric shock. Exposed components carry dangerous voltages. Make sure that the power supply is switched off before you remove the cover of the electronics compartment.

1. Switch off power supply
2. Remove the I/O board → [102](#)
3. Position jumpers → [54](#)



Caution!

- Risk of destroying the measuring device. Set the jumpers exactly as shown in the diagram. Incorrectly set jumpers can cause overcurrents that would destroy either the measuring device or external devices connected to it.
- Note that the position of the current input submodule on the I/O board can vary, depending on the version ordered, and that the terminal assignment in the connection compartment of the transmitter varies accordingly → [47](#).

4. Installation of the I/O board is the reverse of the removal procedure.

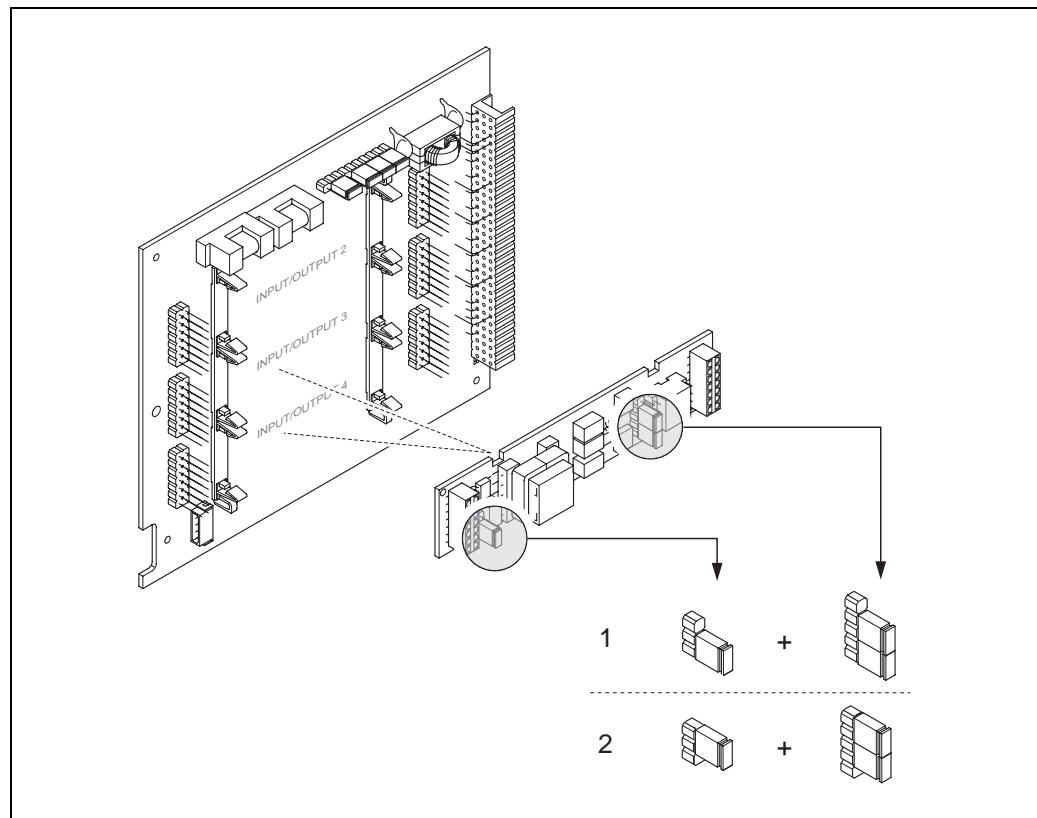

Fig. 54: Configuring the current input with the aid of jumpers (I/O board)

- 1 Active current input (factory setting)
- 2 Passive current input

6.4.3 Relay contacts: Normally closed/normally open

The relay contact can be configured as normally open (NO or make) or normally closed (NC or break) contacts by means of two jumpers on the I/O board or on the relay submodule respectively. This configuration can be called up at any time with the ACTUAL STATUS RELAY function (4740).



Warning!

Risk of electric shock. Exposed components carry dangerous voltages. Make sure that the power supply is switched off before you remove the cover of the electronics compartment.

1. Switch off power supply
2. Remove the I/O board → 102
3. Position jumpers → 55, → 56



Caution!

- If you change the setting you must always change the positions of **both** jumpers. Set the jumpers exactly as indicated.
- Note that the position of the relay submodule on the I/O board can vary, depending on the version ordered, and that the terminal assignment in the connection compartment of the transmitter varies accordingly → 47.

4. Installation of the I/O board is the reverse of the removal procedure.

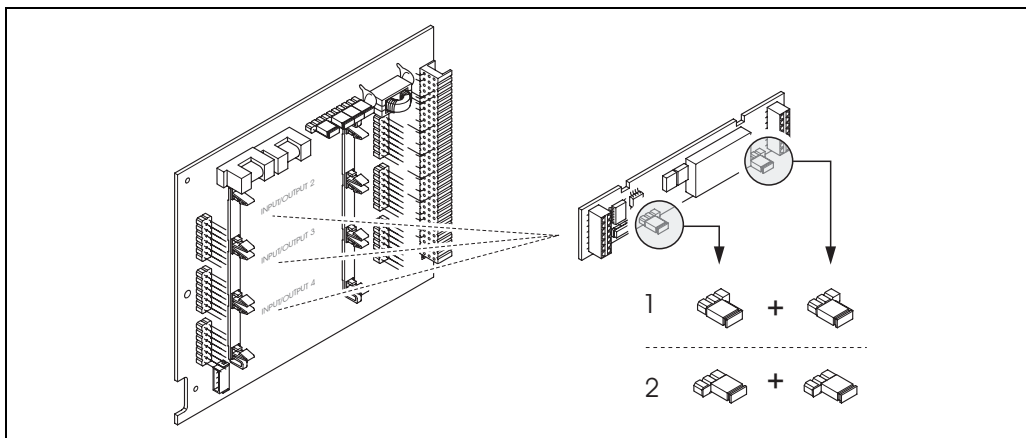

Fig. 55: Configuring relay contacts (NC/NO) for the flexible module board.

- 1 Configured as NO contact (factory setting, relay 1)
- 2 Configured as NC contact (factory setting, relay 2, if installed)

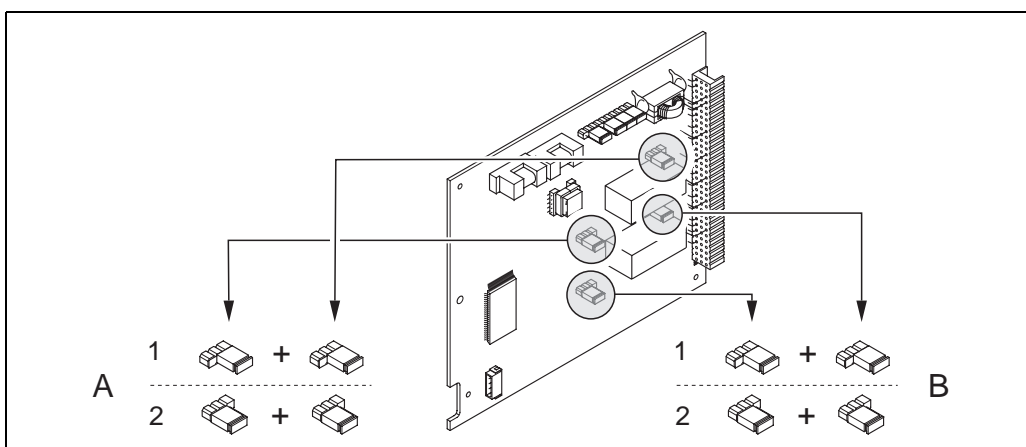

Fig. 56: Configuring relay contacts (NC/NO) for the fixed module board.

A = relay 1; B = relay 2

- 1 Configured as NO contact (factory setting, relay 1)
- 2 Configured as NC contact (factory setting, relay 2)

6.5 Adjustment

6.5.1 Empty-pipe/Full-pipe adjustment

Flow cannot be measured correctly unless the measuring pipe is completely full.

This status can be monitored at all times with the Empty Pipe Detection function:

- EPD = Empty Pipe Detection (with the help of an EPD electrode)
- OED = Open Electrode Detection (Empty Pipe Detection with the help of the measuring electrodes, if the sensor is not equipped with an EPD electrode or the orientation is not suitable for using EPD).



Caution!

A **detailed** description and other helpful hints for the empty-pipe/full-pipe adjustment procedure can be found in the separate "Description of Device Functions" Manual:

- EPD/OED ADJUSTMENT (6481) → Carrying out the adjustment.
- EPD (6420) → Switching on and off EPD/OED.
- EPD RESPONSE TIME (6425) → Input of the response time for EPD/OED.



Note!

- The EPD function is not available unless the sensor is fitted with an EPD electrode.
- The devices are already calibrated at the factory with water (approx. 500 µS/cm). If the liquid conductivity differs from this reference, empty-pipe/full-pipe adjustment has to be performed again on site.
- The default setting for EPD/OED when the devices are delivered is OFF; the function has to be activated if required.
- The EPD/OED process error can be output by means of the configurable relay outputs.

Performing empty-pipe and full-pipe adjustment (EPD/OED)

1. Select the corresponding function in the function matrix:
HOME → → → BASIC FUNCTIONS → → → PROCESS PARAMETERS → → → ADJUSTMENT → → EPD/OED ADJUSTMENT
2. Empty the piping. In case of an EPD adjustment, the wall of the measuring tube should be wetted with fluid for the adjustment procedure but this is not the case with an OED adjustment!
3. Start empty-pipe adjustment: Select "EMPTY PIPE ADJUST" or "OED EMPTY ADJUST" and press to confirm.
4. After empty-pipe adjustment, fill the piping with fluid.
5. Start full-pipe adjustment: Select "FULL PIPE ADJUST" or "OED FULL ADJUST" and press to confirm.
6. Having completed the adjustment, select the setting "OFF" and exit the function by pressing .
7. Now select the "EPD" function (6420). Switch on Empty Pipe Detection by selecting the following settings:
 - EPD → Select ON STANDARD or ON SPECIAL and press to confirm.
 - OED → Select OED and confirm with .



Caution!

The adjustment coefficients must be valid before you can activate the EPD/OED function. If adjustment is incorrect the following messages might appear on the display:

- ADJUSTMENT FULL = EMPTY
The adjustment values for empty pipe and full pipe are identical. In such instances, empty-pipe adjustment/full-pipe adjustment **must** be carried out again.
- ADJUSTMENT NOT OK
Adjustment is not possible because the fluid's conductivity is out of range.

6.6 Data storage devices

At Endress+Hauser, the term HistoROM refers to various types of data storage modules on which process and measuring device data are stored. By plugging and unplugging such modules, device configurations can be duplicated onto other measuring devices to cite just one example.

6.6.1 HistoROM/S-DAT (sensor DAT)

The S-DAT is an exchangeable data storage device in which all sensor data are stored, i.e., nominal diameter, serial number, calibration factor, zero point.

6.6.2 HistoROM/T-DAT (transmitter DAT)

The T-DAT is an exchangeable data storage device in which all transmitter parameters and settings are stored.

Storing of specific parameter settings from the device memory (EEPROM) to the T-DAT module and vice versa must be carried out by the user (= manual save function). Detailed instructions regarding this can be found on →  81.

6.6.3 F-CHIP (function chip)

The F-CHIP is a microprocessor component which contains additional software packages which are used to enhance the functionality and therefore the range of application of the transmitter.

If an upgrade is carried out at a later stage, the F-CHIP can be ordered as an accessory and can simply be inserted into the I/O board. After startup, the transmitter can access this software immediately.

Accessories →  89

Inserting into the I/O board →  101



Caution!

To avoid any confusion, once the F-CHIP has been put on the I/O board, it is labeled with the transmitter's serial number i.e. the F-CHIP can then no longer be used for another measuring device.

7 Maintenance

No special maintenance work is required.

7.1 Exterior cleaning

When cleaning the exterior of measuring devices, always use cleaning agents that do not attack the surface of the housing or the seals.

7.2 Seals

The seals in the Promag H sensor should be replaced periodically, particularly when molded seals (aseptic version) are used!

The interval between replacements depends on the frequency of the cleaning cycles and on the temperature of the fluid and of the cleaning process.

Replacement seals (accessory) →  89.

8 Accessories

Various accessories, which can be ordered separately from Endress+Hauser, are available for the transmitter and the sensor. Your Endress+Hauser service organization can provide detailed information on the order code of your choice.

8.1 Device-specific accessories

Accessory	Description	Order code
Transmitter Promag 53	Transmitter for replacement or for stock. Use the order code to define the following specifications: <ul style="list-style-type: none"> – Approvals – Degree of protection / version – Cable type for remote version – Cable entries – Display / power supply / operation – Software – Outputs / inputs 	53XXX – XXXXX * * * * * * * *
Software packages for Promag 53	Software add-ons on F-CHIP, can be ordered individually: <ul style="list-style-type: none"> – Electrode Cleaning Circuitry (ECC) – Batching 	DK5SO-*
Conversion kit for outputs/inputs	Conversion kit with appropriate plug-in point modules to change the current input/output configuration to a new version.	DKUI-*

8.2 Accessories specific to measuring principle

Accessory	Description	Order code
Mounting kit for Promag 53 transmitter	Mounting kit for wall-mount housing (remote version). Suitable for: <ul style="list-style-type: none"> ■ Wall mounting ■ Pipe mounting ■ Panel mounting Mounting set for aluminum field housing. Suitable for Pipe mounting.	DK5WM – *
Cable for remote version	Coil and signal cables, various lengths. Reinforced cable on request.	DK5CA – * * *
Ground cable for Promag W/Promag P	A set consists of two ground cables.	DK5GC – * * *
Ground disk for Promag W/Promag P	Ground disk for potential equalization.	DK5GD – * * * * *
Mounting kit for Promag H	Mounting kit for Promag H, consisting of: <ul style="list-style-type: none"> ■ 2 Process connections ■ Screws ■ Seals 	DKH * * – * * * * *
Adapter connection for Promag A/H	Adapter connections for installation of Promag 53 H instead of Promag 30/33 A or Promag 30/33 H/DN 25.	DK5HA – * * * * * * *
Grounding rings for Promag H	If the process connections are made of PVC or PVDF, ground rings are necessary to ensure that potential is matched. A set comprises 2 ground rings.	DK5HR – * * *
Seal set for Promag H	For regular replacement of seals in the Promag H sensor.	DK5HS – * * *
Wall mounting kit Promag H	Wall mounting kit for Promag H transmitter.	DK5HM – * * *
Welding jig for Promag H	Weld nipple as process connection: Welding jig for installation in piping.	DK5HW – * * *

8.3 Communication-specific accessories

Accessory	Description	Order code
HART Communicator Field Xpert SFX 100	Handheld terminal for remote configuration and for obtaining measured values via the 4 to 20 mA HART current output. Contact your Endress+Hauser representative for more information.	SFX100 – *****
Fieldgate FXA320	Gateway for remote interrogation of HART sensors and actuators via Web browser: <ul style="list-style-type: none"> ■ 2-channel analog input (4 to 20 mA) ■ 4 binary inputs with event counter function and frequency measurement ■ Communication via modem, Ethernet or GSM ■ Visualization via Internet/Intranet in Web browser and/or WAP cellular phone ■ Limit value monitoring with alarm by e-mail or SMS ■ Synchronized time stamping of all measured values. 	FXA320 – *****
Fieldgate FXA520	Gateway for remote interrogation of HART sensors and actuators via Web browser: <ul style="list-style-type: none"> ■ Web server for remote monitoring of up to 30 measuring points ■ Intrinsically safe version [Ex ia]IIC for applications in hazardous areas ■ Communication via modem, Ethernet or GSM ■ Visualization via Internet/Intranet in Web browser and/or WAP cellular phone ■ Limit value monitoring with alarm by e-mail or SMS ■ Synchronized time stamping of all measured values ■ Remote diagnosis and remote configuration of connected HART devices 	FXA520 – *****
FXA195	The Commubox FXA195 connects intrinsically safe Smart transmitters with HART protocol to the USB port of a personal computer. This makes the remote operation of the transmitters possible with the aid of configuration programs (e.g. FieldCare). Power is supplied to the Commubox by means of the USB port	FXA195 – *

8.4 Service-specific accessories

Accessory	Description	Order code
Applicator	Software for selecting and configuring flowmeters. Applicator can be downloaded from the Internet or ordered on CD-ROM for installation on a local PC. Contact your Endress+Hauser representative for more information.	DXA80 – *
Fieldcheck	Tester/simulator for testing flowmeters in the field. When used in conjunction with the "FieldCare" software package, test results can be imported into a database, printed and used for official certification. Contact your Endress+Hauser representative for more information.	50098801
FieldCare	FieldCare is Endress+Hauser's FDT-based plant asset management tool. It can configure all intelligent field devices in your plant and supports you in the administration of these devices. Through the use of status information, it is also an easy but effective means of monitoring the status of these devices.	See product list on the Endress+Hauser website: www.endress.com
FXA193	Service interface of device to the PC for operation via FieldCare.	FXA193 – *
Memograph M graphic display recorder	The Memograph M graphic display recorder provides information on all relevant process variables: Measuring values are recorded reliably, limit values monitored and measuring points analyzed. The data are stored in the 256 MB internal memory and also on an SD card or USB stick. The PC software package ReadWin® 2000, which is supplied as standard, is used for configuration, visualization and storage of the recorded data.	RSG40-*****

9 Troubleshooting

9.1 Troubleshooting instructions

If faults occur after commissioning or during operation, always start troubleshooting with the checklist below. The routine takes you directly to the cause of the problem and the appropriate remedial measures.



Caution!

In the event of a serious fault, a flowmeter might have to be returned to the manufacturer for repair. The necessary procedures must be carried out before you return the device to Endress+Hauser → 6.

Always enclose a duly completed "Declaration of Contamination" form. You will find a preprinted blank of this form at the back of this manual.

Check the display	
No display visible and no output signals present.	<ol style="list-style-type: none"> 1. Check the supply voltage → terminals 1, 2 2. Check the power line fuse → 106 85 to 260 V AC: 0.8 A slow-blow / 250 V 20 to 55 V AC / 16 to 62 V DC: 2 A slow-blow / 250 V 3. Measuring electronics defective → order spare parts → 101
No display visible, but output signals are present.	<ol style="list-style-type: none"> 1. Check whether the ribbon-cable connector of the display module is correctly plugged into the amplifier board → 101 2. Display module defective → order spare parts → 101 3. Measuring electronics defective → order spare parts → 101
Display texts are in a foreign language.	Switch off power supply. Press and hold down both the buttons and switch on the measuring device. The display text will appear in English (default) and is displayed at maximum contrast.
Measured value indicated, but no signal at the current or pulse output.	Electronics board defective → order spare parts → 101



Error messages on display	
Errors which occur during commissioning or operation are displayed immediately. Error messages consist of a variety of icons. The meanings of these icons are as follows (example): <ul style="list-style-type: none"> - Error type: S = system error, P = process error - Error message type: = fault message, = notice message - EMPTY PIPE = type of error, e.g. measuring tube is only partly filled or completely empty - 03:00:05 = duration of error occurrence (in hours, minutes and seconds) - #401 = error number 	
Caution! <ul style="list-style-type: none"> ■ Also observe the information on → 59 ■ The measuring system interprets simulations and positive zero return as system errors, but displays them only as a notice message. 	
Error number: No. 001 – 399 No. 501 – 699	System error (device error) has occurred → 93
Error number: No. 401 – 499	Process error (application error) has occurred → 96



Other errors (without error message)	
Some other errors have occurred.	Diagnosis and rectification → 98

9.2 System error messages

Serious system errors are **always** recognized by the device as "Fault message", and are shown as a lightning flash (⚡) on the display. Fault messages immediately affect the outputs.



Caution!

In the event of a serious fault, a flowmeter might have to be returned to the manufacturer for repair. The necessary procedures on → 109 must be carried out before you return a flowmeter to Endress+Hauser. Always enclose a duly completed "Declaration of Contamination" form. You will find a master copy of this form at the back of this manual.





Note!

Also observe the information on → 59.

No.	Error message / Type	Cause	Remedy (spare part → 101)
S = System error ⚡ = Fault message (with an effect on the outputs) ! = Notice message (without an effect on the outputs)			
No. # 0xx → Hardware error			
001	S: CRITICAL FAILURE ⚡: # 001	Serious device error	Replace the amplifier board.
011	S: AMP HW EEPROM ⚡: # 011	Amplifier: Defective EEPROM	Replace the amplifier board.
012	S: AMP SW EEPROM ⚡: # 012	Amplifier: Error accessing EEPROM data	The EEPROM data blocks in which an error has occurred are displayed in the TROUBLESHOOTING function. Press Enter to acknowledge the errors in question; default values are automatically inserted instead of the errored parameter values. Note! The measuring device has to be restarted if an error has occurred in a totalizer block (see error No. 111 / CHECKSUM TOTAL).
031	S: SENSOR HW DAT ⚡: # 031	1. S-DAT is not plugged into the amplifier board correctly (or is missing). 2. S-DAT is defective.	1. Check whether the S-DAT is correctly plugged into the amplifier board. 2. Replace the S-DAT if it is defective. Check that the new replacement DAT is compatible with the measuring electronics. Check the: – Spare part set number – Hardware revision code 3. Replace measuring electronics boards if necessary. 4. Plug the S-DAT into the amplifier board.
032	S: SENSOR SW DAT ⚡: # 032		
041	S: TRANSM. HW-DAT ⚡: # 041	Transmitter DAT: 1. T DAT is not correctly plugged into the amplifier board (or is missing). 2. T-DAT is defective.	1. Check whether the T-DAT is correctly plugged into the amplifier board. 2. Replace the T-DAT if it is defective. Check that the new replacement DAT is compatible with the measuring electronics. Check the: – Spare part set number – Hardware revision code 3. Replace measuring electronics boards if necessary. 4. Plug the T-DAT into the amplifier board.
042	S: TRANSM. SW-DAT ⚡: # 042	Transmitter DAT: Error accessing the calibration values stored in the S-DAT.	
061	S: HW F-CHIP ⚡: # 061	Transmitter F-CHIP: 1. F-CHIP is defective. 2. F-CHIP is not plugged into the I/O board or is missing.	1. Replace the F-CHIP. Accessories → 89 2. Plug the F-CHIP into the I/O board → 102

No.	Error message / Type	Cause	Remedy (spare part → 101)
No. # 1xx → Software error			
101	S: GAIN ERROR AMP !/: # 101	Gain deviation compared to reference gain > 25%.	Replace the amplifier board.
111	S: CHECKSUM TOTAL !/: # 111	Totalizer checksum error.	1. Restart the measuring device. 2. Replace the amplifier board if necessary.
121	S: A / C COMPATIB. !/: # 121	Due to different software versions, I/O board and amplifier board are only partially compatible (possibly restricted functionality).  Note! – The indication on the display as notice message appears only for 30 seconds (with listing in "Previous system condition" function). – This condition can occur if only one electronics board has been exchanged; the extended software functionality is not available. The previously existing software functionality is still working and the measurement possible.	Module with lower software version has either to be updated by FieldCare with the required software version or the module has to be replaced.
No. # 2xx → Error in DAT / no communication			
205	S: LOAD T-DAT !/: # 205	Transmitter DAT: Data backup (downloading) to T-DAT failed, or error when accessing (uploading) the calibration values stored in the T-DAT.	1. Check whether the T-DAT is correctly plugged into the amplifier board → 102 2. Replace the T-DAT if it is defective. Before replacing the DAT, check that the new, replacement DAT is compatible with the measuring electronics. Check the: – Spare part set number – Hardware revision code 3. Replace measuring electronics boards if necessary.
206	S: SAVE T-DAT !/: # 206		
261	S: COMMUNICATION I/O !/: # 261	No data reception between amplifier and I/O board or faulty internal data transfer.	Check the BUS contacts.
No. # 3xx → System limits exceeded			
321	S: TOL. COIL CURR. !/: # 321	Sensor: Coil current is out of tolerance.	 Warning! Switch off power supply before manipulating the coil current cable, coil current cable connector or measuring electronics boards! Remote version: 1. Check wiring of terminals 41/42 → 40 2. Check coil current cable connector. Compact and remote version: If the error can not be resolved, please contact your local Endress+Hauser service organization.
339 to 342	S: STACK CUR OUT n !/: # 339 to 342	The temporarily buffered flow portions (measuring mode for pulsating flow) could not be cleared or output within 60 seconds.	1. Change the upper or lower limit setting, as applicable. 2. Increase or reduce flow, as applicable. Recommendations in the event of fault category = FAULT MESSAGE (!/) ■ Configure the fault response of the output to "ACTUAL VALUE" so that the temporary buffer can be cleared. ■ Clear the temporary buffer by the measures described under Item 1.
343 to 346	S: STACK FREQ. OUT n !/: # 343 to 346		
347 to 350	S: STACK PULSE OUT n !/: # 343 to 346		
347 to 350	S: STACK PULSE OUT n !/: # 343 to 346	The temporarily buffered flow portions (measuring mode for pulsating flow) could not be cleared or output within 60 seconds.	1. Increase the setting for pulse weighting 2. Increase the max. pulse frequency if the totalizer can handle a higher number of pulses. 3. Increase or reduce flow, as applicable. Recommendations in the event of fault category = FAULT MESSAGE (!/) ■ Configure the fault response of the output to "ACTUAL VALUE" so that the temporary buffer can be cleared. ■ Clear the temporary buffer by the measures described under Item 1.

No.	Error message / Type	Cause	Remedy (spare part →  101)
351 to 354	S: CURRENT RANGE n !: # 351 to 354	Current output: flow is out of range.	<ol style="list-style-type: none"> 1. Change the upper or lower limit setting, as applicable. 2. Increase or reduce flow, as applicable.
355 to 358	S: FREQ. RANGE n !: # 355 to 358	Frequency output: flow is out of range.	<ol style="list-style-type: none"> 1. Change the upper or lower limit setting, as applicable. 2. Increase or reduce flow, as applicable.
359 to 362	S: PULSE RANGE !: # 359 to 362	Pulse output: the pulse output frequency is out of range.	<ol style="list-style-type: none"> 1. Increase the setting for pulse weighting 2. When selecting the pulse width, choose a value that can still be processed by a connected counter (e.g. mechanical counter, PLC etc.). <i>Determine the pulse width:</i> <ul style="list-style-type: none"> – Variant 1: Enter the minimum duration that a pulse must be present at the connected counter to ensure its registration. – Variant 2: Enter the maximum (pulse) frequency as the half "reciprocal value" that a pulse must be present at the connected counter to ensure its registration. Example: The maximum input frequency of the connected counter is 10 Hz. The pulse width to be entered is: $\frac{1}{2 \cdot 10 \text{ Hz}} = 50 \text{ ms}$ 3. Reduce flow.
363	S: CUR IN. RANGE !: # 363	Current input: The actual value for the current lies outside the set limits.	<ol style="list-style-type: none"> 1. Change set lower-range or upper-range value. 2. Check settings of the external sensor.
No. # 5xx → Application error			
501	S: SW.-UPDATE ACT. !: # 501	New amplifier or communication (I/O module) software version is loaded. Currently no other functions are possible.	Wait until the procedure is finished. The device will restart automatically.
502	S: UP-/DOWNLOAD ACT !: # 502	Uploading or downloading the device data via operating program. Currently no other functions are possible.	Wait until the procedure is finished.
571	S: BATCH RUNNING !: # 571	Batching is started and active (valves are open).	No measures needed (during the batching process some other functions may not be activated).
572	S: BATCH HOLD !: # 572	Batching has been interrupted (valves are closed).	<ol style="list-style-type: none"> 1. Continue batching with command "GO ON". 2. Interrupt batching with "STOP" command.
No. # 6xx → Simulation mode active			
601	S: POS. ZERO-RETURN !: # 601	Positive zero return active  Caution! This message has the highest display priority!	Switch off positive zero return
611 to 614	S: SIM. CURR. OUT. n !: # 611 to 614	Simulation current output active	Switch off simulation
621 to 624	S: SIM. FREQ. OUT. n !: # 621 to 624	Simulation frequency output active	Switch off simulation
631 to 634	S: SIM. PULSE n !: # 631 to 634	Simulation pulse output active	Switch off simulation
641 to 644	S: SIM. STAT. OUT n !: # 641 to 644	Simulation status output active	Switch off simulation
651 to 654	S: SIM. RELAY n !: # 651 to 654	Simulation relay output active.	Switch off simulation.
661	S: SIM. CURR. IN n !: # 661	Simulation current input active.	Switch off simulation.

No.	Error message / Type	Cause	Remedy (spare part → 101)
671 to 674	S: SIM. STATUS IN n !: # 671 to 674	Simulation status input active	Switch off simulation
691	S: SIM. FAILSAFE !: # 691	Simulation of response to error (outputs) active	Switch off simulation
692	S: SIM. MEASURAND !: # 692	Simulation of a measured variable active (e.g. mass flow).	Switch off simulation
698	S: DEV. TEST ACT. !: # 698	The measuring device is being checked on site via the test and simulation device.	–



9.3 Process error messages



Note!

Also observe the information on → 59.

No.	Error message / Type	Cause	Remedy (spare part → 101)
P = Process error ⚡ = Fault message (with an effect on the outputs) ! = Notice message (without an effect on the outputs)			
401	EMPTY PIPE ⚡: # 401	Measuring tube partially filled or empty	1. Check the process conditions of the plant 2. Fill the measuring tube
461	ADJ. NOT OK !: # 461	EPD calibration not possible because the fluid's conductivity is either too low or too high.	The EPD function cannot be used with fluids of this nature.
463	FULL = EMPTY ⚡: # 463	The EPD calibration values for empty pipe and full pipe are identical, therefore incorrect.	Repeat calibration, making sure procedure is correct → 86.
471	P: > BATCH TIME ⚡: # 471	The maximum permitted batching time was exceeded.	1. Increase flow rate. 2. Check valve (opening). 3. Adjust time setting to changed batch quantity. Note! If the errors listed above occur, these are displayed in the Home position flashing continuously. <ul style="list-style-type: none"> ■ General: These error messages can be reset by configuring any batching parameter. It is sufficient to confirm with the [↵] key and then the [⏏] key. ■ Batching via status input: The error message can be reset by means of a pulse. Another pulse then restarts the batching. ■ Batching via operating keys (soft keys) The error message is reset by pressing the START key. Pressing the START key a second time starts the batching process. ■ Batching via the BATCHING PROCESS function (7260): The error message can be reset by pressing the STOP, START, HOLD or GO ON keys. Pressing the START key a second time starts the batching process.

No.	Error message / Type	Cause	Remedy (spare part →  101)
472	P: >< BATCH QUANTITY !/: # 472	<ul style="list-style-type: none"> – Underbatching: The minimum quantity was not reached. – Overbatching: The maximum permitted batching quantity was exceeded. 	<p>Underbatching:</p> <ol style="list-style-type: none"> 1. Increase fixed correction quantity. 2. Valve closes too quickly with active after run correction. Enter smaller after run as mean value. 3. If the batching quantity changes, the minimum batching quantity must be adjusted. <p>Overbatching:</p> <ol style="list-style-type: none"> 1. Reduce fixed correction quantity. 2. Valve closes too slowly with active after run correction. Enter larger after run as mean value. 3. If the batching quantity changes, the maximum batching quantity must be adjusted. <p> Note! Please observe Note in error message No. 471</p>
473	P: PROGRESS NOTE !/: # 473	End of filling process approaching. The running filling process has exceeded the predefined batch quantity point for the display warning message.	No measures required (if necessary prepare to replace container).
474	P: MAX. FLOW !/: # 474	Maximum flow value entered is overshot.	Reduce the flow value.  Note! Please observe Note in error message No. 471

9.4 Process errors without messages

Symptoms	Rectification
<p> Note! You may have to change or correct certain settings in functions in the function matrix in order to rectify the fault. The functions outlined below, such as DISPLAY DAMPING, are described in detail in the "Description of Device Functions" manual.</p>	
Flow values are negative, even though the fluid is flowing forwards through the pipe.	<ol style="list-style-type: none"> Remote version: <ul style="list-style-type: none"> Switch off the power supply and check the wiring → 40 If necessary, reverse the connections at terminals 41 and 42 Change the setting in the "INSTALLATION DIRECTION SENSOR" function accordingly
Measured-value reading fluctuates even though flow is steady.	<ol style="list-style-type: none"> Check grounding and potential equalization → 49 The medium is too inhomogeneous. Check the following medium characteristics: <ul style="list-style-type: none"> Gas bubble percentage too high? Solids percentage too high? Conductivity fluctuations too high? SYSTEM DAMPING function → increase value (→ BASIC FUNCTION/SYSTEMPARAMETER/CONFIGURATION) TIME CONSTANT function → increase value (→ OUTPUTS/CURRENT OUTPUT/CONFIGURATION) DISPLAY DAMPING function → increase value (→ USER INTERFACE / CONTROL/BASIC CONFIGURATION)
Measured-value reading or measured-value output pulsates or fluctuates, e.g. because of reciprocating pump, peristaltic pump, diaphragm pump or pump with similar delivery characteristic.	<p>Run the "Pulsating flow" Quick Setup → 75 If the problem persists despite these measures, a pulsation damper will have to be installed between pump and measuring device.</p>
There are differences between the flowmeter's internal totalizer and the external metering device.	<p>This symptom is due primarily to backflow in the piping, because the pulse output cannot subtract in the STANDARD or SYMMETRY measuring modes.</p> <p>There is the following solution: The flow in both directions should be taken into account. Set the MEASURING MODE function to PULSATING FLOW for the pulse output in question.</p>
Measured-value reading shown on display, even though the fluid is at a standstill and the measuring tube is full.	<ol style="list-style-type: none"> Check grounding and potential equalization → 47 Check the fluid for presence of gas bubbles. Activate ON-VALUE LOW FLOW CUT OFF function, i.e. enter or increase on value (→ BASIC FUNCTION/PROCESSPARAMETER/CONFIGURATION).
Measured-value reading on display, even though measuring tube is empty.	<ol style="list-style-type: none"> Perform empty-pipe/full-pipe adjustment and then switch on empty pipe detection → 86 Remote version: Check the terminals of the EPD cable → 40 Fill the measuring tube.
The current output signal is always 4 mA, irrespective of the flow signal at any given time.	<ol style="list-style-type: none"> Select the BUS ADDRESS function and change the setting to "0". Low flow cutoff too high → reduce the relevant value in the ON-VALUE LOW FLOW CUT OFF function.
<p>The fault cannot be rectified or some other fault not described above has arisen.</p> <p>In these instances, please contact your Endress+Hauser service organization.</p>	<p>The following options are available for tackling problems of this nature:</p> <ul style="list-style-type: none"> <p>■ Request the services of an Endress+Hauser service technician</p> <p>If you contact our service organization to have a service technician sent out, please be ready to quote the following information:</p> <ul style="list-style-type: none"> Brief description of the fault Nameplate specifications (→ 7): order code, serial number <p>■ Returning devices to Endress+Hauser</p> <p>The necessary procedures (→ 109) must be carried out before you return a flowmeter requiring repair or calibration to Endress+Hauser.</p> <p>Always enclose a duly completed "Declaration of Conformity" form with the flowmeter. You will find a master copy of this form at the back of this manual.</p> <p>■ Replace transmitter electronics</p> <p>Components in the measuring electronics defective → order spare parts → 101</p>

9.5 Response of outputs to errors



Note!

The failsafe mode of current, pulse and frequency outputs can be customized by means of various functions in the function matrix. You will find detailed information on these procedures in the "Description of Device Functions" manual.

You can use positive zero return to reset the signals of the current, pulse and frequency outputs to their fallback value, for example when measuring has to be interrupted while a pipe is being cleaned. This function takes priority over all other device functions: simulations, for example, are suppressed.

Error response mode of outputs		
	System/process error is current	Positive zero return is activated
<p> Caution! System or process errors defined as "Notice messages" have no effect whatsoever on the inputs and outputs. See the information on → 59</p>		
Current output	<p>MINIMUM VALUE 0–20 mA → 0 mA 4–20 mA → 2 mA 4–20 mA HART → 2 mA 4–20 mA NAMUR → 3.5 mA 4–20 mA HART NAMUR → 3.5 mA 4–20 mA US → 3.75 mA 4–20 mA HART US → 3.75 mA 0–20 mA (25 mA) → 0 mA 4–20 mA (25 mA) → 2 mA 4–20 mA (25 mA) HART → 2 mA</p> <p>MAXIMUM VALUE 0–20 mA → 22 mA 4–20 mA → 22 mA 4–20 mA HART → 22 mA 4–20 mA NAMUR → 22.6 mA 4–20 mA HART NAMUR → 22.6 mA 4–20 mA US → 22.6 mA 4–20 mA HART US → 22.6 mA 0–20 mA (25 mA) → 25 mA 4–20 mA (25 mA) → 25 mA 4–20 mA (25 mA) HART → 25 mA</p> <p>HOLD VALUE Last valid value (preceding occurrence of the fault) is output.</p> <p>ACTUAL VALUE Fault is ignored, i.e. normal measured-value output on the basis of ongoing flow measurement.</p>	Output signal corresponds to "zero flow"
Pulse output	<p>FALLBACK VALUE Signal output → no pulses</p> <p>HOLD VALUE Last valid value (preceding occurrence of the fault) is output.</p> <p>ACTUAL VALUE Fault is ignored, i.e. normal measured-value output on the basis of ongoing flow measurement.</p>	Output signal corresponds to "zero flow"

Error response mode of outputs		
	System/process error is current	Positive zero return is activated
Frequency output	<p>FALLBACK VALUE Signal output → 0 Hz</p> <p>FAILSAFE LEVEL Output of the frequency specified in the FAILSAFE VALUE function (4211).</p> <p>HOLD VALUE Last valid value (preceding occurrence of the fault) is output.</p> <p>ACTUAL VALUE Fault is ignored, i.e. normal measured-value output on the basis of ongoing flow measurement.</p>	Output signal corresponds to "zero flow"
Totalizer	<p>STOP The totalizers are paused until the fault is rectified.</p> <p>ACTUAL VALUE The fault is ignored . The totalizers continue to count in accordance with the current flow value.</p> <p>HOLD VALUE The totalizers continue to count the flow in accordance with the last valid flow value (before the error occurred).</p>	Totalizer stops
Relay output	<p>Fault or power supply failure: relay → de-energized</p> <p>In the "Description of Device Functions" manual you will find detailed information on relay switching response for various configurations such as error message, flow direction, EPD, limit value, etc.</p>	No effect on relay output

9.6 Spare parts

You will find detailed troubleshooting instructions in the preceding sections → [92](#).

The measuring device, moreover, provides additional support in the form of continuous self-diagnosis and error messages.

Fault rectification can entail replacing defective components with tested spare parts. The illustration below shows the available scope of spare parts.



Note!

You can order spare parts directly from your Endress+Hauser service organization by providing the serial number printed on the transmitter nameplate → [7](#).

Spare parts are shipped as sets comprising the following parts:

- Spare part
- Additional parts, small items (screws, etc.)
- Mounting instructions
- Packaging

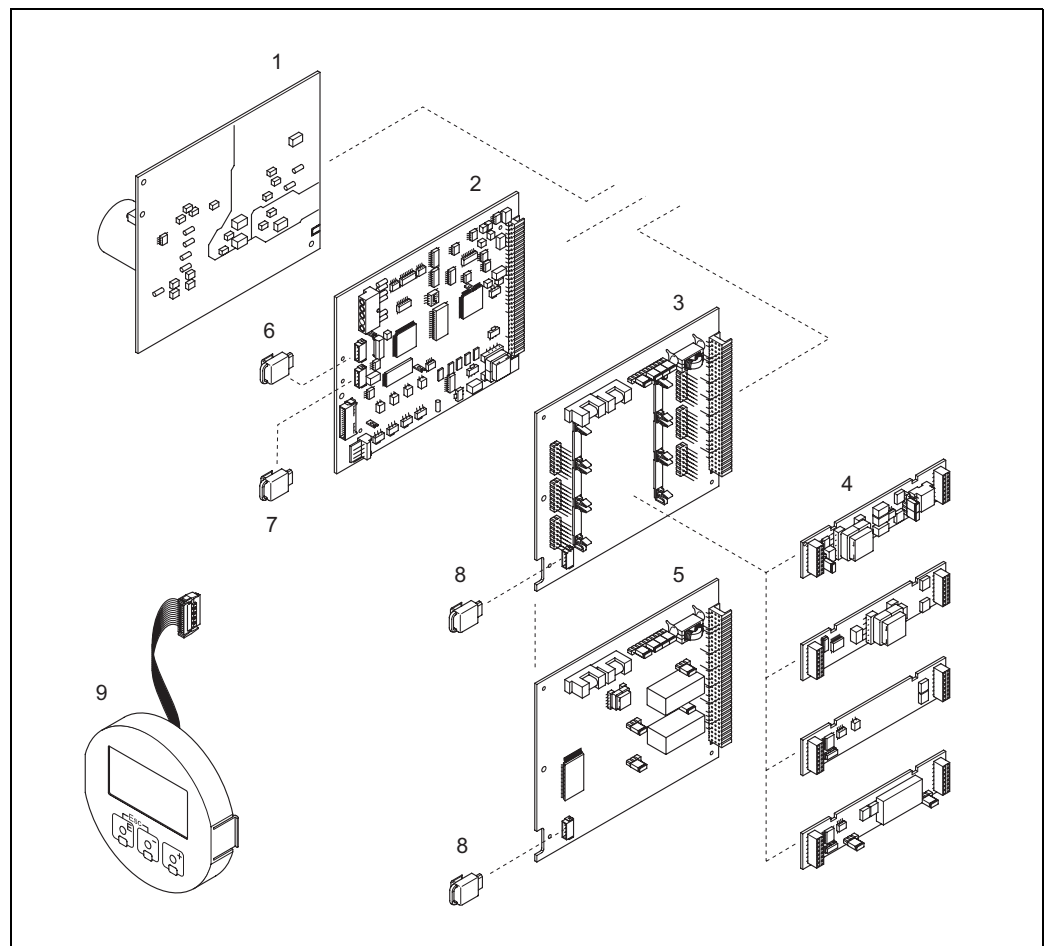

Fig. 57: Spare parts for Promag transmitter (field and wall-mount housing)

- 1 Power unit board
- 2 Amplifier board
- 3 I/O board (COM module), flexible assignment
- 4 Pluggable input/output submodules; product structure → [89](#)
- 5 I/O board (COM module), permanent assignment
- 6 S-DAT (sensor data storage device)
- 7 T-DAT (transmitter data storage device)
- 8 F-CHIP (function chip for optional software)
- 9 Display module

9.6.1 Removing and installing electronics boards

Field housing



Warning!

- Risk of electric shock. Exposed components carry dangerous voltages. Make sure that the power supply is switched off before you remove the cover of the electronics compartment.
- Risk of damaging electronic components (ESD protection). Static electricity can damage electronic components or impair their operability. Use a workplace with a grounded working surface purpose-built for electrostatically sensitive devices!
- If you cannot guarantee that the dielectric strength of the device is maintained in the following steps, then an appropriate inspection must be carried out in accordance with the manufacturer's specifications.



Caution!

Use only original Endress+Hauser parts.

Removing and installing the boards →  58:

1. Unscrew cover of the electronics compartment from the transmitter housing.
2. Remove the local display (1) as follows:
 - Press in the latches (1.1) at the side and remove the display module.
 - Disconnect the ribbon cable (1.2) of the display module from the amplifier board.
3. Remove the screws and remove the cover (2) from the electronics compartment.
4. Removing power unit board (4) and I/O board (6, 7):
 - Insert a thin pin into the hole provided (3) and pull the board clear of its holder.
5. Removing submodules (6.2, only for devices with flexibly assigned I/O board):
 - No additional tools are required for removing the submodules (inputs/outputs) from the I/O board or plugging them into it.



Caution!

Only certain combinations of submodules on the I/O board are permissible →  47.

The individual slots are marked and correspond to certain terminals in the connection compartment of the transmitter:

- Slot "INPUT/OUTPUT 2" = Terminals 24/25
- Slot "INPUT/OUTPUT 3" = Terminals 22/23
- Slot "INPUT/OUTPUT 4" = Terminals 20/21

6. Remove amplifier board (5):
 - Disconnect the plug of the electrode signal cable (5.1) including S-DAT (5.3) from the board.
 - Loosen the plug locking of the coil current cable (5.2) and gently disconnect the plug from the board, i.e. without moving it to and fro.
 - Insert a thin pin into the hole provided (3) and pull the board clear of its holder.
7. Installation is the reverse of the removal procedure.

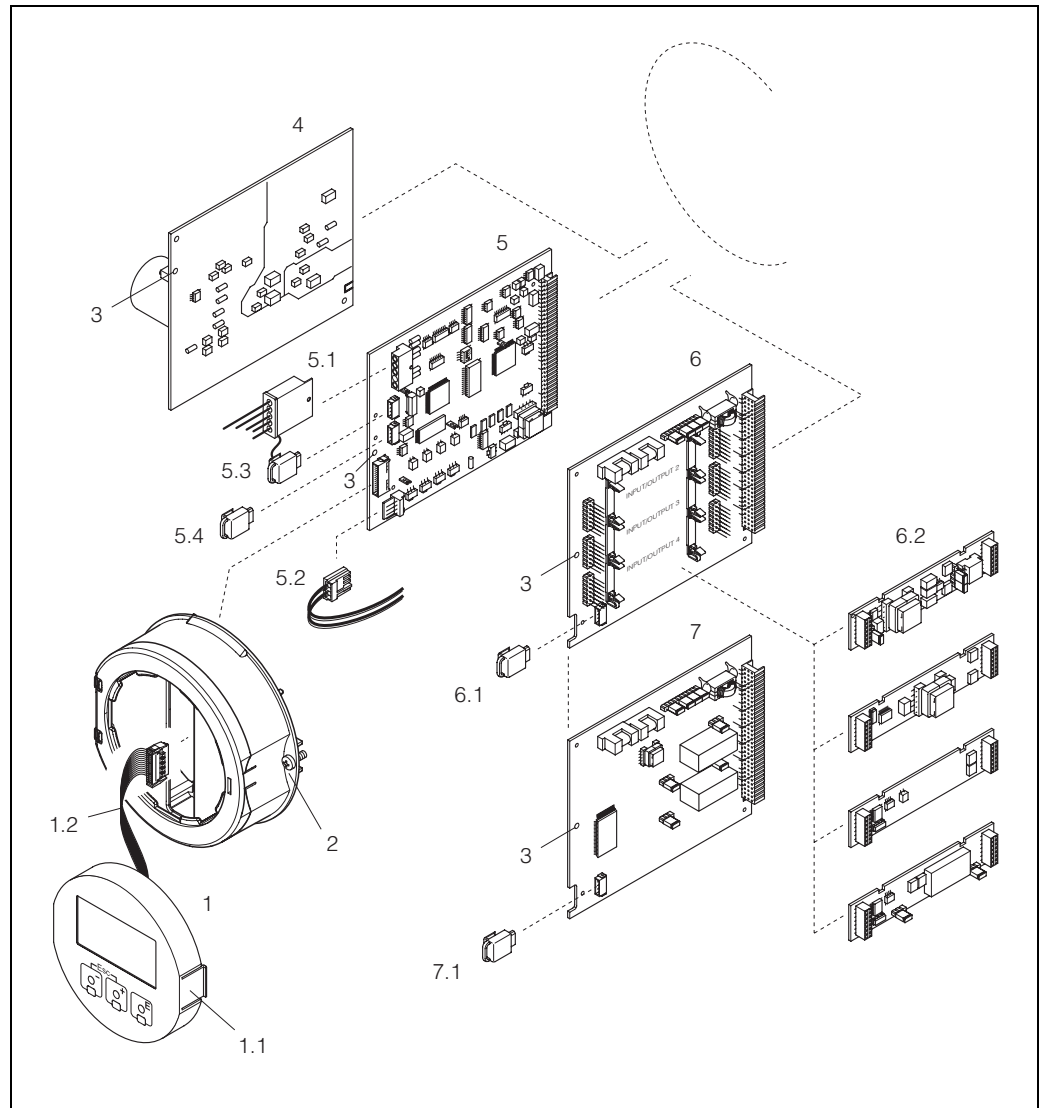

Fig. 58: Field housing: removing and installing printed circuit boards

- 1 Local display
- 1.1 Latch
- 1.2 Ribbon cable (display module)
- 2 Screws for electronics compartment cover
- 3 Aperture for installing / removing boards
- 4 Power unit board
- 5 Amplifier board
- 5.1 Electrode signal cable (sensor)
- 5.2 Coil current cable (sensor)
- 5.3 S-DAT (sensor data storage device)
- 5.4 T-DAT (transmitter data storage device)
- 6 I/O board (flexible assignment)
- 6.1 F-CHIP (function chip for optional software)
- 6.2 Pluggable submodules (inputs/outputs)
- 7 I/O boards (permanent assignment)
- 7.1 F-CHIP (function chip for optional software)

Wall-mount housing**Warning!**

- Risk of electric shock. Exposed components carry dangerous voltages. Make sure that the power supply is switched off before you remove the cover of the electronics compartment.
- Risk of damaging electronic components (ESD protection). Static electricity can damage electronic components or impair their operability. Use a workplace with a grounded working surface purpose-built for electrostatically sensitive devices!
- If you cannot guarantee that the dielectric strength of the device is maintained in the following steps, then an appropriate inspection must be carried out in accordance with the manufacturer's specifications.

**Caution!**

Use only original Endress+Hauser parts.

Installing and removing the boards →  105:

1. Remove the screws and open the hinged cover (1) of the housing.
2. Loosen the screws securing the electronics module (2). Then push up electronics module and pull it as far as possible out of the wall-mounted housing.
3. Disconnect the following cable plugs from amplifier board (7):
 - Electrode signal cable plug (7.1) including S-DAT (7.3)
 - Plug of coil current cable (7.2): To do so, loosen the plug locking of the coil current cable (5.2) and carefully disconnect the plug from the board, i.e. without moving it to and fro.
 - Ribbon cable plug (3) of the display module
4. Remove the cover (4) from the electronics compartment by loosening the screws.
5. Removing boards (6, 7, 8):
 - Insert a thin pin into the hole provided (5) and pull the board clear of its holder.
6. Removing submodules (8.2, only for devices with flexibly assigned I/O board):
 - No additional tools are required for removing the submodules (inputs/outputs) from the I/O board or plugging them into it.

**Caution!**

Only certain combinations of submodules on the I/O board are permissible →  47.

The individual slots are marked and correspond to certain terminals in the connection compartment of the transmitter:

- Slot "INPUT/OUTPUT 2" = Terminals 24/25
- Slot "INPUT/OUTPUT 3" = Terminals 22/23
- Slot "INPUT/OUTPUT 4" = Terminals 20/21

7. Installation is the reverse of the removal procedure.

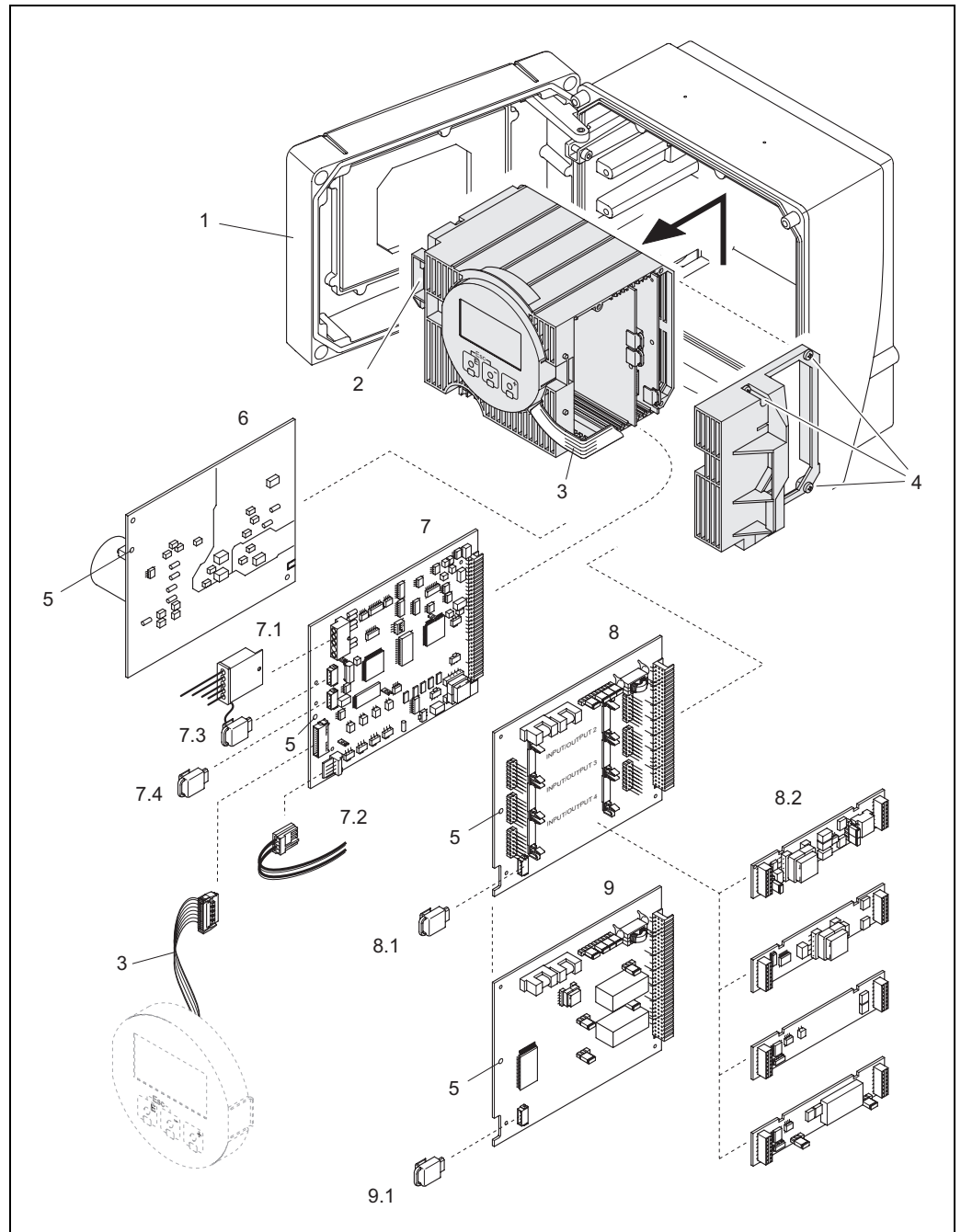

Fig. 59: Wall-mounted housing: removing and installing printed circuit boards

- 1 Housing cover
- 2 Electronics module
- 3 Ribbon cable (display module)
- 4 Screws for electronics compartment cover
- 5 Aperture for installing /removing boards
- 6 Power unit board
- 7 Amplifier board
- 7.1 Electrode signal cable (sensor)
- 7.2 Coil current cable (sensor)
- 7.3 S-DAT (sensor data storage device)
- 7.4 T-DAT (transmitter data storage device)
- 8 I/O board (flexible assignment)
- 8.1 F-CHIP (function chip for optional software)
- 8.2 Pluggable submodules (inputs/outputs)
- 9 I/O boards (permanent assignment)
- 9.1 F-CHIP (function chip for optional software)

9.6.2 Replacing the device fuse



Warning!

Risk of electric shock. Exposed components carry dangerous voltages. Make sure that the power supply is switched off before you remove the cover of the electronics compartment.

The main fuse is on the power supply board →  60.

The procedure for replacing the fuse is as follows:

1. Switch off power supply.
2. Remove power unit board →  102.
3. Remove cap (1) and replace the device fuse (2).
Use only the following types of fuses:
 - 85 to 260 V AC: 0.8 A slow-blow / 250 V
 - 20 to 55 V AC and 16 to 62 V DC: 2 A slow-blow / 250 V
 - Ex-rated devices → See the Ex documentation
4. Installation is the reverse of the removal procedure.



Caution!

Use only original Endress+Hauser parts.

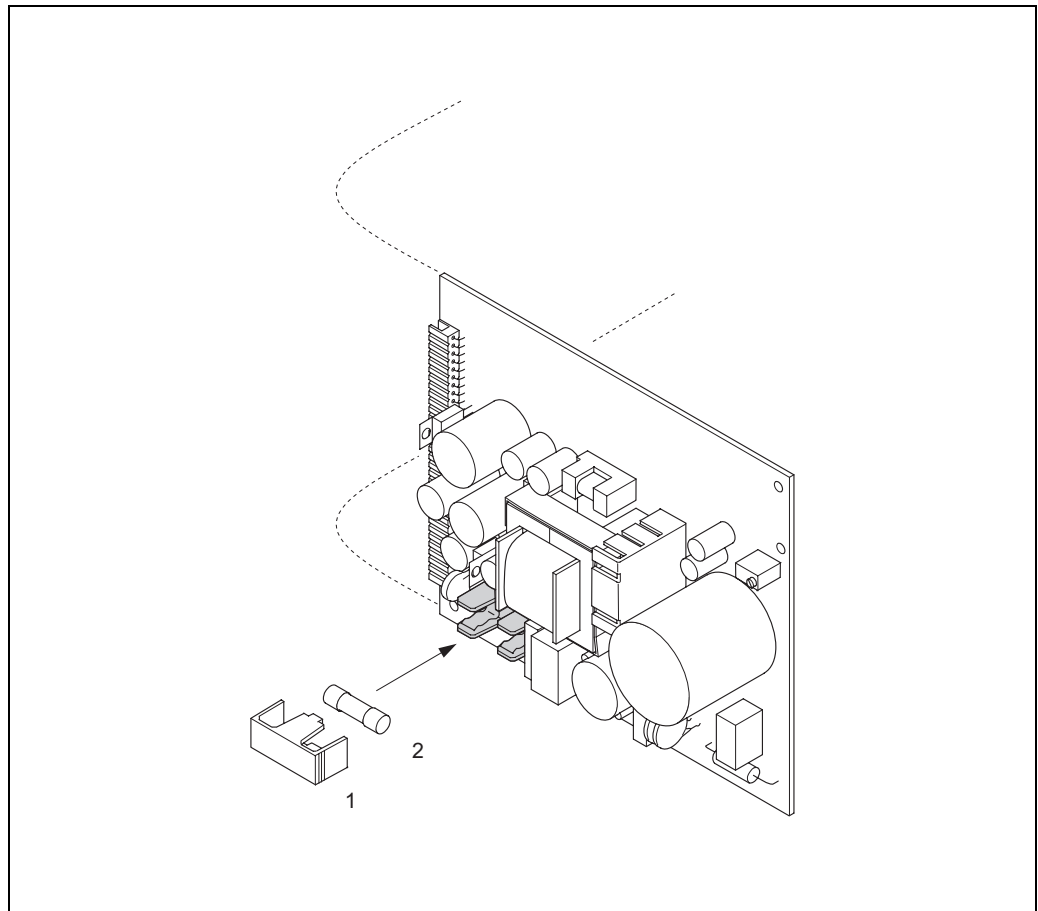

Fig. 60: Replacing the device fuse on the power supply board

- 1 Protection cap
- 2 Device fuse

9.6.3 Replacing the exchangeable electrode

The Promag W sensor (DN 350 to 2000; 14" to 78") can be supplied with optional exchangeable measuring electrodes. This design allows the measuring electrodes to be exchanged or cleaned under process conditions.

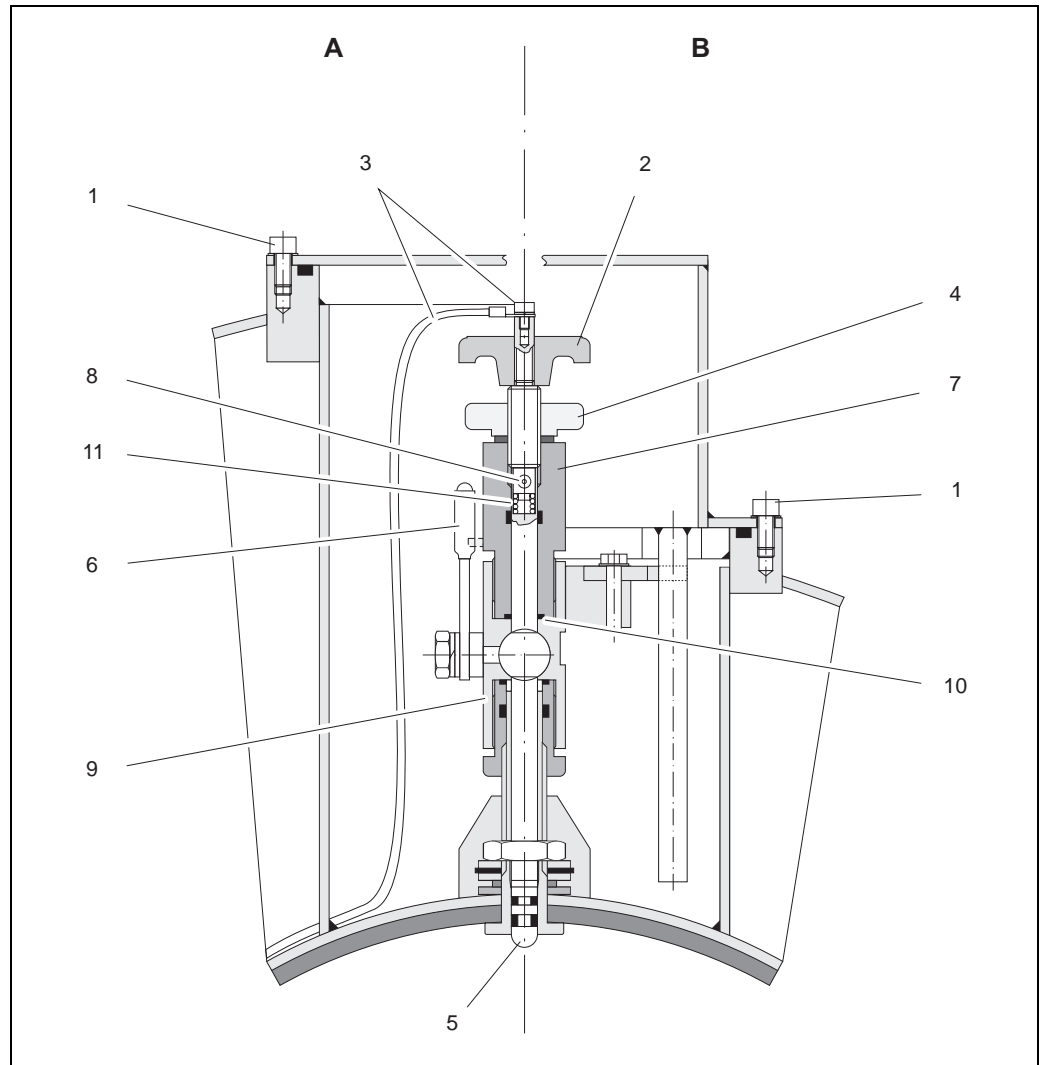







Fig. 61: Device for replacing the exchangeable measuring electrodes

View A = DN 1200 to 2000 (48" to 78")

View B = DN 350 to 1050 (14" to 42")

- 1 Socket head cap screw
- 2 Rotary handle
- 3 Electrode cable
- 4 Knurled nut (counter nut)
- 5 Measuring electrode
- 6 Stop cock (ball valve)
- 7 Retaining cylinder
- 8 Locking bolt (rotary handle)
- 9 Ball valve housing
- 10 Seal (retaining cylinder)
- 11 Coil spring

Removing the electrode	Fitting the electrode
<p>1 Release the socket head cap screw (1) and remove the cap.</p>	<p>1 Insert the new electrode (5) from underneath into the retaining cylinder (7). Ensure that the seals at the tip of the electrode are clean.</p>
<p>2 Unscrew the electrode cable (3) secured on the rotary handle (2).</p>	<p>2 Attach the rotary handle (2) to the electrode and secure with the locking bolt (8).  Caution! Ensure that the coil spring (11) is inserted to guarantee perfect electrical contact and thus correct measuring signals.</p>
<p>3 Release the knurled nut (4) by hand. This knurled nut serves as a counter nut.</p>	<p>3 Pull the electrode back until the tip is no longer protruding from the retaining cylinder (7).</p>
<p>4 Unscrew the electrode (5) using the rotary handle (2). It can now be pulled out of the retaining cylinder (7) up to a defined point.  Warning! Risk of injury! The electrode can bounce back to its stop under process conditions (pressure in the pipe). Exert counter pressure against it when releasing.</p>	<p>4 Screw the retaining cylinder (7) onto the ball valve housing (9) and secure tightly by hand. The seal (10) at the retaining cylinder must be fitted and clean.  Note! Ensure that the rubber hoses attached to the retaining cylinder (7) and stop cock (6) are the same color (red or blue).</p>
<p>5 Close the stop cock (6) after you have pulled out the electrode as far as it will go.  Warning! Do not open the stop cock after this to ensure that no fluid comes out.</p>	<p>5 Open the stop cock (6) and screw the electrode as far as it will go into the retaining cylinder using the rotary handle (2).</p>
<p>6 You can now unscrew the entire electrode with the retaining cylinder (7).</p>	<p>6 Now, screw the knurled nut (4) on the retaining cylinder. This secures the electrode in position.</p>
<p>7 Remove the rotary handle (2) from the electrode (5) by pushing out the locking bolt (8). Ensure that you do not lose the coil spring (11).</p>	<p>7 Secure the electrode cable (3) on the rotary handle (2) once more using the socket head cap screw.  Caution! Ensure that the socket head cap screw of the electrode cable is securely tightened. This guarantees perfect electrical contact and thus correct measuring signals.</p>
<p>8 Now replace the old electrode with the new one. You can order replacement electrodes separately from Endress+Hauser</p>	<p>8 Refit the cover and tighten the socket head cap screw (a).</p>

9.7 Return



Caution!

Do not return a measuring device if you are not absolutely certain that all traces of hazardous substances have been removed, e.g. substances which have penetrated crevices or diffused through plastic.

Costs incurred for waste disposal and injury (burns, etc.) due to inadequate cleaning will be charged to the owner-operator.

The following steps must be taken before returning a flow measuring device to Endress+Hauser, e.g. for repair or calibration:

- Always enclose a duly completed "Declaration of contamination" form. Only then can Endress+Hauser transport, examine and repair a returned device.
- Enclose special handling instructions if necessary, for example a safety data sheet as per EC REACH Regulation No. 1907/2006.
- Remove all residues. Pay special attention to the grooves for seals and crevices which could contain residues. This is particularly important if the substance is hazardous to health, e.g. flammable, toxic, caustic, carcinogenic, etc.



Note!

You will find a preprinted "Declaration of contamination" form at the back of these Operating Instructions.

9.8 Disposal

Please observe the regulations applicable in your country or region.

9.9 Software history

Date	Software-Version	Changes to software	Documentation
12.2009	2.02.XX	Introduction of Calf history	71107993/12.09
03.2005	2.00.XX	Software expansion: – Language group (contains the language Chinese and English) New functionalities: – DEVICE SOFTWARE → Device software displayed (NAMUR-recommendation 53) Unit US Kgal	50097083/03.05
11.2004	Amplifier: 1.06.01 Communication module: 1.04.00	Software update relevant only for production	50097083/10.03
10.2003	Amplifier: 1.06.00 Communication module: 1.03.00	Software expansion: – Language groups – Flow direction pulse output selectable New functionalities: – Second Totalizer – Adjustable backlight (display) – Operation hours counter – Simulation function for pulse output – Access code for counter – Reset function (fault history) – Up-/download with FieldTool	50097083/10.03

Date	Software-Version	Changes to software	Documentation
08.2003	Communication module: 1.02.01	Software expansion: – New / revised functionalities Special documentation: – Current span NAMUR NE 43 – Failsafe mode function – Trouble-shooting function – System and process error messages – Response of status output	50097083/08.03
08.2002	Amplifier: 1.04.00	Software expansion: – New / revised functionalities Special documentation: – Current span NAMUR NE 43 – Quick Setup "Batching" – EPD (new mode) – Failsafe mode function – Acknowledge fault function – Trouble-shooting function – Function "T-DAT SAVE/LOAD" – System and process error messages – Response of relay and status output	50097083/08.02
06.2001	Amplifier: 1.02.00 Communication module: 1.02.00	Software expansion: – New functionalities New functionalities: – Device functions in general – "Batching" software function – "OED" software function – "Advanced Diagnostics" software function – "Pulse width" software function	50097083/06.01
09.2000	Amplifier: 1.01.01 Communication module: 1.01.00	Software expansion: – Functional adaptations	none
08.2000	Amplifier: 1.01.00	Software expansion: – Functional adaptations	none
04.2000	Amplifier: 1.00.00 Communication module: 1.00.00	Original software. Compatible with: – FieldTool – Commuwin II (version 2.05.03 and higher) – HART Communicator DXR 375 (from OS 4.6) with Rev. 1, DD 1.	–

10 Technical data

10.1 Technical data at a glance

10.1.1 Application

→ 5

10.1.2 Function and system design

Measuring principle Electromagnetic flow measurement on the basis of Faraday's Law.

Measuring system → 7

10.1.3 Input

Measured variable Flow rate (proportional to induced voltage)

Measuring range Typical $v = 0.01$ to 10 m/s (0.03 to 33 ft/s) with the specified measuring accuracy

Operable flow range Over 1000 : 1

Input signal *Status input (auxiliary input):*
 $U = 3 \dots 30$ V DC, $R_i = 5$ k Ω , galvanically isolated
 Configurable for: totalizer(s) reset, positive zero return, error-message reset

Current input:

active/passive selectable, galvanically isolated, full scale value adjustable, resolution: 3 μ A, temperature coefficient: typically 0.005 % o.f.s./ $^{\circ}$ C; (0.003 % o.f.s./ $^{\circ}$ F)

- active: 4 to 20 mA, $R_i \geq 150$ Ω , $U_{out} = 24$ V DC, short-circuit proof
- passive: 0/4 to 20 mA, $R_i \leq 150$ Ω , $U_{max} = 30$ V DC

10.1.4 Output

Output signal *Current output:*
 active/passive selectable, galvanically isolated, time constant selectable (0.01 to 100 s), full scale value adjustable, temperature coefficient: typically 0.005% o.f.s./ $^{\circ}$ C (0.003 % o.f.s./ $^{\circ}$ F), resolution: 0.5 μ A

- active: 0/4 to 20 mA, $R_L < 700$ Ω (for HART: $R_L \geq 250$ Ω)
- passive: 4 to 20 mA; supply voltage V_S : 18 to 30 V DC; $R_i \geq 150$ Ω



Pulse / frequency output:

active/passive selectable (Ex i version passive only), galvanically isolated

- active: 24 V DC, 25 mA (max. 250 mA over 20 ms), $R_L > 100$ Ω
- passive: open collector, 30 V DC, 250 mA
- Frequency output: end frequency 2 to 10000 Hz ($f_{max} = 12500$ Hz), on/off ratio 1:1, pulse width max. 2 s
- Pulse output: pulse value and pulse polarity selectable, pulse width configurable (0.05 to 2000 ms)

Signal on alarm	<p><i>Current output:</i> Failsafe mode selectable (e.g. according to NAMUR recommendation NE 43)</p> <p><i>Pulse / frequency output:</i> Failsafe mode selectable</p> <p><i>Relay output:</i> "de-energized" in the event of a fault or power supply failure</p> <p>Details →  99</p>
Load	See "output signal"
Switching output	<p><i>Relay output:</i> Normally closed (NC or break) or normally open (NO or make) contacts available (default: relay 1 = NO, relay 2 = NC), max. 30 V / 0.5 A AC; 60 V / 0.1 A DC, galvanically isolated. Configurable for: error messages, empty pipe detection (EPD), direction of flow, limit values</p>
Low flow cutoff	Switch points for low flow cut off freely selectable.
Galvanic isolation	All circuits for inputs, outputs, and power supply are galvanically isolated from each other.

10.1.5 Power supply

Electrical connections	→  40
Supply voltage (power supply)	<ul style="list-style-type: none"> ■ 85 to 260 V AC, 45 to 65 Hz ■ 20 to 55 V AC, 45 to 65 Hz ■ 16 to 62 V DC
Cable entries	<p>Power supply and signal cable (inputs/outputs):</p> <ul style="list-style-type: none"> ■ Cable gland M20 × 1.5 (8 to 12 mm / 0.31 to 0.47 inch) ■ Cable gland sensor for armored cables M20 × 1.5 (9.5 to 16 mm / 0.37 to 0.63 inch) ■ Cable entries for thread ½" NPT, G ½" <p>Connecting cable for remote version:</p> <ul style="list-style-type: none"> ■ Cable gland M20 × 1.5 (8 to 12 mm / 0.31 to 0.47 inch) ■ Cable gland sensor for armored cables M20 × 1.5 (9.5 to 16 mm / 0.37 to 0.63 inch) ■ Cable entries for thread ½" NPT, G ½"
Cable specifications remote version	→  40
Power consumption	<p><i>Power consumption</i></p> <ul style="list-style-type: none"> ■ AC: <15 VA (including sensor) ■ DC: <15 W (including sensor) <p><i>Switch-on current</i></p> <ul style="list-style-type: none"> ■ Max. 3 A (<5 ms) at 260 V AC ■ Max. 13.5 A (<50 ms) at 24 V AC

Power supply failure Lasting min. 1 power cycle:
 ■ EEPROM or HistoROM/T-DAT saves measuring system data if power supply fails
 ■ HistoROM/S-DAT: exchangeable data storage device which stores sensor characteristic data (nominal diameter, serial number, calibration factor, zero point etc.)

Potential equalization → 49

10.1.6 Performance characteristics

Reference operating conditions To DIN EN 29104 and VDI/VDE 2641:
 ■ Fluid temperature: +28 °C ± 2 K
 ■ Ambient temperature: +22 °C ± 2 K
 ■ Warm-up time: 30 minutes

 Installation:
 ■ Inlet run >10 × DN
 ■ Outlet run > 5 × DN
 ■ Sensor and transmitter grounded.
 ■ Sensor centered relative to the pipe.

Maximum measured error Standard: ±0.2% o.r. ± 2 mm/s (o.r. = of reading)



Note!
 Supply-voltage fluctuations have no effect within the specified range.

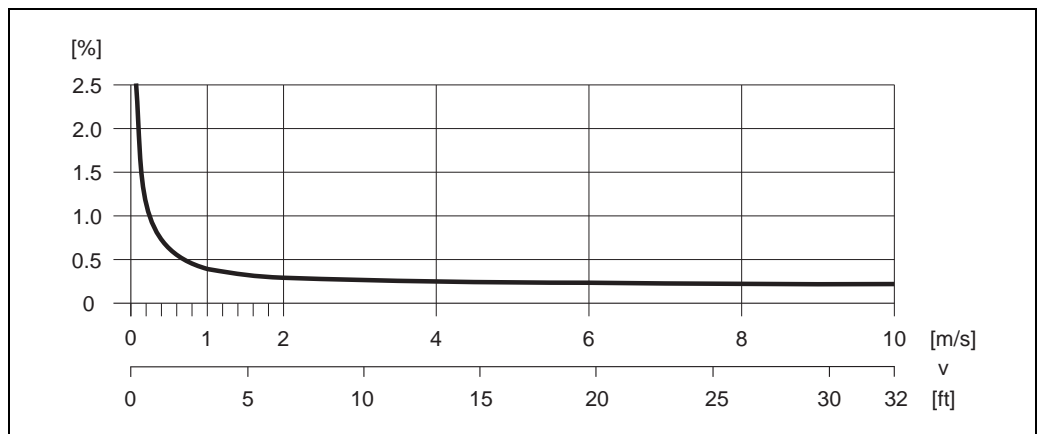

Fig. 62: Max. measured error in % of reading

Repeatability Standard: max. ±0.1% o.r. ± 0.5 mm/s (o.r. = of reading)

10.1.7 Operating conditions: Installation

Installation instructions →  13

Inlet and outlet runs
 Inlet run: typically $\geq 5 \times \text{DN}$
 Outlet run: typically $\geq 2 \times \text{DN}$

Length of connecting cable

- The permissible cable length L_{max} for the remote version depends on the conductivity of the medium →  20.
- A minimum conductivity of $20 \mu\text{S}/\text{cm}$ is required to measure demineralized water.

10.1.8 Operating conditions: Environment

Ambient temperature range

Transmitter:

- Standard: -20 to $+60 \text{ }^\circ\text{C}$ (-4 to $+140 \text{ }^\circ\text{F}$)
- Optional: -40 to $+60 \text{ }^\circ\text{C}$ (-40 to $+140 \text{ }^\circ\text{F}$)



Note!
 At ambient temperatures below $-20 \text{ }^\circ\text{C}$ ($-4 \text{ }^\circ\text{F}$), the readability of the display may be impaired.

Sensor:

- Flange material carbon steel: -10 to $+60 \text{ }^\circ\text{C}$ ($+14$ to $+140 \text{ }^\circ\text{F}$)
- Flange material stainless steel: -40 to $+60 \text{ }^\circ\text{C}$ (-40 to $+140 \text{ }^\circ\text{F}$)



Caution!
 Do not exceed the min. and max. temperatures for the lining of the measuring tube (→ "Medium temperature range").

Note the following points:

- Install the device at a shady location. Avoid direct sunlight, particularly in warm climatic regions.
- If both fluid and ambient temperatures are high, install the transmitter at a remote location from the sensor (→ "Medium temperature range").

Storage temperature

The storage temperature corresponds to the operating temperature range of the transmitter and sensor.



Caution!

- The measuring device must be protected against direct sunlight during storage in order to avoid unacceptably high surface temperatures.
- Choose a storage location where moisture does not collect in the measuring device. This will help prevent fungus and bacteria infestation which can damage the lining.

Degree of protection

- Standard: IP 67 (NEMA 4X) for transmitter and sensor
- Optional: IP 68 (NEMA 6P) for remote version of Promag W and Promag P sensors

Shock and vibration resistance

Acceleration up to 2 g in accordance with IEC 600 68-2-6
 (High-temperature version: no data available)

CIP cleaning



Caution!
 The maximum fluid temperature permitted for the measuring device must not be exceeded.

CIP cleaning possible:
 Promag P, Promag H

CIP cleaning not possible:
 Promag W

SIP cleaning



Caution!
 The maximum fluid temperature permitted for the measuring device must not be exceeded.

SIP cleaning possible:
 Promag P (with PFA lining), Promag H

SIP cleaning not possible:
 Promag W

Electromagnetic compatibility (EMC)

- As per IEC/EN 61326 and NAMUR Recommendation NE 21
- Emission: to limit value for industry EN 55011

10.1.9 Operating conditions: Process

Medium temperature range

The permitted temperature depends on the lining of the measuring tube:

Promag W

- 0 to +80 °C (+32 to +176 °F) for hard rubber (DN 65 to 2000 / 2½ to 80")
- -20 to +50 °C (-4 to +122 °F) for polyurethane (DN 25 to 1200 / 1 to 48")

Promag P

Standard

- -40 to +130 °C (-40 to +266 °F) for PTFE (DN 15 to 600 / ½ to 24"), restrictions → see diagrams below
- -20 to +130 °C (-4 to +266 °F) for PFA/HE (DN 25 to 200 / 1" to 8"), restrictions → see diagrams below
- -20 to +150 °C (-4 to +302 °F) for PFA (DN 25 to 200 / 1" to 8"), restrictions → see diagrams below

Optional

High-temperature version (HT): -20 to +180 °C (-4 to +356 °F) for PFA (DN 25 to 200 / 1" to 8")

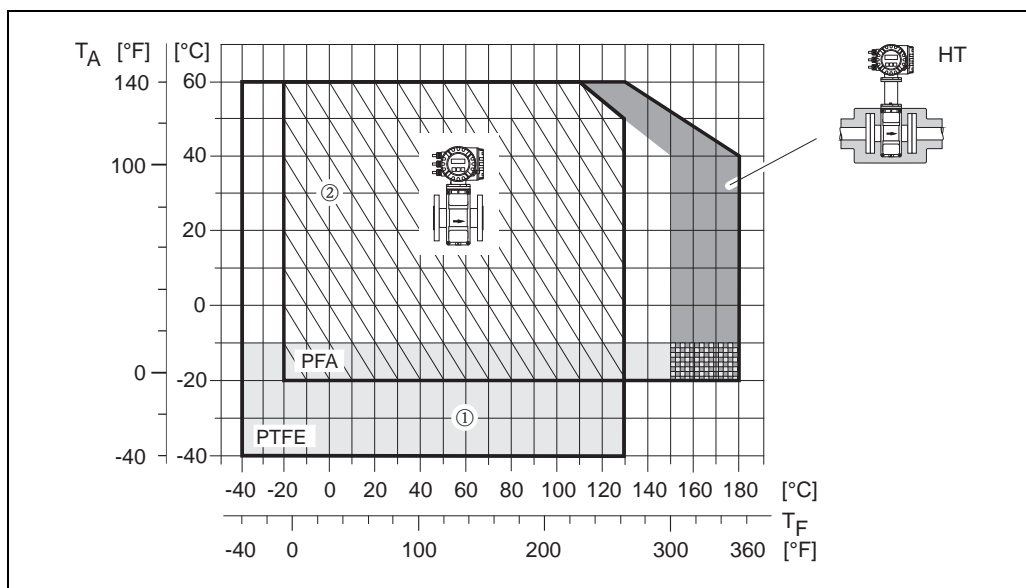

Fig. 63: Promag P compact version (with PFA or PTFE lining)

T_A = ambient temperature; T_F = fluid temperature; HT = high-temperature version with insulation
 ① = Light gray area → temperature range from -10 to -40 °C (-14 to -40 °F) applies only to stainless steel flanges
 ② = Diagonally hatched area → foam lining (HE) + degree of protection IP68 = fluid temperature max. 130°C / 266 °F

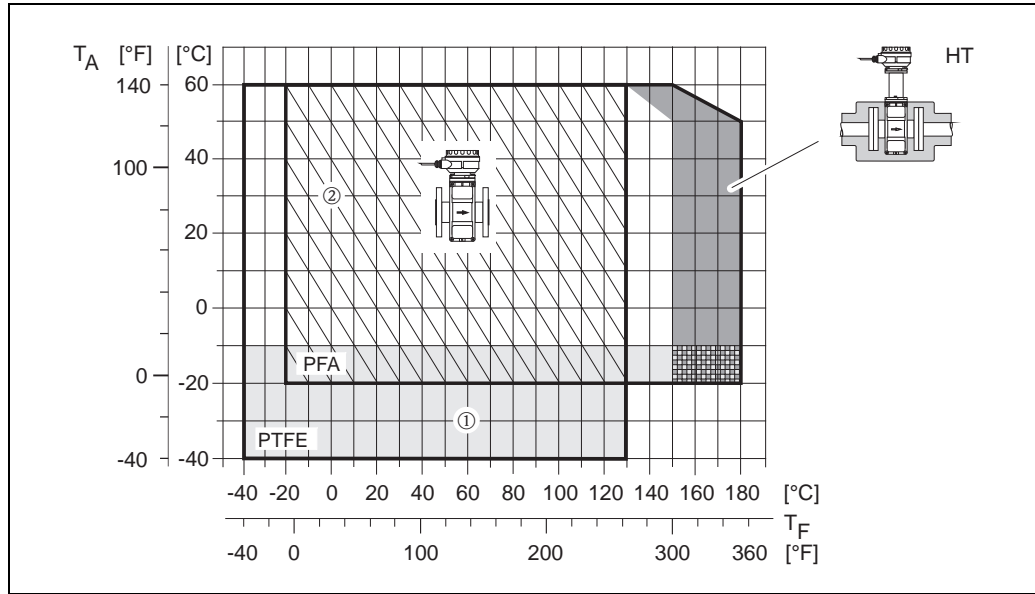

Fig. 64: Remote versions (with PFA or PTFE lining)

T_A = ambient temperature; T_F = fluid temperature; HT = high-temperature version with insulation

① = Light gray area → temperature range from -10 to -40 °C (-14 to -40 °F) applies only to stainless steel flanges

② = Diagonally hatched area → foam lining (HE) + degree of protection IP68 = fluid temperature max. 130 °C / 266 °F

Promag H

Sensor:

- DN 2 to 25: -20 to $+150$ °C (-4 to $+302$ °F)
- DN 40 to 100: -20 to $+150$ °C (-4 to $+302$ °F)

Seals:

- EPDM: -20 to $+150$ °C (-4 to $+302$ °F)
- Silicone: -20 to $+150$ °C (-4 to $+302$ °F)
- Viton: -20 to $+150$ °C (-4 to $+302$ °F)
- Kalrez: -20 to $+150$ °C (-4 to $+302$ °F)

Conductivity of the fluid



The minimum conductivity is ≥ 5 $\mu\text{S}/\text{cm}$ (for demineralized water ≥ 20 $\mu\text{S}/\text{cm}$)

Note!

In the remote version, the required minimum conductivity is also influenced by the length of the connecting cable → 20.

Limiting medium pressure range (nominal pressure)

Promag W

- EN 1092-1 (DIN 2501)
 - PN 6 (DN 350 to 2000)
 - PN 10 (DN 200 to 2000)
 - PN 16 (DN 65 to 2000)
 - PN 25 (DN 200 to 1000)
 - PN 40 (DN 25 to 150)
- ANSI B 16.5
 - Class 150 (1" to 24")
 - Class 300 (1" to 6")
- AWWA
 - Class D (28" to 78")
- JIS B2220
 - 10 K (DN 50 to 300)
 - 20 K (DN 25 to 300)
- AS 2129
 - Table E (DN 80, 100, 150 to 1200)

- AS 4087
 - PN 16 (DN 80, 100, 150 to 1200)

Promag P

- EN 1092-1 (DIN 2501)
 - PN 10 (DN 200 to 600)
 - PN 16 (DN 65 to 600)
 - PN 25 (DN 200 to 600)
 - PN 40 (DN 15 to 150)
- ANSI B 16.5
 - Class 150 (½" to 24")
 - Class 300 (½" to 6")
- JIS B2220
 - 10 K (DN 50 to 300)
 - 20 K (DN 15 to 300)
- AS 2129
 - Table E (DN 25, 50)
- AS 4087
 - PN 16 (DN 50)

Promag H

The permitted nominal pressure depends on the process connection and the seal:

- 40 bar → flange, weld nipple (with O-ring seal)
- 16 bar → all other process connections

Pressure tightness (measuring tube lining)

Promag W

Promag W nominal diameter		Measuring tube lining	Resistance of measuring tube lining to partial vacuum: limit values for absolute pressure [mbar] ([psi]) at various fluid temperatures						
[mm]	[inch]		25 °C 77 °F	50 °C 122 °F	80 °C 176 °F	100 °C 212 °F	130 °C 266 °F	150 °C 302 °F	180 °C 356 °F
25 to 1200	1 to 48"	Polyurethane	0	0	–	–	–	–	–
65 to 2000	3 to 78"	Hard rubber	0	0	0	–	–	–	–

Promag P

Measuring tube lining: PFA

Promag P nominal diameter		Resistance of measuring tube lining to partial vacuum: limit values for absolute pressure [mbar] ([psi]) at various fluid temperatures					
[mm]	[inch]	25 °C 77 °F	80 °C 176 °F	100 °C 212 °F	130 °C 266 °F	150 °C 302 °F	180 °C 356 °F
25	1"	0	0	0	0	0	0
32	–	0	0	0	0	0	0
40	1 ½"	0	0	0	0	0	0
50	2"	0	0	0	0	0	0
65	–	0	*	0	0	0	0
80	3"	0	*	0	0	0	0
100	4"	0	*	0	0	0	0
125	–	0	*	0	0	0	0
150	6"	0	*	0	0	0	0
200	8"	0	*	0	0	0	0

* No value can be quoted.

Promag P
 Measuring tube lining: PTFE

Promag P nominal diameter		Resistance of measuring tube lining to partial vacuum: limit values for absolute pressure [mbar] ([psi]) at various fluid temperatures								
[mm]	[inch]	25 °C		80 °C	100 °C		130 °C		150 °C	180 °C
		77 °F		176 °F	212 °F		266 °F		302 °F	356 °F
		[mbar]	[psi]		[mbar]	[psi]	[mbar]	[psi]		
15	½"	0	0	0	0	0	100	1,45	–	–
25	1"	0	0	0	0	0	100	1,45	–	–
32	–	0	0	0	0	0	100	1,45	–	–
40	1 ½"	0	0	0	0	0	100	1,45	–	–
50	2"	0	0	0	0	0	100	1,45	–	–
65	–	0	0	*	40	0,58	130	1,89	–	–
80	3"	0	0	*	40	0,58	130	1,89	–	–
100	4"	0	0	*	135	1,96	170	2,47	–	–
125	–	135	1,96	*	240	3,48	385	5,58	–	–
150	6"	135	1,96	*	240	3,48	385	5,58	–	–
200	8"	200	2,90	*	290	4,21	410	5,95	–	–
250	10"	330	4,79	*	400	5,80	530	7,69	–	–
300	12"	400	5,80	*	500	7,25	630	9,14	–	–
350	14"	470	6,82	*	600	8,70	730	10,59	–	–
400	16"	540	7,83	*	670	9,72	800	11,60	–	–
450	18"	Partial vacuum is impermissible								
500	20"									
600	24"									

* No value can be quoted.

Promag H (measuring tube lining: PFA)

Promag H nominal diameter		Pressure tightness, measuring tube lining: limit values for absolute pressure [mbar] ([psi]) at various fluid temperature					
[mm]	[inch]	25 °C	80 °C	100 °C	130 °C	150 °C	180 °C
		77 °F	176 °F	212 °F	266 °F	302 °F	356 °F
2 to 100	1/12 to 4"	0	0	0	0	0	0

Limiting flow

Further information can be found in the "Nominal diameter and flow rate" → 18 section

Pressure loss

- No pressure loss if the sensor is installed in piping with the same nominal diameter (for Promag H only from DN8).
- Pressure losses for configurations incorporating adapters according to DIN EN 545 → 17.

10.1.10 Mechanical construction

Design / dimensions

The dimensions and face-to-face length of the sensor and transmitter can be found in the separate "Technical Information" documentation for each device which can be downloaded in PDF format from www.endress.com. A list of available "Technical Information" documentation can be found in the "Documentation" →  128 section.

Weight (SI units)

Promag W

Note!

The following weights apply to standard pressure ratings and without packaging material.

Nominal diameter [mm]	Weights in [kg] for the Promag W								
	Compact version			Remote version (without cable)					
	EN (DIN) / AS*		JIS	Sensor		Transmitter			
	EN (DIN) / AS*	JIS	EN (DIN) / AS*	JIS					
25	PN 40	7.3	10K	7.3	PN 40	5.3	10K	5.3	6.0
32		8.0		7.3		6.0		5.3	6.0
40		9.4		8.3		7.4		6.3	6.0
50		10.6		9.3		8.6		7.3	6.0
65	PN 16	12.0	10K	11.1	PN 16	10.0	10K	9.1	6.0
80		14.0		12.5		12.0		10.5	6.0
100		16.0		14.7		14.0		12.7	6.0
125		21.5		21.0		19.5		19.0	6.0
150	PN 10	25.5	10K	24.5	PN 10	23.5	10K	22.5	6.0
200		45		41.9		43		39.9	6.0
250		65		69.4		63		67.4	6.0
300		70		72.3		68		70.3	6.0
350	PN 10	115	10K	113	PN 10	113	10K	6.0	6.0
375		134		133		133		6.0	6.0
400		135		173		173		6.0	6.0
450		175		173		173		6.0	6.0
500		175		233		233		6.0	6.0
600		235		353		353		6.0	6.0
700		355		433		433		6.0	6.0
800		435		573		573		6.0	6.0
900		575		698		698		6.0	6.0
1000		700		848		848		6.0	6.0
1200	PN 6	850	10K	1298	PN 6	1298	10K	6.0	6.0
1400		1300		1698		1698		6.0	6.0
1600		1700		2198		2198		6.0	6.0
1800		2200		2798		2798		6.0	6.0
2000	2800							6.0	6.0

Promag transmitter (compact version): 3.4 kg
 *Only DN 80, 100, 150 to 400, 500 and 600 are available for flanges as per AS

Promag P



Note!

The following weights apply to standard pressure ratings and without packaging material.

Nominal diameter	Weights in [kg] for the Promag P								
	Compact version			Remote version (without cable)					
	[mm]	EN (DIN) / AS*	JIS	Sensor		Transmitter			
EN (DIN) / AS*				JIS					
15	PN 40	6.5	10K	6.5	PN 40	4.5	10K	4.5	6.0
25		7.3		7.3		5.3		5.3	6.0
32		8.0		7.3		6.0		5.3	6.0
40		9.4		8.3		7.4		6.3	6.0
50		10.6		9.3		8.6		7.3	6.0
65	PN 16	12.0	10K	11.1	PN 16	10.0	10K	9.1	6.0
80		14.0		12.5		12.0		10.5	6.0
100		14.4		14.7		14.0		12.7	6.0
125		16.0		21.0		19.5		19.0	6.0
150		21.5		24.5		23.5		22.5	6.0
200	PN 10	45	10K	41.9	PN 10	43	10K	39.9	6.0
250		65		69.4		63		67.4	6.0
300		70		72.3		68		70.3	6.0
350		115				113			6.0
400		135				133			6.0
450	175		173		6.0				
500	175		173		6.0				
600	235		233		6.0				

Promag transmitter (compact version): 3.4 kg
 High-temperature version: +1.5 kg
 * Only DN 25 and 50 are available for flanges as per AS

Promag H



Note!

The following weights apply to standard pressure ratings and without packaging material.

Nominal diameter	Weights in [kg] for the Promag H			
	DIN	Compact version	Remote version (without cable)	
			Sensor	Transmitter
[mm]				
2		5.2	2.0	6.0
4		5.2	2.0	6.0
8		5.3	2.0	6.0
15		5.4	1.9	6.0
25		5.5	2.8	6.0
40		6.5	4.5	6.0
50		9.0	7.0	6.0
65		9.5	7.5	6.0
80		19.0	17.0	6.0
100		18.5	16.5	6.0

Promag transmitter (compact version): 3.4 kg

Weight (US units)

Promag W



Note!

The following weights apply to standard pressure ratings and without packaging material.

Nominal diameter [inch]	Weights in [lbs] for the Promag W				
	Compact version		Remote version (without cable)		
	ANSI/AWWA		Sensor ANSI/AWWA	Transmitter	
1"	Class 150	16	Class 150	12	13
1 1/2"		21		16	13
2"		23		19	13
3"		31		26	13
4"		35		31	13
6"		56		52	13
8"		99		95	13
10"		143		161	13
12"		243		238	13
14"		386		381	13
16"		452		448	13
18"		562		558	13
20"		628		624	13
24"		893		889	13
28"		Class D		882	Class D
30"	1014		1010	13	
32"	1213		1208	13	
36"	1764		1760	13	
40"	1985		1980	13	
42"	2426		2421	13	
48"	3087		3083	13	
54"	4851		4847	13	
60"	5954		5949	13	
66"	8159		8154	13	
72"	9041	9036	13		
78"	10143	10139	13		

Promag transmitter (compact version): 7.5 lbs

Promag P



Note!

The following weights apply to standard pressure ratings and without packaging material.

Nominal diameter [inch]	Weights in [lbs] for the Promag P				
	Compact version		Remote version (without cable)		
	ANSI/AWWA		Sensor ANSI/AWWA	Transmitter	
½"	Class 150	14	Class 150	10	13
1"		16		12	13
1 ½"		21		16	13
2"		23		19	13
3"		31		26	13
4"		35		31	13
6"		56		52	13
8"		99		95	13
10"		165		161	13
12"		243		238	13
14"		386		381	13
16"		452		448	13
18"		562		558	13
20"		628		624	13
24"		893		889	13

Promag transmitter (compact version): 7.5 lbs
High-temperature version: + 3.3 lbs

Promag H



Note!

The following weights apply to standard pressure ratings and without packaging material.

Nominal diameter [inch]	Weights in [lbs] for the Promag H		
	Compact version	Remote version (without cable)	
		Sensor	Transmitter
1/12"	11.5	4.4	13.5
5/32"	11.5	4.4	13.5
5/16"	11.7	4.4	13.5
½"	11.9	4.2	13.5
1"	12.1	6.2	13.5
1 ½"	14.3	9.9	13.2
2"	19.8	15.5	13.2
3"	41.9	37.5	13.2
4"	40.8	36.5	13.2

Promag transmitter (compact version): 7.5 lbs

Material

Promag W

- Transmitter housing:
 - Housing for compact version: powder-coated die-cast aluminum
 - Wall-mount housing: powder-coated die-cast aluminum
- Sensor housing
 - DN 25 to 300: powder-coated die-cast aluminum
 - DN 350 to 2000: with protective coating
- Measuring tube
 - DN ≤ 300: stainless steel 1.4301 or 1.4306/304L
for flanges made of carbon steel with Al/Zn protective coating
 - DN ≥ 350: stainless steel 1.4301 or 1.4306/304
for flanges made of carbon steel with protective coating
- Electrodes: 1.4435, Alloy C-22, tantalum
- Flanges
 - EN 1092-1 (DIN2501): 1.4571/316L; RSt37-2 (S235JRG2); C22; FE 410W B
(DN ≤ 300: with Al/Zn protective coating; DN ≥ 350 with protective coating)
 - ANSI: A105; F316L
(DN ≤ 300 with Al/Zn protective coating; DN ≥ 350 with protective coating)
 - AWWA: 1.0425
 - JIS: RSt37-2 (S235JRG2); HII; 1.0425/316L
(DN ≤ 300 with Al/Zn protective coating; DN ≥ 350 with protective coating)
 - AS 2129
 - (DN 150, 200, 250, 300, 600) A105 or RSt37-2 (S235JRG2)
 - (DN 80, 100, 350, 400, 500) A105 or St44-2 (S275JR)
 - AS 4087: A105 or St44-2 (S275JR)
- Seals: as per DIN EN 1514-1
- Ground disks: 1.4435/316L, Alloy C-22, titanium, tantalum

Promag P

- Transmitter housing:
 - Compact housing: powder-coated die-cast aluminum
 - Wall-mount housing: powder-coated die-cast aluminum
- Sensor housing
 - DN 15 to 300: powder-coated die-cast aluminum
 - DN 350 to 2000: with protective coating
- Measuring tube
 - DN ≤ 300: stainless steel 1.4301 or 1.4306/304L
for flanges made of carbon steel with protective coating
 - DN ≥ 350: stainless steel 1.4301 or 1.4306/304
for flanges made of carbon steel with protective coating
- Electrodes: 1.4435; Alloy C-22; titanium; tantalum; platinum
- Flanges
 - EN 1092-1 (DIN2501): 1.4571/316L; RSt37-2 (S235JRG2); C22; FE 410W B
(DN ≤ 300: with Al/Zn protective coating; DN ≥ 350 with protective coating)
 - ANSI: A105; F316L
(DN ≤ 300 with Al/Zn protective coating; DN ≥ 350 with protective coating)
 - AWWA: 1.0425
 - JIS: RSt37-2 (S235JRG2); HII; 1.0425/316L
(DN ≤ 300 with Al/Zn protective coating; DN ≥ 350 with protective coating)
 - AS 2129
 - (DN 25) A105 or RSt37-2 (S235JRG2)
 - (DN 40) A105 or St44-2 (S275JR)
 - AS 4087: A105 or St44-2 (S275JR)

- Seals: as per DIN EN 1514-1
- Ground disks: 1.4435/316L, Alloy C-22, titanium, tantalum

Promag H

Transmitter housing:

- Compact housing: powder-coated die-cast aluminum or stainless steel field housing (1.4301/316L)
- Wall-mount housing: powder-coated die-cast aluminum
- Window material: glass or polycarbonate
- Sensor housing: stainless steel 1.4301
- Wall mounting kit (holder panel): stainless steel 1.4301
- Measuring tube: stainless steel 1.4301

Flanges:

- Connection generally made of stainless steel 1.4404/316L
- Flanges (EN (DIN), ANSI, JIS) also in PVDF
- Adhesive fitting made of PVC

Electrodes:

- Standard: 1.4435
- Optional: Alloy C-22, tantalum, platinum (only up to DN 25 (1"))

Seals:

- DN 2 to 25: O-ring (EPDM, Viton, Kalrez) or molded seal (EPDM, silicone, Viton)
- DN 40 to 100: molded seal (EPDM, silicone)

Grounding rings:

- Standard: 1.4435/316L,
- Optional: Alloy C-22, tantalum

Material load diagrams

The material load diagrams (pressure-temperature diagrams) for the process connections can be found in the separate "Technical Information" documentation, which you can download in PDF format from www.endress.com.
A list of available "Technical Information" documentation can be found in the "Documentation" →  128 section.

Fitted electrodes

Promag W

Available as standard:

- 2 measuring electrodes for signal detection
- 1 EPD electrode for empty pipe detection
- 1 Reference electrode for potential equalization

Optionally available:

- Exchangeable measuring electrodes for DN 350 to 2000 (14" to 78")

Promag P

Available as standard:

- 2 measuring electrodes for signal detection
- 1 EPD electrode for empty pipe detection
- 1 Reference electrode for potential equalization

Optionally available:

- Platinum measuring electrodes only

Promag H

- 2 measuring electrodes for signal detection
- 1 EPD electrode for empty pipe detection, not for DN 2 to 15 (1/12" to 1/2")

Process connection	<p><i>Promag W and Promag P</i></p> <p>Flange connections:</p> <ul style="list-style-type: none"> ■ EN 1092-1 (DIN 2501) <ul style="list-style-type: none"> – DN ≤ 300 = form A – DN ≥ 350 = form B – DN 65 PN 16 and DN 600 PN 16 exclusively according to EN 1092-1 ■ ANSI ■ AWWA (Promag W only) ■ JIS ■ AS <p><i>Promag H</i></p> <p>With O-ring:</p> <ul style="list-style-type: none"> ■ Weld nipple DIN (EN), ISO 1127, ODT/SMS ■ Flange EN (DIN), ANSI, JIS ■ Flange made of PVDF EN (DIN), ANSI, JIS ■ External thread ■ Internal thread ■ Hose connection ■ PVC adhesive fitting <p>With molded seal:</p> <ul style="list-style-type: none"> ■ Weld nipple DIN 11850, ODT/SMS ■ Clamp ISO 2852, DIN 32676, L14 AM7 ■ Coupling DIN 11851, DIN 11864-1, ISO 2853, SMS 1145 ■ Flange DIN 11864-2
Surface roughness	<p>All data relate to parts in contact with fluid.</p> <ul style="list-style-type: none"> ■ Liner → PFA: ≤ 0.4 μm (15 μin) ■ Electrodes: 0.3 to 0.5 μm (12 to 20 μin) ■ Process connection made of stainless-steel (Promag H): ≤ 0.8 μm (31 μin)

10.1.11 Human interface

Display elements	<ul style="list-style-type: none"> ■ Liquid crystal display: illuminated, four lines with 16 characters per line ■ Custom configurations for presenting different measured values and status variables ■ 3 totalizers ■ At ambient temperatures below $-20\text{ }^{\circ}\text{C}$ ($-4\text{ }^{\circ}\text{F}$), the readability of the display may be impaired.
Operating elements	<ul style="list-style-type: none"> ■ Onsite operation with three optical sensor keys ([-]/[+]/[E]) ■ Application-specific Quick Setup menus for straightforward commissioning
Language groups	<p>Language groups available for operation in different countries:</p> <ul style="list-style-type: none"> ■ Western Europe and America (WEA): English, German, Spanish, Italian, French, Dutch, Portuguese ■ Eastern Europe/Scandinavia (EES): English, Russian, Polish, Norwegian, Finnish, Swedish, Czech ■ South and East Asia (SEA): English, Japanese, Indonesian ■ China (CN): English, Chinese <p> Note! The language group is changed in the "FieldCare" operating program.</p>
Remote operation	Operation by means of HART protocol

10.1.12 Certificates and approvals

CE mark	The measuring system complies with the legal requirements of the EU directives. Endress+Hauser confirms that the device has been tested successfully by affixing the CE mark to it.
C-tick mark	The measuring system is in conformity with the EMC requirements of the "Australian Communications and Media Authority (ACMA)".
Ex approval	Information about currently available Ex versions (ATEX, FM, CSA, TIIS, IECEx, NEPSI etc.) can be supplied by your Endress+Hauser Sales Center on request. All explosion protection data are given in a separate documentation which is available upon request.
Sanitary compatibility	<p><i>Promag W and Promag P</i> No applicable approvals or certification</p> <p><i>Promag H</i></p> <ul style="list-style-type: none"> ■ 3A-approval and EHEDG-tested ■ Seals: FDA-compliant (except for Kalrez seals)
Drinking water approval	<p><i>Promag W</i></p> <ul style="list-style-type: none"> ■ WRAS BS 6920 ■ ACS ■ NSF 61 ■ KTW/W270 <p><i>Promag P</i></p> <ul style="list-style-type: none"> ■ ACS

Pressure measuring device approval	Measuring devices with a nominal diameter smaller than or equal to DN 25, correspond to Article 3(3) of the EC Directive 97/23/EC (Pressure Equipment Directive) and have been designed and manufactured according to good engineering practice. For larger nominal diameters, (depending on the medium and process pressure), there are additional optional approvals according to category II/III.
Other standards and guidelines	<ul style="list-style-type: none">■ EN 60529: Degrees of protection by housing (IP code)■ EN 61010-1 Protection measures for electrical equipment for measurement, control, regulation and laboratory procedures■ IEC/EN 61326 "Emission in accordance with requirements for class A". Electromagnetic compatibility (EMC requirements).■ ANSI/ISA-S82.01 Safety Standard for Electrical and Electronic Test, Measuring, Controlling and related Equipment - General Requirements. Pollution degree 2, Installation Category II.■ CAN/CSA-C22.2 (No. 1010.1-92) Safety requirements for Electrical Equipment for Measurement and Control and Laboratory Use. Pollution degree 2, Installation Category I.■ NAMUR NE 21 Electromagnetic compatibility (EMC) of industrial process and laboratory control equipment.■ NAMUR NE 43 Standardization of the signal level for the breakdown information of digital transmitters with analog output signal.■ NAMUR NE 53 Software of field devices and signal-processing devices with digital electronics.

10.1.13 Ordering information

The Endress+Hauser service organization can provide detailed information on the order codes on request.

10.1.14 Accessories

Various accessories are available for the transmitter and the sensor. These can be ordered separately from Endress+Hauser →  89.



Note!

For detailed information on specific order codes, please contact the Endress+Hauser service organization.

10.1.15 Documentation

- Flow Measurement (FA005D/06)
- Promag 53W Technical Information (TI046D/06)
- Promag 53P Technical Information (TI047D/06)
- Promag 53H Technical Information (TI048D/06)
- Promag 53 Description of Device Functions (BA048D/06)
- Supplementary documentation on Ex-ratings: ATEX, FM, CSA

Index

A

- Accessories 89
- Adapters (installation of sensors) 17
- Ambient temperature range 114
- Applicator (selection and configuration software) 91
- Approvals 10
- Auxiliary input
 - See Status input

B

- Batching 56
 - Quick Setup 78
- Boards
 - See Printed circuit boards

C

- Cable entries
 - Degree of protection 51
 - Technical data 112
- Cable length (remote version) 20
- Cable specifications 44
- Cable specifications (remote version)
 - Cable length, conductivity 20
- Calibration factor 8
- CE mark 126
- CE mark (Declaration of Conformity) 10
- Certificates 10
- Change parameter / enter numerical values 57
- CIP cleaning 114
- Cleaning (exterior cleaning) 88
- Cleaning using pigs, Promag H 34
- Code entry (function matrix) 58
- Commissioning
 - "Commissioning" Quick Setup menu 74
 - "Pulsating flow" Quick Setup menu 75
 - Configuring current input (active/passive) 84
 - Configuring current outputs (active/passive) 82
 - Configuring relay contacts (NC/NO) 85
 - Empty-pipe/Full-pipe adjustment 86
- Commubox FXA 195 (electrical connection) 48, 90
- Communication 60
- Conductivity of fluid 116
- Conductivity of the fluid
 - Length of connecting cable (remote version) 20
- Connection
 - HART 48
 - Remote version 40
 - See Electrical connection
- Control
 - Device description files 62
 - Field Xpert HART Communicator 61
 - FieldCare 61
- C-tick mark 10, 126
- Current input
 - Active/passive configuration 84
 - Technical data 111

Current output

- Active/passive configuration 82
- Technical data 111

D

- Data back-up (of device data with T-DAT) 81
- Declaration of Conformity (CE mark) 10
- Degree of protection 51, 114
- Device description files 62
- Device designation 7
- Device functions
 - See the "Description of Device Functions" manual
- Display
 - Display 54
 - Display and operating elements 53
 - Local display 53
 - See Display
 - Turning the display 36
- Disposal 109
- Documentation, supplementary 128
- Down pipes 14
- Drinking water approval 126

E

- Electrical connection
 - Commubox FXA 191 48
 - Degree of protection 51
 - HART handheld terminal 48
 - Post-connection check (checklist) 52
 - Potential equalization 49
 - Terminal assignment, transmitter 47
- Electrode cleaning circuitry
 - See the "Description of Device Functions" manual 15
- Electrodes
 - Electrode Cleaning Circuitry (ECC) 15
 - EPD electrode 15
 - Measuring electrode plane 15
 - Reference electrode (potential equalization) 15
- Electronics boards
 - See Printed circuit boards
- EMC (Electromagnetic compatibility) 44
- EMC (electromagnetic compatibility) 115
- Empty pipe detection (EPD)
 - EPD electrode 15
- Empty-pipe/Full-pipe adjustment 86
- Environment 114
- Error limits
 - See Performance characteristics
- Error messages
 - Confirming error messages 59
 - Process error (application error) 96
 - System errors (device errors) 93
- Error types (system and process errors) 59
- European Pressure Equipment Directive 127
- Ex approval 126
- Exterior cleaning 88

F	
Failsafe mode inputs/outputs	99
F-Chip	87
Field Xpert SFX100	48
FieldCare	61
Fieldcheck (tester and simulator)	91
Fitted electrodes	124
Flow rate/limits	18
Frequency output	
Technical data	111
Function check	72
Function descriptions	
See the "Description of Device Functions" manual	
Function matrix (operation)	57
Fuse, replacing	106
FXA193	91
FXA195	90
G	
Galvanic isolation	112
Ground cable	
Promag P	27
Promag W	21
Grounding rings	
Promag H	33
H	
HART	
Command groups	60
Command No.	63
Error messages	63
Field Xpert HART Communicator	61
Write protection, switching on and off	71
Hazardous substances	109
High-temperature version	
Installation	28
Temperature ranges	28
HOME position (operating mode display)	53
I	
Incoming acceptance	11
Inlet run	16
Input	111
Input signal	111
Installation	
Wall-mount housing	37
Installation conditions	
Down pipes	14
Foundations, supports	17
Inlet and outlet runs	16
Installing pumps	13
Mounting location	13
Orientation (vertical, horizontal)	15
Partially filled pipes	14
Vibrations	16
Installing the sensor	
Adapters	17
Foundations (DN > 300)	17
High-temperature version	28

Promag H	32
Promag P	27
Promag W	21
Insulation of pipes (installing Promag P)	28
L	
Language groups	126
Length of connecting cable (remote version)	114
Load (output signal)	112
Local display	
See Display	
Low flow cutoff	112
M	
Maintenance	88
Material	123
Material load diagrams	124
Measured variable	111
Measuring electrodes	
See Electrodes	
Measuring principle	111
Measuring range	111
Measuring system	7, 111
Measuring tube	
Lining, temperature range	115
Medium pressure range	116
Medium temperature range	115
N	
Nameplate	
Connections	9
Sensor	8
Transmitter	7
Nominal diameter and flow rate	18
O	
Operable flow range	111
Operating conditions	114
Operating elements	53
Operation	
Display and operating elements	
Function matrix	57
Operational safety	5
Order code	
Accessories	89
Sensor	8
Transmitter	7
Ordering information	128
Outlet runs	16
Output	111
Output signal	111
P	
Performance characteristics	
Maximum measured error	113
Reference operating conditions	113
Pigs (cleaning)	34
Post-installation check (checklist)	39
Power consumption	112
Power supply	112

- Power supply failure 113
- Pressure loss
 Adapters (reducers, expanders) 17
 General information 118
- Pressure measuring device approval 127
- Pressure tightness 117
- Printed circuit boards, removing and installing
 Field housing 102
 Wall-mount housing 104
- Process connection 125
- Process error
 Definition 59
- Process error messages 96
- Programming mode
 Disable 58
 Enable 58
- Promag H
 Cleaning using pigs 34
 Grounding rings 33
 Installation 32
 Seals 32
 Weld nipple 34
- Promag P
 Ground cable 27
 High-temperature version 28
 Installation 27
 Seals 27
 Tightening torques 28
- Promag W
 Ground cable 21
 Installation 21
 Seals 21
 Tightening torques 22
- Pulsating flow 75
- Pulse output
 See Frequency output
- Pumps
 Mounting location 13
 Pump types, pulsating flow 75
- Q**
- Quick Setup
 Batching 78
 Commissioning 74
 Data back-up (of device data with T-DAT) 81
 Pulsating flow 75
 Transfer data 81
- R**
- Registered trademarks 10
- Relay output
 Configure relay contact (NC/NO) 85
 Technical data 112
- Remote operation 126
- Remote version
 Connection 40
- Repair 109
- Replacing
 Device fuse 106
- Electronics boards (installing/removing) 102
- Exchangeable electrode 107
- Returning devices 109
- S**
- Safety icons 6
- Safety instructions 5
- Sanitary compatibility 126
- S-DAT (HistoROM) 87
- Seals 88
 Promag H 32
 Promag P 27
 Promag W 21
- Seals (sensor process connection) 21, 27
- Sensor installation
 See Installing sensor
- Serial number 7–9
- Service interface
 Commubox FXA291 91
- Shock resistance 114
- Signal on alarm 112
- SIP cleaning 115
- Software
 Amplifier display 72
 Versions (History) 109
- Spare parts 101
- Standards, guidelines 127
- Status input
 Technical data 111
- Storage 12
- Storage temperature 114
- Supply voltage 112
- Surface roughness 125
- Switching output
 See Relay output
- System error
 Definition 59
- System error messages 93
- T**
- T-DAT (HistoROM)
 Description 87
 Save/load (data back-up, e.g. for replacing devices) ... 81
- Technical data at a glance 111
- Temperature
 Storage 114
- Temperature ranges
 Ambient temperature range 114
 Fluid temperature 115
- Tightening torques
 Promag P 28
 Promag W 22
- Transmitter
 Electrical connection 45
 Installing the wall-mount housing 37
 Length of connecting cable (remote version) 20
 Turning the field housing (aluminum) 35
 Turning the field housing (stainless steel) 35
- Transporting the sensor 11

Troubleshooting instructions	92
V	
Vibration resistance	114
Vibrations	16
Measures to prevent vibrations.	16
Shock and vibration resistance	114
W	
Wall-mount housing, installing	37
Weight	
(SI units)	119
(US units)	121
Weld nipple, Promag H	34
Wiring	
See Electrical connection	
Write protection (HART on/off).	71

Declaration of Hazardous Material and De-Contamination *Erklärung zur Kontamination und Reinigung*

RA No.

Please reference the Return Authorization Number (RA#), obtained from Endress+Hauser, on all paperwork and mark the RA# clearly on the outside of the box. If this procedure is not followed, it may result in the refusal of the package at our facility.
Bitte geben Sie die von E+H mitgeteilte Rücklieferungsnummer (RA#) auf allen Lieferpapieren an und vermerken Sie diese auch außen auf der Verpackung. Nichtbeachtung dieser Anweisung führt zur Ablehnung ihrer Lieferung.

Because of legal regulations and for the safety of our employees and operating equipment, we need the "Declaration of Hazardous Material and De-Contamination", with your signature, before your order can be handled. Please make absolutely sure to attach it to the outside of the packaging.
Aufgrund der gesetzlichen Vorschriften und zum Schutz unserer Mitarbeiter und Betriebseinrichtungen, benötigen wir die unterschriebene "Erklärung zur Kontamination und Reinigung", bevor Ihr Auftrag bearbeitet werden kann. Bringen Sie diese unbedingt außen an der Verpackung an.

Type of instrument / sensor
Geräte-/Sensortyp _____

Serial number
Seriennummer _____

Used as SIL device in a Safety Instrumented System / Einsatz als SIL Gerät in Schutzeinrichtungen

Process data / Prozessdaten Temperature / *Temperatur* _____ [°F] _____ [°C] Pressure / *Druck* _____ [psi] _____ [Pa]
Conductivity / *Leitfähigkeit* _____ [µS/cm] Viscosity / *Viskosität* _____ [cp] _____ [mm²/s]

Medium and warnings
Warnhinweise zum Medium



	Medium / concentration <i>Medium / Konzentration</i>	Identification CAS No.	flammable <i>entzündlich</i>	toxic <i>giftig</i>	corrosive <i>ätzend</i>	harmful/ irritant <i>gesundheitsschädlich/ reizend</i>	other * <i>sonstiges*</i>	harmless <i>unbedenklich</i>
Process medium <i>Medium im Prozess</i>								
Medium for process cleaning <i>Medium zur Prozessreinigung</i>								
Returned part cleaned with <i>Medium zur Endreinigung</i>								

* explosive; oxidising; dangerous for the environment; biological risk; radioactive
* *explosiv; brandfördernd; umweltgefährlich; biogefährlich; radioaktiv*

Please tick should one of the above be applicable, include safety data sheet and, if necessary, special handling instructions.
Zutreffendes ankreuzen; trifft einer der Warnhinweise zu, Sicherheitsdatenblatt und ggf. spezielle Handhabungsvorschriften beilegen.

Description of failure / Fehlerbeschreibung _____

Company data / Angaben zum Absender

Company / <i>Firma</i> _____	Phone number of contact person / <i>Telefon-Nr. Ansprechpartner:</i> _____
Address / <i>Adresse</i> _____	Fax / E-Mail _____
_____	Your order No. / <i>Ihre Auftragsnr.</i> _____

"We hereby certify that this declaration is filled out truthfully and completely to the best of our knowledge. We further certify that the returned parts have been carefully cleaned. To the best of our knowledge they are free of any residues in dangerous quantities."

"Wir bestätigen, die vorliegende Erklärung nach unserem besten Wissen wahrheitsgetreu und vollständig ausgefüllt zu haben. Wir bestätigen weiter, dass die zurückgesandten Teile sorgfältig gereinigt wurden und nach unserem besten Wissen frei von Rückständen in gefahrbringender Menge sind."

(place, date / *Ort, Datum*)

Name, dept. / *Abt.* (please print / *bitte Druckschrift*)

Signature / *Unterschrift*

www.endress.com/worldwide

Endress+Hauser 
People for Process Automation
