

## R400 Series – Data Sheets



- 100,000 d @ 0.25  $\mu$ V/d
- Trade approved Australia, Europe and USA
- Built in RS232/RS485
- IP65 ABS or stainless steel housing
- 16 x 350 ohm cells
- Ethernet and Profibus DP support
- Robust precise analogue output module

The R400 series of indicators are designed with both the installer and operator in mind and cover a wide range of applications. They are engineered and built to last with reliability being foremost. The modular design allows for the installation to be commissioned with only the components required, saving on time and money. With upwards of nine (9) versions of firmware available the R400 indicator is an ideal for distributors dealers and distributors as it simplifies installer training and reducing stocking levels.

**Flexibility** is the key with its award winning modular accessory design. Modules include: additional serial options, input/outputs, analogue outputs, external buttons, Ethernet, Alibi (Data Storage Device) and battery or AC option.

**Superior housings** - two housing types are available:

- R420 (ABS) rated to IP65
- R423 (stainless steel) rated to IP66

Both housings are designed with extra attention to detail to increase their reliability in the field, thereby reducing unplanned downtime and servicing costs. For example, the R423 uses a high impact polycarbonate lens to protect the LCD from knocks.

**Simple setup** - use the menu system directly via the alpha numeric keypad or the configuration utility View400 on a PC.

**Operator friendly** - large multi-segment display that uses logical prompts along with dedicated and programmable function keys. Printing can be tailored with custom record, docket or reports printouts. Primary display is 29mm (1.1") and secondary display 18mm.

**Rugged Load Cell Input** - Designed to take 16x320 ohm load cells; providing flexibility and reducing the need for summing hardware, simplifying the installation and saving money. The load cell input is protected with onboard transorbs to limit damage from external voltage surges.

**Networking Capability** - Support for both Ethernet and Profibus DP to improve integration into larger control systems

### Modules

The R400 Series flexibility is provided through its broad range of modules that are easy to configure and neatly connect into the rear of the indicator. There are 4 module slots where an indicator can be equipped with only the features required for a given installation.

#### Robust Input/Output Modules (M4301, M4311, M4321, M4331)

An R400 indicator can be equipped with up to 32 I/O. These I/O are electrically isolated, designed for direct connection into PLC's and are capable of driving low voltage actuators directly.

- Isolated high side (400mA current source) drivers are capable of driving low voltage actuators directly or can be connected directly with PLC controllers.
- Each module has 8 digital I/O ports which are limited to maximum input voltage of 30V and can drive up to 400mA.
- Direct connection between I/O points is supported
- Inputs are isolated to resist against system noise.

#### Button Module (M4302)

The Button Module provides 4 voltage free inputs for use with switches or thumbwheels. The voltage free inputs eliminate the need to wire up complicated input driver circuits.

#### Isolated Communication Modules

Communication modules are in addition the built in RS232/RS485 ports on the R400 indicators.

- **Fully isolated** and recommended for application where there is a risk of lightning or surges or where additional communication ports are required.
- M4201 RS232/RS232, M4202 RS232/RS485, M4203 RS485/RS485

#### Precise Robust Analogue Output Module (M4401)

The analogue module provides a 4-20mA or 0-10V analogue output and two digital I/O.

- **Isolated** so as to resist against system noise and interference therefore reducing unnecessary callouts;
- **Precise** with a 400Hz (2.5msec) update rate and 1/65,000 resolution. The fast update and high D to A conversion rate give a smooth output curve which helps a PLC to see more realistic readings (2.5msec step)
- **Scalable** to suit the input on the PLC.
- **Two digital I/O** provided the same as the M4301

#### Data Storage Device Module (M4501)

The Data Storage Module provides non volatile alibi memory storage (6M bytes) according to WELMEC 7.2 L. Compatible with later versions of software.

#### Ethernet (M4221)

The Ethernet Module provides 10/100 Base TX with auto negotiation (1 Raw bi-directional port and 10 Raw transmit only ports).

## Accessories

#### Converter 0-10V/4-20mA Input (M4902)

Connects to the Load Cell Input on R400 series indicators for a voltage or current input. Useful where an indicator needs to take an input from load pins on a crane scale for example. Suitable for pressure, displacement or strain transducers that output 4-20mA or 0-10V analogue signals.

#### rin-LINK

The magnetically coupled rin-LINK on the front panel provides a convenient temporary connection to a laptop - no need to access rear of the indicator.

- Transfer of setup and calibration information
- Download of software upgrades

#### Relay Modules (M4901 and M4906)

The relay modules, used in conjunction with an I/O module, provide 8 voltage free relay outputs rated to 250VAC and 8A, available in either 12 or 24V.

- DIN rail mountable.
- Provides N/O (normally open) and N/C (normally closed) contacts for each output.

## Smart Weighing

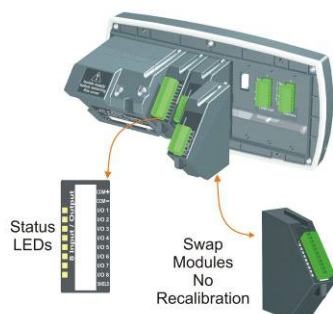

#### Superior Diagnostics

R400 series indicators have a range of diagnostic tools and features that aid system commissioning and maintenance.

**Hardware configuration report** summarises how the indicator hardware is setup, providing a record for maintenance purposes or fault finding

**Force Output and Test Input functions** allow the installer to specifically test I/O to assist in site setup

**Modules can be swapped** in and out without recalibration of the indicator, saving time and effort

**Status LED** on each I/O;

**Overload counter** to review if the scale has been overloaded.

## R400 Series – K405 Static Axle – Data Sheet

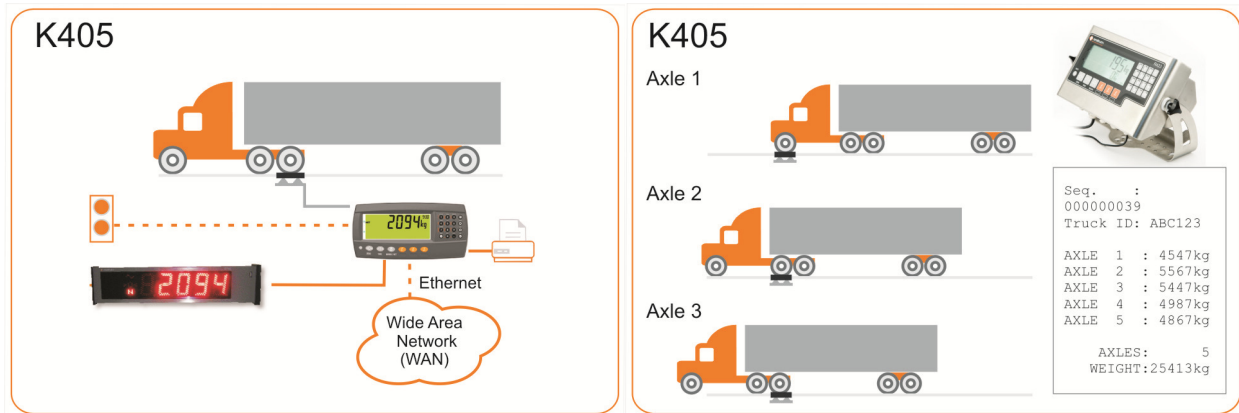

- 250 Truck IDs (Products)
- Preset Tare and accumulation data on each Truck ID
- Single and two pass weighing
- Alpha-numeric Truck ID names
- Programmable printing
- Automatic Print on no motion
- Simple two button operation

The K405 builds on the K404 standard truck weighing application to support static axle weighing rather than a full weigh bridge. There is automatic print on no motion for each axle.

Like the K404 it allows for a range of operational scenarios all in one setup, from weigh-in/weigh-out to stored truck ids. The alpha-numeric keypad allows for easy entry of tare weight and Truck IDs. With 250 Truck IDs available it is suitable for applications with truck fleets of up to 250.

### The following operational scenarios can all be handled on the one setup:

- Weigh a truck in a single pass using its tare weight
- Weigh a known truck with a stored Truck ID and preset tare and accumulate the statistics on that truck ID.
- Two pass weighing with a weigh in followed by a weigh out. The ticket will show time/date weigh-in, weigh-out and net weights.
- Automatic temporary Truck ID to simplify weigh-in/weigh-out for fast weighing throughput. The temporary Truck ID is removed once the weigh-out is complete.

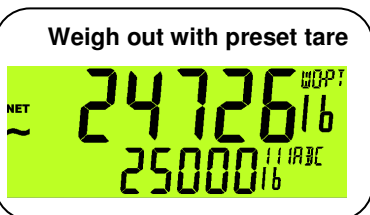

### R400 Indicators are ideal for weigh bridges:

- Isolated communication modules for excellent protection against lightning
- All accessory modules, including the power supply, can be swapped without recalibration.
- Indicator configuration and setup can be reused and easily uploaded using the opto-link on the front panel.
- Pre-calibration using mV/V saving time on full calibration

### Smart Weighing

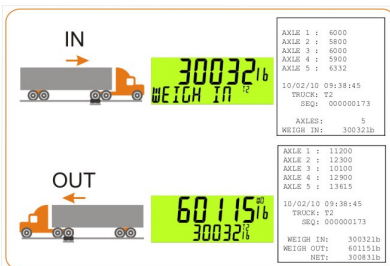

### Weigh In - Weigh Out

The K405 will record the weight of each axle on the way in again on the way out along with a print of each axle weight providing the driver with weight distribution.

The axle weight is printed automatically as no motion is detected.

*..now that's smart weighing.*

**R400 Series Specification Table**

<b>Resolution</b>	Up to 100,000 d, minimum of 0.25uV/d						
<b>Approvals</b>	10,000 d @0.7uV/d NMI(S-463), OIML R76 III/III L NTEP 08-720 FCC, CE, C-tick						
<b>Zero Cancellation</b>	+/- 2.0mV/V						
<b>Span Adjustment</b>	0.1mV/V to 3.0mV/V						
<b>Excitation</b>	7.4V for up to 16 x 350 or 32 x 700 ohm load cells (4-wire or 6-wire plus shield) Maximum total load cell resistance: 1,000 ohms						
<b>A/D Type</b>	24bit Sigma Delta with ±8,388,608 internal counts						
<b>Operating Environment</b>	Temperature: -10 to +50°C ambient (14 °F to 122 °F) Humidity: <90% non-condensing						
<b>Display</b>	LCD with 4 alpha-numeric displays and LED backlighting: Primary display: 6 x 28.4mm (1.12") high digits with units and annunciators 2 <sup>nd</sup> display: 9 x 17.6 mm (0.7") digits with units 3 <sup>rd</sup> display: 8 x 6.1 mm (0.2") digits 4 <sup>th</sup> display: 4 x 7.6 mm (0.3") digits						
<b>Setup and Calibration</b>	Full digital with visual prompting in plain messages						
<b>Digital Filter</b>	Sliding window average from 0.1 to 30.0 seconds						
<b>Zero Range</b>	Adjustable from +/- 2% to +/- 20% of full capacity						
<b>Standard Power Input</b>	12 to 24VDC (15 VA max) - ON/OFF key with memory feature						
<b>Variants</b>	<b>AC</b>	AC power supply Input: 110/240VAC 50/60Hz Output: 12VDC 15VA					
	<b>Battery</b>	2.5AH NiMH rechargeable battery pack Charger Input: 110/240VAC 50/60Hz Output: 12VDC					
<b>Optical Data Communications</b>	Magnetically coupled infra-red communications Conversion cables available for RS232 or USB						
<b>Correction</b>	10 point linearity correction						
<b>Serial Outputs</b>	Serial 1A: RS-232 serial port for remote display, network or printer supports. Serial 1B: RS485 transmit only for remote display Transmission rate: 2400, 4800, 9600 or 19200 baud						
<b>Assignable Function Keys</b>	3						
<b>Operating Modes</b>	Single Range, Dual Range and Dual Interval						
<b>Battery Backed Clock Calendar</b>	Battery life 10 years minimum						
<b>Application Software</b>	<b>K401</b>	<b>K402</b>	<b>K404</b>	<b>K405</b>	<b>K410</b>	<b>K411</b>	<b>K412</b>
<b>Functions</b>	Custom printing, custom unit switching, counting, manual hold, peak hold, auto output totalising		Weighbridge	Static Axle	1 Material	6 Material	20 Material
			Single pass weighing Two pass weighing Dedicated truck key Custom printing Temporary Truck IDs Preset Tare Specialised truck dockets		Up to 10 Batching Stages 3 Speed Fill Fill, Dump & Pulse stages Inflight & jogging correction, Negative batching Batch suspend Timer (RTC) based multiple batching		
<b>Products/Recipes</b>	1	250	250 Trucks		100 Recipes		
<b>Analogue Output * (M4401)</b>	1		-			1	-
<b>Set points</b>	8						
<b>Additional Communications *</b>	Module: RS232/RS232 Module: RS232/RS485 Module: RS485/RS485						
<b>Button Input *</b>	4 Buttons						
<b>Data Storage Device * (M4501)</b>	1						
<b>Profibus-DP</b>	Used with Rinstrum 1400 Profibus-DP Module						
<b>Ethernet * (M4221)</b>	1						
<b>Housing Options</b>	<b>R420</b>			<b>R423</b>			
<b>Case Materials</b>	ABS			Stainless Steel			
<b>Packing Weights</b>	Indicator: 1kg (35 oz)			Indicator: 1.2kg (42 oz)			
<b>Environmental IP Rating</b> (panel mounted or with rear boot)	IP65			IP66			

R420 Rear Boot for IP65 standalone unit		R420 Brackets		R423 Bracket
				
Rear Boot	Rear Boot with Desk Stand	Stainless Steel Wall Mounting M4003	Stainless Steel Post Mounting M4004	Stainless Steel Desk/Wall/Post Mounting

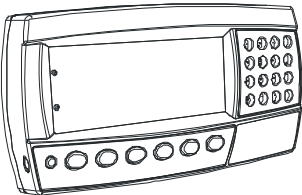
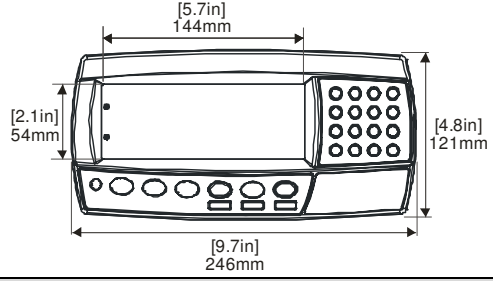
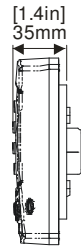
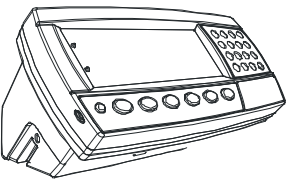
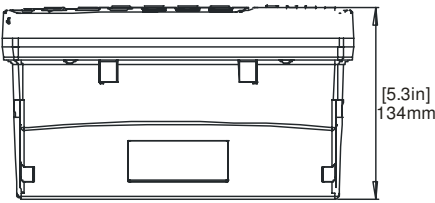
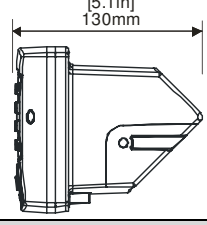
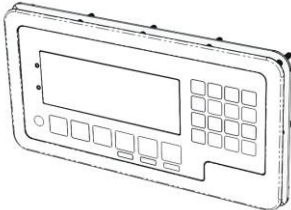
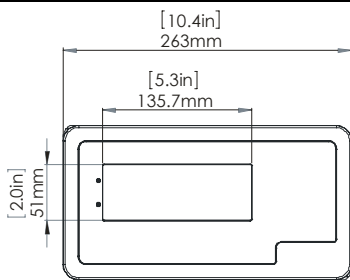
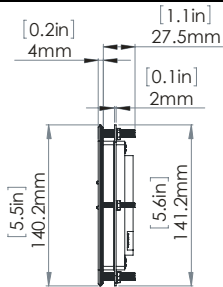
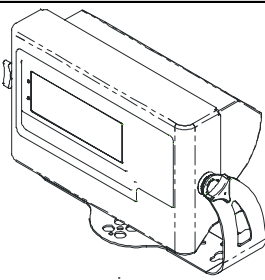
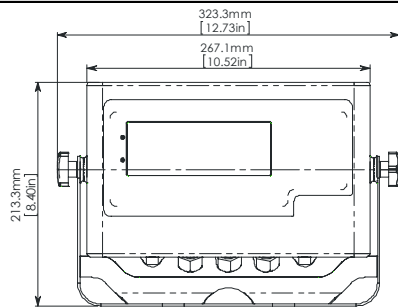
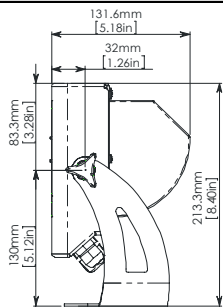
ABS Panel Mount		
		
ABS with Rear Boot		
		
Stainless Steel Panel Mount		
		
Stainless Steel with Rear Housing and Stand		
		

Specifications are subject to variation for improvement without notice. Illustrations are indications only and variation may be evident between products.

\*Optional modules