

R400 Series – Data Sheets



- 100,000 d @ 0.25 μ V/d
- Trade approved Australia, Europe and USA
- Built in RS232/RS485
- IP65 ABS or stainless steel housing
- 16 x 350 ohm cells
- Ethernet and Profibus DP support
- Robust precise analogue output module

The R400 series of indicators are designed with both the installer and operator in mind and cover a wide range of applications. They are engineered and built to last with reliability being foremost. The modular design allows for the installation to be commissioned with only the components required, saving on time and money. With upwards of nine (9) versions of firmware available the R400 indicator is an ideal for distributors dealers and distributors as it simplifies installer training and reducing stocking levels.

Flexibility is the key with its award winning modular accessory design. Modules include: additional serial options, input/outputs, analogue outputs, external buttons, Ethernet, Alibi (Data Storage Device) and battery or AC option.

Superior housings - two housing types are available:

- R420 (ABS) rated to IP65
- R423 (stainless steel) rated to IP66

Both housings are designed with extra attention to detail to increase their reliability in the field, thereby reducing unplanned downtime and servicing costs. For example, the R423 uses a high impact polycarbonate lens to protect the LCD from knocks.

Simple setup - use the menu system directly via the alpha numeric keypad or the configuration utility View400 on a PC.

Operator friendly - large multi-segment display that uses logical prompts along with dedicated and programmable function keys. Printing can be tailored with custom record, docket or reports printouts. Primary display is 29mm (1.1") and secondary display 18mm.

Rugged Load Cell Input - Designed to take 16x320 ohm load cells; providing flexibility and reducing the need for summing hardware, simplifying the installation and saving money. The load cell input is protected with onboard transorbs to limit damage from external voltage surges.

Networking Capability - Support for both Ethernet and Profibus DP to improve integration into larger control systems

Modules

The R400 Series flexibility is provided through its broad range of modules that are easy to configure and neatly connect into the rear of the indicator. There are 4 module slots where an indicator can be equipped with only the features required for a given installation.

Robust Input/Output Modules (M4301, M4311, M4321, M4331)

An R400 indicator can be equipped with up to 32 I/O. These I/O are electrically isolated, designed for direct connection into PLC's and are capable of driving low voltage actuators directly.

- Isolated high side (400mA current source) drivers are capable of driving low voltage actuators directly or can be connected directly with PLC controllers.
- Each module has 8 digital I/O ports which are limited to maximum input voltage of 30V and can drive up to 400mA.
- Direct connection between I/O points is supported
- Inputs are isolated to resist against system noise.

Button Module (M4302)

The Button Module provides 4 voltage free inputs for use with switches or thumbwheels. The voltage free inputs eliminate the need to wire up complicated input driver circuits.

Isolated Communication Modules

Communication modules are in addition the built in RS232/RS485 ports on the R400 indicators.

- **Fully isolated** and recommended for application where there is a risk of lightning or surges or where additional communication ports are required.
- M4201 RS232/RS232, M4202 RS232/RS485, M4203 RS485/RS485

Precise Robust Analogue Output Module (M4401)

The analogue module provides a 4-20mA or 0-10V analogue output and two digital I/O.

- **Isolated** so as to resist against system noise and interference therefore reducing unnecessary callouts;
- **Precise** with a 400Hz (2.5msec) update rate and 1/65,000 resolution. The fast update and high D to A conversion rate give a smooth output curve which helps a PLC to see more realistic readings (2.5msec step)
- **Scalable** to suit the input on the PLC.
- **Two digital I/O** provided the same as the M4301

Data Storage Device Module (M4501)

The Data Storage Module provides non volatile alibi memory storage (6M bytes) according to WELMEC 7.2 L. Compatible with later versions of software.

Ethernet (M4221)

The Ethernet Module provides 10/100 Base TX with auto negotiation (1 Raw bi-directional port and 10 Raw transmit only ports).

Accessories

Converter 0-10V/4-20mA Input (M4902)

Connects to the Load Cell Input on R400 series indicators for a voltage or current input. Useful where an indicator needs to take an input from load pins on a crane scale for example. Suitable for pressure, displacement or strain transducers that output 4-20mA or 0-10V analogue signals.

rin-LINK

The magnetically coupled rin-LINK on the front panel provides a convenient temporary connection to a laptop - no need to access rear of the indicator.

- Transfer of setup and calibration information
- Download of software upgrades

Relay Modules (M4901 and M4906)

The relay modules, used in conjunction with an I/O module, provide 8 voltage free relay outputs rated to 250VAC and 8A, available in either 12 or 24V.

- DIN rail mountable.
- Provides N/O (normally open) and N/C (normally closed) contacts for each output.

Smart Weighing

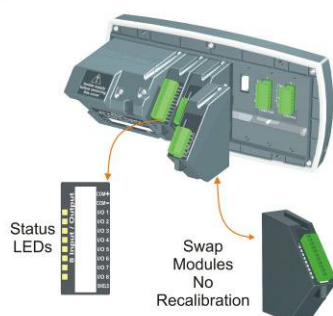

Superior Diagnostics

R400 series indicators have a range of diagnostic tools and features that aid system commissioning and maintenance.

Hardware configuration report summarises how the indicator hardware is setup, providing a record for maintenance purposes or fault finding

Force Output and Test Input functions allow the installer to specifically test I/O to assist in site setup

Modules can be swapped in and out without recalibration of the indicator, saving time and effort

Status LED on each I/O;

Overload counter to review if the scale has been overloaded.

R400 Series – K481 – Data Sheet

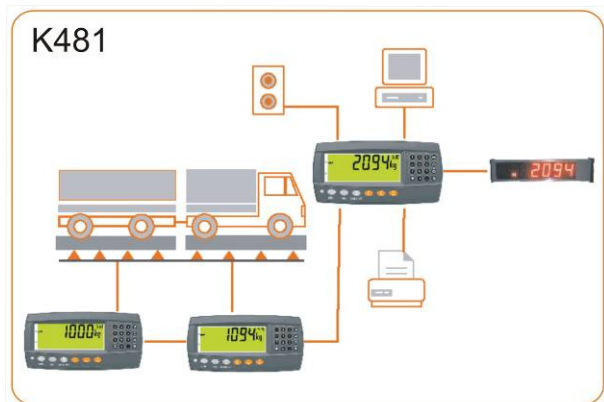
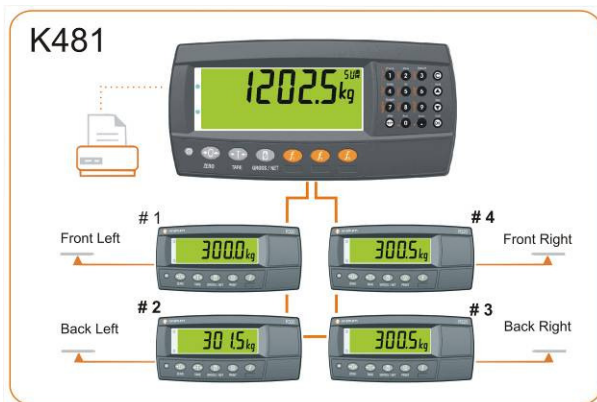

- Up to 9 slave units
- Up to 4 subtotals
- Subtotal can add or subtract slave values
- Sum R300 indicators
- Sum R400 indicators
- Built in serial ports
- Complies to Technical Schedule S1/O/A

The K481 Summing Indicator is based on the R400 Series indicator hardware. It shares the same style operator interface and setup menus making it easy for both the operator and the installer. The K481 can sum both R300 Series and R400 Series indicators.

Sum Nine (9) Slave Units: The K481 can sum up to nine slave indicators from either the R300 or R400 range. These can be connected together on a multi-drop serial RS485 bus or RS232 ring network. The summing indicator polls each of the slave units summing all of the weight readings, and displays the resulting total weight.

Four (4) Subtotals: Up to 4 subtotals can be defined to add or subtract slave values. Each subtotal can be named to assist the operator and for custom printing.

Support for R400 Series Modules and Accessories: The K481 uses the R400 series Accessories and supports many of the R400 series modules – additional communications modules, button module, input/output modules and analogue module.

Applications: multiple deck weigh bridges, car balancing systems, aircraft weighing, medical bed weighing applications and shipyard centre of gravity ballast determination.



Smart Weighing

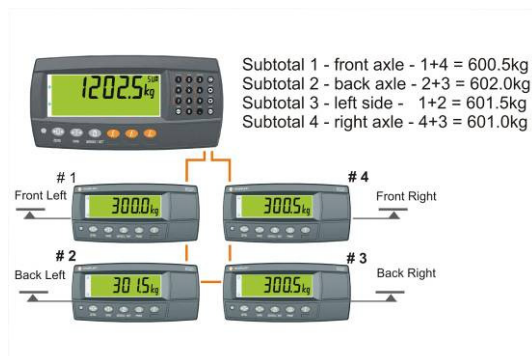

Designed to support applications where balance or relative weight is important.

Up to 4 subtotals can be defined - these subtotals can add or subtract slave weight values. In a car balancing scenario four subtotals are defined:

- Front Axle = 1+4
- Back Axle = 2+3
- Left Side = 1+2
- Right Side = 3+4

..now that's smart weighing.

R420 Rear Boot for IP65 standalone unit		R420 Brackets		R423 Bracket
				
Rear Boot	Rear Boot with Desk Stand	Stainless Steel Wall Mounting M4003	Stainless Steel Post Mounting M4004	Stainless Steel Desk/Wall/Post Mounting

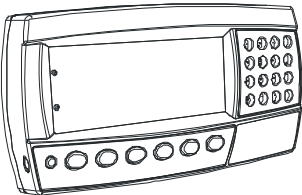
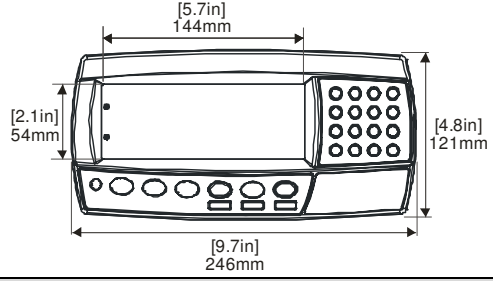
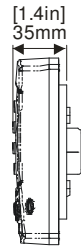
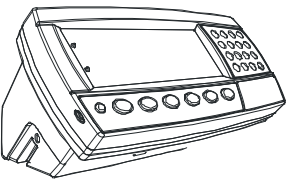
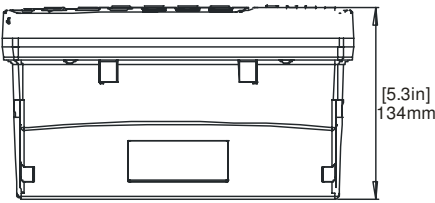
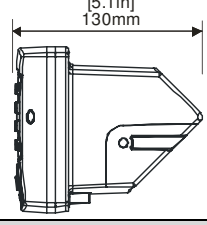
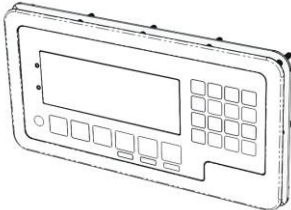
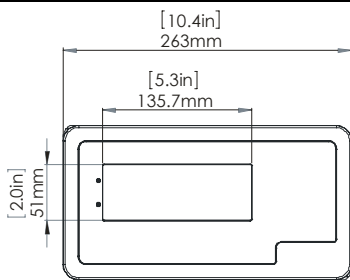
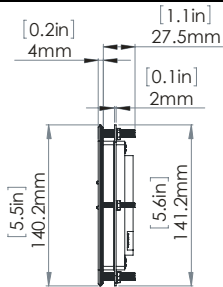
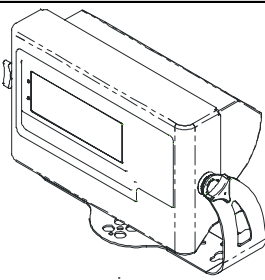
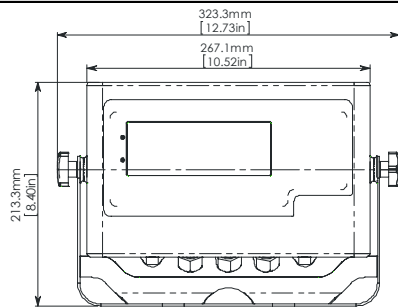
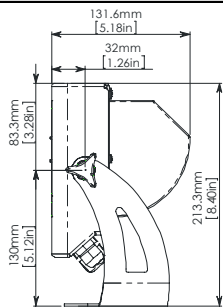
ABS Panel Mount		
	 <p> [5.7in] 144mm [2.1in] 54mm [4.8in] 121mm [9.7in] 246mm </p>	
ABS with Rear Boot		
	 <p> [5.3in] 134mm </p>	
Stainless Steel Panel Mount		
	 <p> [10.4in] 263mm [5.3in] 135.7mm [2.0in] 51mm </p>	 <p> [0.2in] 4mm [1.1in] 27.5mm [0.1in] 2mm [5.5in] 140.2mm [5.6in] 141.2mm </p>
Stainless Steel with Rear Housing and Stand		
	 <p> 323.3mm [12.73in] 267.1mm [10.52in] 213.3mm [8.40in] </p>	 <p> 131.6mm [5.18in] 32mm [1.26in] 83.3mm [3.28in] 130mm [5.12in] 213.3mm [8.40in] </p>

Specifications are subject to variation for improvement without notice. Illustrations are indications only and variation may be evident between products.

*Optional modules