

SMART WEIGHING SOLUTIONS

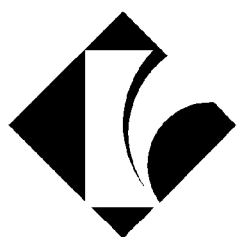

**rinstrum**

**400 Series**  
**(K401, K402, K403, K491)**  
**Digital Indicator**  
**Reference Manual**

RI00-600-120

## **Copyright**

All Rights Reserved. No part of this document may be copied, reproduced, republished, uploaded, posted, transmitted, distributed, stored in or introduced into a retrieval system in any form, or by any means (electronic, mechanical, photocopying, recording or otherwise) whatsoever without prior written permission of Rinstrum Pty Ltd.

## **Disclaimer**

Rinstrum Pty Ltd reserves the right to make changes to the products contained in this manual in order to improve design,  
performance or reliability.

The information in this manual is believed to be accurate in all respects at the time of publication, but is subject to change without notice. Rinstrum Pty Ltd assumes no responsibility for any errors or omissions and disclaims responsibility for any consequences resulting from the use of the information provided herein.

## Table of Contents

<b>1.</b>	<b>INTRODUCTION .....</b>	<b>6</b>
1.1.	Overview .....	6
1.2.	Document Conventions .....	6
1.3.	Software Comparison K401, K402, K403 and K491 .....	7
<b>2.</b>	<b>SPECIFICATIONS .....</b>	<b>8</b>
<b>3.</b>	<b>INSTALLATION .....</b>	<b>9</b>
3.1.	Introduction .....	9
3.2.	General Warnings .....	9
3.3.	Electrical Safety.....	9
3.4.	Cleaning .....	9
3.5.	Panel Mount Template.....	9
3.6.	Cable Connections.....	9
3.7.	DC Power (DC PWR + , DC PWR –) .....	10
3.8.	Load Cell Connection.....	10
3.8.1.	Load Cell Signals and Scale Build.....	10
3.8.2.	4-Wire Connection .....	10
3.8.3.	6-Wire Connection .....	11
3.9.	Auxiliary Connections .....	11
3.9.1.	RS-232 Serial.....	12
3.9.2.	RS-485 Serial.....	14
3.10.	Optical Communications.....	15
3.11.	Connecting Shields .....	16
3.11.1.	Cable Shield Connection and Earthing .....	17
3.12.	Regulatory Sealing Requirements .....	17
3.13.	Accessory Module connection .....	18
<b>4.</b>	<b>SETUP MENUS.....</b>	<b>19</b>
4.1.	Accessing Setup Menus .....	19
4.1.1.	Setup Display Prompts .....	20
4.2.	Exiting Full or Safe Setup .....	20
4.3.	Menu Navigation .....	20
4.4.	Changing Data.....	21
4.5.	Numeric Entry .....	21
4.6.	Selections and Options .....	22
4.7.	Strings .....	22
4.7.1.	Normal String Editing.....	22
4.7.2.	Numerical String Editing.....	23
4.7.3.	ASCII String Editing .....	23
4.8.	IP Addresses .....	23
<b>5.</b>	<b>BASIC OPERATION.....</b>	<b>24</b>
5.1.	User Interface Display and Controls.....	24
5.1.1.	Overview .....	24
5.1.2.	Display .....	25
5.1.3.	Primary Annunciators .....	25
5.1.4.	Keypad.....	26
5.2.	Operation Keys.....	27
5.2.1.	Power Key .....	27
5.2.2.	Zero Key .....	28
5.2.3.	Tare Key .....	28
5.2.4.	Gross/Net Key .....	30
5.2.5.	Function Keys.....	30
5.2.6.	Up, Down, OK keys: Products (K402, K403 and K491 only) .....	31
5.2.7.	Clock .....	33
5.2.8.	View.....	34
5.2.9.	Report .....	34
5.2.10.	Total .....	35
5.2.11.	User ID.....	35
5.2.12.	Target.....	36
5.2.13.	Lock.....	36

5.2.14.	Alibi.....	37
5.2.15.	Acc.....	38
5.2.16.	Stability Considerations .....	38
<b>6.</b>	<b>CONFIGURATION .....</b>	<b>39</b>
6.1.	General Setup Information .....	39
6.2.	Correct Loadcell Selection .....	39
6.3.	Filtering Techniques.....	39
6.4.	Industrial vs Trade Modes .....	40
6.5.	Calibration Counter .....	40
6.6.	Passcodes .....	40
6.6.1.	Full Setup Passcode.....	40
6.6.2.	Safe Setup Passcode .....	41
6.6.3.	Operator Passcode.....	41
6.6.4.	Setup Lock-Out .....	41
<b>7.</b>	<b>SETUP MENUS.....</b>	<b>42</b>
7.1.	GEN.OPT (General options) .....	42
7.1.1.	LANG (Operator language) .....	42
7.1.2.	P.T.SCP (Preset Tare Scope).....	42
7.1.3.	DATE.F (Date format).....	42
7.1.4.	PCODE (Security passcodes).....	43
7.1.5.	KEY.LOC (Key Function Access Control).....	43
7.1.6.	DISP (Display options) .....	44
7.1.7.	ID.NAME (User Defined Strings) .....	44
7.1.8.	POWER (Power options).....	45
7.1.9.	STR.EDT (String Edit Mode).....	45
7.1.10.	USR.DEF (Set all non-calibration settings to defaults) .....	45
7.2.	H.WARE (Hardware Configuration & Test).....	46
7.2.1.	ALLOC (Allocation Report).....	46
7.2.2.	LC.HW.....	46
7.2.3.	SER1.HW, SER2.HW .....	47
7.2.4.	ETH.HW .....	48
7.2.5.	ETH.DEF (Set the M4221 Ethernet module to defaults) .....	48
7.2.6.	IO.HW .....	49
7.2.7.	ANL.HW .....	49
7.2.8.	DSD.HW .....	50
7.2.9.	TILT.HW (K491 Only) .....	50
7.3.	SCALE (Loadcell options and calibration) .....	51
7.3.1.	BUILD (Scale parameters) .....	51
7.3.2.	OPTION (Scale options).....	52
7.3.3.	CAL (Scale calibration).....	53
7.3.4.	QA (QA alarm).....	53
7.4.	FUNC (Special functions).....	54
7.4.1.	NUM (Number of special functions) .....	54
7.4.2.	SFn: TYPE (Function Types) .....	54
7.4.3.	SFn: KEY (Function Key / Remote Input ) .....	55
7.4.4.	SFn: PRINT (Printing Functions) .....	56
7.4.5.	SFn: SINGLE (Single Serial Output Functions).....	57
7.4.6.	SFn: BLANK (Blanking Functions) .....	57
7.4.7.	SFn: COUNT, SFn: PIECE (Counting Functions) .....	58
7.4.8.	SFn: UNITS (Unit Switching Functions) .....	59
7.4.9.	SFn: HOLD .....	59
7.4.10.	SFn: PK.HOLD (Peak Hold).....	60
7.4.11.	SFn: PRD.SEL (Product Select) .....	60
7.4.12.	SFn: THUMB (Thumbwheel Product Selection).....	60
7.4.13.	SFn: REM.KEY (Remote Key Functions) .....	61
7.4.14.	SFn: REPORT (Report Printing Functions) .....	61
7.4.15.	SFn: HI.RES (High Resolution) .....	62
7.4.16.	SFn: SC.EXIT (Scale Exit) .....	62
7.4.17.	SFn: SEMI.P.T (Semi-auto Preset Tare) .....	62
7.4.18.	SFn: A.TARE (Auto Tare).....	63
7.5.	SER.NET (Network communications K401, K402 and K491).....	64

7.6.	SER.NET (Network communications K403) .....	65
7.7.	SER.AUT (Automatic transmit) .....	66
7.7.1.	NUM (Number of Automatic Transmissions) .....	66
7.7.2.	AUTO.n (Automatic Output Configuration) .....	66
7.8.	PRINT (Printouts) .....	67
7.8.1.	NUM (Number of printouts) .....	67
7.8.2.	HEADER (Print header) .....	67
7.8.3.	FOOTER (Print footer) .....	67
7.8.4.	PAGE (Print page options) .....	67
7.8.5.	SPACE (Print blank space options) .....	68
7.8.6.	PRINT.n ... (Printout options) .....	68
7.9.	SETP (Setpoints) .....	69
7.9.1.	NUM (Number of setpoints) .....	69
7.9.2.	SETP1 ... SETP8 (Setpoint options) .....	69
7.10.	ANL.OUT (Analogue Output) .....	71
7.11.	End (Save and exit) .....	71
<b>8.</b>	<b>CALIBRATION</b> .....	<b>72</b>
8.1.	Performing a Digital Calibration with Test Weights .....	72
8.1.1.	ZERO (Zero Calibration Routine) .....	73
8.1.2.	SPAN (Span Calibration Routine) .....	74
8.1.3.	TILT (Tilt Calibration Routine K491 only) .....	75
8.2.	Performing a Calibration with Direct mV/V Entry .....	76
8.2.1.	DIR.ZER (Direct Zero Calibration Entry) .....	76
8.2.2.	DIR.SPN (Direct Span Calibration Entry) .....	76
8.3.	Using Linearisation .....	77
8.3.1.	ED.LIN (Edit Linearisation Points) .....	78
8.3.2.	CLR.LIN (Clear Linearisation) .....	78
8.4.	Calibration Errors .....	79
8.5.	Tilt Calibration Errors (K491 only) .....	80
<b>9.</b>	<b>NETWORK COMMUNICATIONS</b> .....	<b>81</b>
9.1.	Introduction .....	81
9.2.	Network Protocol B .....	81
9.2.1.	Basic Message Format .....	81
9.2.2.	Termination .....	82
9.2.3.	Error Handling .....	83
9.2.4.	Ring Network Enhancement .....	83
9.2.5.	Calibrating an instrument over a network .....	83
9.3.	Network Protocol USER.DEF (K403 only) .....	84
9.4.	Network Protocol SIMPLE .....	85
9.5.	Network Protocol BARCODE .....	85
9.6.	Protocol B Examples .....	86
<b>10.</b>	<b>AUTOMATIC WEIGHT OUTPUT</b> .....	<b>88</b>
10.1.	Overview .....	88
10.2.	Auto Weight Format String .....	88
<b>11.</b>	<b>PRINTING</b> .....	<b>89</b>
11.1.	Overview .....	89
11.2.	Print ID .....	89
11.3.	Record printouts .....	89
11.3.1.	K401 .....	89
11.3.2.	K402 .....	89
11.3.3.	Custom Record Events (K401 and K402) .....	90
11.4.	Docket printouts .....	90
11.4.1.	K401 .....	90
11.4.2.	K402 .....	91
11.4.3.	Custom Docket Events (K401 and K402) .....	91
11.5.	Report printouts .....	92
11.6.	Custom Printing .....	92
11.6.1.	Page Tokens .....	94
<b>12.</b>	<b>SPECIAL FUNCTIONS</b> .....	<b>95</b>
12.1.	Introduction .....	95

12.2.	Key Functions .....	95
12.2.1.	NONE .....	95
12.2.2.	PRINT .....	95
12.2.3.	SINGLE .....	96
12.2.4.	TEST .....	96
12.2.5.	COUNT .....	97
12.2.6.	PIECE .....	98
12.2.7.	UNITS .....	99
12.2.8.	HOLD .....	101
12.2.9.	PEAK HOLD .....	102
12.2.10.	PRD.SEL .....	104
12.2.11.	HI.RES .....	105
12.2.12.	SC.EXIT .....	106
12.2.13.	SEMI.P.T .....	106
12.2.14.	A.TARE .....	106
<b>13.</b>	<b>SETPOINTS .....</b>	<b>107</b>
13.1.	Overview .....	107
13.2.	Outputs .....	107
13.3.	Common Settings .....	107
13.4.	Weigh in (OVER) Setpoints and Weigh Out (UNDER) Setpoints .....	108
13.4.1.	Additional Settings .....	108
13.5.	Status Based Setpoint Types .....	109
13.6.	Logic Setpoint Types .....	109
13.7.	Scale Entry/Exit Setpoint Types .....	111
<b>14.</b>	<b>ANALOGUE OUTPUT .....</b>	<b>112</b>
14.1.	Overview .....	112
14.2.	Configuration of Hardware .....	112
14.2.1.	Configuration .....	112
14.2.2.	Calibration .....	112
14.2.3.	Testing .....	112
14.3.	Analogue Weight Transmission .....	112
<b>15.</b>	<b>APPENDIX 1: DIMENSIONS .....</b>	<b>113</b>
15.1.	Legal Sealing Details .....	115
15.1.1.	Trade Label .....	115
15.1.2.	Lead Seals .....	116
15.1.3.	Destructible Sticker Seals .....	117
15.1.4.	Electronic Seal .....	117
<b>16.</b>	<b>APPENDIX 2: PRINT AND AUTOMATIC TRANSMISSION TOKENS .....</b>	<b>118</b>
16.1.	ASCII codes .....	118
16.2.	Use of Characters in the Extended ASCII table .....	118
16.3.	Tokens .....	119
16.3.1.	Non-paged generic tokens .....	119
16.3.2.	Page tokens .....	119
16.3.3.	Page 0, 1, 2, 3, 7 tokens: Weight Information .....	120
16.3.4.	Page 4, 5, 6 tokens: Product Information: .....	121
16.3.5.	Page 8 tokens: Miscellaneous weight data .....	121
16.3.6.	Format tokens .....	122
<b>17.</b>	<b>APPENDIX 3: COMMUNICATIONS REGISTERS .....</b>	<b>123</b>
<b>18.</b>	<b>APPENDIX 4: SETUP MENU QUICK REFERENCE .....</b>	<b>130</b>
<b>19.</b>	<b>APPENDIX 5: ERROR MESSAGES .....</b>	<b>133</b>
19.1.	Overview .....	133
19.2.	Weighing Errors .....	133
19.3.	Setup Errors .....	133
19.4.	Diagnostic Errors .....	134
<b>20.</b>	<b>APPENDIX 6: M4221 ETHERNET MODULE .....</b>	<b>135</b>
20.1.	Overview .....	135
20.2.	Network Configuration .....	135
20.3.	Viewing the Current Configuration .....	135
20.4.	Services .....	135
20.4.1.	TCP Sockets .....	135

20.4.2.	Web Interface.....	135
<b>21.</b>	<b>APPENDIX 7: M4501 DSD MODULE.....</b>	<b>136</b>
21.1.	Overview.....	136
21.2.	Writing records.....	136
21.3.	Reading records.....	136
<b>22.</b>	<b>GLOSSARY.....</b>	<b>137</b>
22.1.	Glossary of Terms.....	137
22.2.	List of Figures.....	138
22.3.	List of Tables.....	138
<b>23.</b>	<b>INDEX.....</b>	<b>139</b>

# 1. Introduction

## 1.1. Overview

This precision digital indicator uses the latest Sigma-Delta A/D technology to ensure fast and accurate weight readings. The setup and calibration of the instrument are digital, with a non-volatile security store for all setup parameters.

It may be operated from either a DC power source (12V<sub>DC</sub> to 24V<sub>DC</sub>) or AC power (optional 110 – 240 VAC). There is a soft power on/off function that retains memory of its state. Once an instrument is turned on it will automatically start up again if the external power is interrupted.

Optical communications is fitted standard and allows for a temporary isolated communications link to be established with a PC. Software upgrades, the use of computerised setup and calibration can then be done using a PC. Refer to Optical Communications page 15 for more information.



**Figure 1: Weight Indicator**

The instrument provides zero, tare and gross/net on the fixed function keys and supports special functions (eg. peak-hold, counting, unit switching, etc.), via three (3) user definable function keys and external inputs. Operator functions (clock, view, report etc) and editing functions are provided on the alpha/numeric key pad. It is equipped with an NVRAM store to ensure day-to-day operating settings (eg. ZERO, TARE, CLOCK, etc.) are retained when power is removed.

The RS-232 communications port can be used for printer driving, connection to a remote display or PC. The transmit only RS-485 communications port can be used for remote displays. There is a built-in clock for date-stamping printed outputs.

The instrument can support different software applications depending on the functionality required. This manual covers the K401, K402, K403 and K491 software variants, where the software provides differing functionality, refer to 1.3 Software Comparison K401, K402, K403 and K491 page 7.

## 1.2. Document Conventions

The following document conventions (typographical) are used throughout this Reference Manual.

<b>Bold Text</b>	Bold text denotes words and phrases to note.
------------------	--

<Key>	<Key> denotes a Keypad key. <b>Note:</b> In the Specifications section the < symbol means <b>less than</b> and the > symbol means <b>greater than</b> .
^	This symbol denotes one space when describing serial output formats.
Ä	Items marked with ⊗ indicate that the setting is available only in Full Setup and is trade critical. When trade critical settings are changed the calibration counter is incremented.

Table 1: Document Conventions

### 1.3. Software Comparison K401, K402, K403 and K491

The table below only lists the features that vary between each version of the K401, K402, K403 and K491 software.

Feature	K401 v1	K402 v1	K403 v1	K491 v1	K401 v2	K402 v2	K403 v2	K491 v2
Input/Outputs	32	32	32	32	32	32	32	32
Setpoints	8	8	8	8	8	8	8	8
External Keys	8	8	8	8	8	8	8	8
Assignable Functions	8	8	8	8	8	8	8	8
Network ports	1	1	2	1	2	2	2	2
Network - Custom format			ü				ü	
Products	1	10	10	10	1	250	250	250
Tilt compensation				ü				ü
Automatic Output – Custom format	ü	ü	ü	ü	ü	ü	ü	ü
Single Automatic Output	ü	ü	ü	ü	ü	ü	ü	ü
Printouts	2	2	2	2	2	2	2	2
Custom Printouts	ü	ü	ü	ü	ü	ü	ü	ü

## 2. Specifications

Performance	
Resolution	Up to 100,000 divisions, minimum of 0.25 $\mu$ V/division
Zero Cancellation	+/- 2.0mV/V
Span Adjustment	0.1mV/V to 3.0mV/V
Stability/Drift	Zero: < 0.15 $\mu$ V/ $^{\circ}$ C (+ 10ppm of deadload max) Span < 10 ppm/ $^{\circ}$ C, Linearity < 20ppm, Noise < 0.2 $\mu$ Vp-p
Excitation	7.4 volts for up to 16 x 350 or 32 x 700 ohm load cells (4-wire or 6-wire plus shield) Maximum total load cell resistance: 1,000 ohms
A/D Type	24bit Sigma Delta with $\pm$ 8,388,608 internal counts
Operating Environment	Temperature: -10 to +50 $^{\circ}$ C ambient Humidity: <90% non-condensing Storage: -20 to +50 $^{\circ}$ C ambient IP55 when panel mounted or with rear boot (otherwise IP40)
Case Materials	ABS, Silicon Rubber, Nylon, Acrylic (no halogen used)
Packing Weights	Basic Indicator: 0.6kg
Digital	
Display	LCD with 4 alpha-numeric displays and LED backlighting: <ul style="list-style-type: none"> <li>• Primary display: 6 x 28.4mm high digits with units and annunciators</li> <li>• 2<sup>nd</sup> display: 9 x 17.6 mm digits with units</li> <li>• 3<sup>rd</sup> display: 8 x 6.1mm digits</li> <li>• 4<sup>th</sup> display: 4 x 7.6 mm digits</li> </ul>
Setup and Calibration	Full digital with visual prompting in plain messages
Digital Filter	Sliding window average from 0.1 to 30.0 seconds
Zero Range	Adjustable from +/- 2% to +/- 20% of full capacity
Power Input	
Standard Power Input	12 to 24VDC (15 VA max) - ON/OFF key with memory feature
Variants	AC M4101 Input: 110/240VAC 50/60Hz Output: 12VDC 15VA
Features	
Optical Data Communications	Magnetically coupled optical communications support. Optional conversion cable connects directly to a standard RS-232 port.
Correction	10 point linearity correction
Serial Outputs	RS-232 serial port for remote display, network or printer supports. RS-485 transmit only for remote display Transmission rate: 1200, 2400, 4800, 9600, 19200 or 57600 baud
3 assignable function keys	Printing, unit switching, counting, manual hold, peak hold and totalising
Battery Backed Clock Calendar	Battery life 10 years minimum
Approvals	FCC, CE, C-tick Check trade approvals

**Table 2: Instrument specifications**

## 3. Installation

### 3.1. Introduction

The following steps are required to set up the indicator.

- Inspect indicator to ensure good condition.
- Use connection diagrams to wire up load cell, power and auxiliary cables as required.
- Insert any accessory modules that are being used.
- Use the drill hole template provided for hole locations.
- Connect Power to indicator and press **<POWER>** key to turn the instrument On.
- Refer to the Setup Menus section on page 42 for information on configuring the instrument.
- To turn instrument OFF press and hold **<POWER>** key for three seconds (until display blanks).

### 3.2. General Warnings

- Indicator not to be subject to shock, excessive vibration or extremes of temperature (before or after installation).
- Inputs are protected against electrical interference, but excessive levels of electromagnetic radiation and RFI may affect the accuracy and stability.
- The instrument should be installed away from any sources of excessive electrical noise.
- The load cell cable is particularly sensitive to electrical noise and should be located well away from any power or switching circuits.
- For full EMC or for RFI immunity, termination of cable shields and correct earthing of the instrument is essential.

### 3.3. Electrical Safety

- For your protection all mains electrical hardware must be rated for environmental conditions of use.
- Pluggable equipment must be installed near an easily accessible power socket outlet.
- To avoid the possibility of electric shock or damage to the instrument, always switch off or isolate the instrument from the power supply before maintenance is carried out.

### 3.4. Cleaning

- To maintain the instrument, never use harsh abrasive cleaners or solvents. Wipe the instrument with a soft cloth **slightly** dampened with warm soapy water.

### 3.5. Panel Mount Template

The panel mount template is supplied with the instrument. It shows the location of the rectangular cut-out and the four mounting screws.

### 3.6. Cable Connections

All cable connections are made to the rear of the instrument using pluggable screw terminals. It is not necessary to tin the ends of the wires with solder or to add crimp ferrules to the wires, however, these techniques are compatible with the terminals.

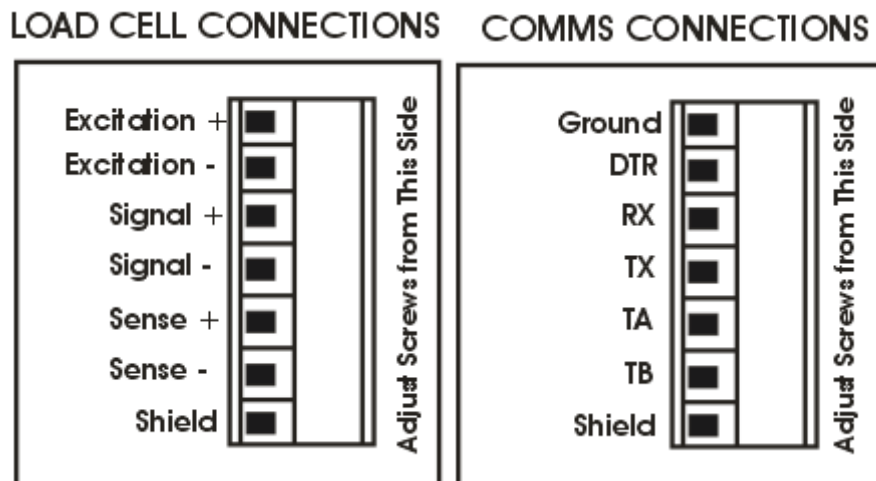

Figure 2: Cable Connections

### 3.7. DC Power (DC PWR + , DC PWR –)

The DC supply need not be regulated, provided that it is isolated and free of excessive electrical noise and sudden transients. The instrument can be operated from a high quality plug-pack as long as there is sufficient capacity to drive both it and the load cells.

### 3.8. Load Cell Connection

#### 3.8.1. Load Cell Signals and Scale Build

Very low output scale bases may be used but may induce some instability in the weight readings when used with higher resolutions. Generally speaking, the higher the output, or the lower the number of divisions, the greater the display stability and accuracy.

The instrument can display the millivolt-per-volt reading which can be used to check scale base signal output levels. For more information, refer to LC.HW MVV Display page 46.

The instrument may be connected for either 4-wire or 6-wire operation. Use 4-wire when external SENSE connections are not available.

#### 3.8.2. 4-Wire Connection

The minimum connectivity requirements are the connection of four wires (i.e.  $\pm$ Excitation and  $\pm$ Signal). Internally the instrument has a precision analog switch that can be used to connect the Sense+ and Sense– lines directly to the Excitation+ and Excitation– lines.

Any addition to the load cell manufacturer's cable length using 4-wire connection is only recommended for short cable runs. Where long additions to cable lengths are needed, a 6-wire extension is required.

The BUILD:CABLE option must be set to **4-WIRE** to allow for 4-wire connection.

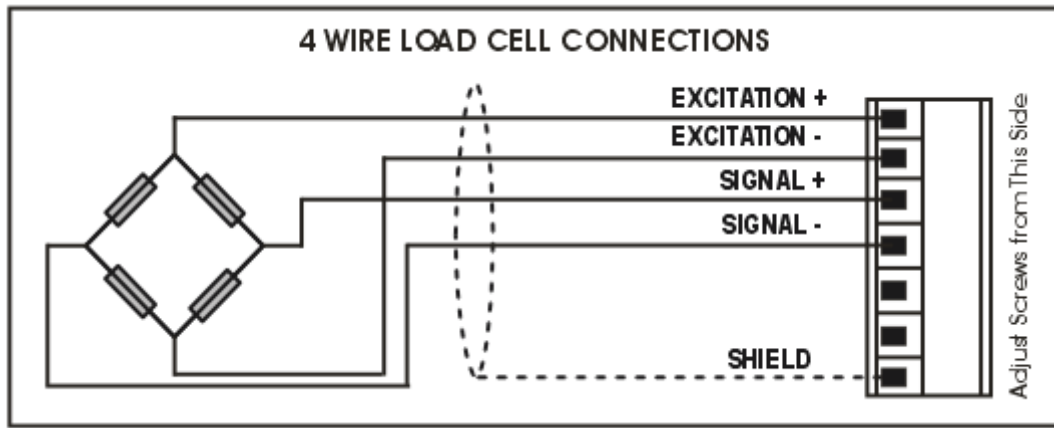

Figure 3: 4-Wire Connections

### 3.8.3. 6-Wire Connection

The excitation and signal lines are connected the same as for a 4-wire installation. The extra two wires (Sense + and –) should be connected to the Excitation + and – lines as close as possible to the load cell itself. Typically these connections are made in a load cell termination box. If the sense lines are not connected in 6 wire mode then E2000 will be shown.

The BUILD:CABLE option must be set to **6-WIRE** to allow for true 6-wire connection.

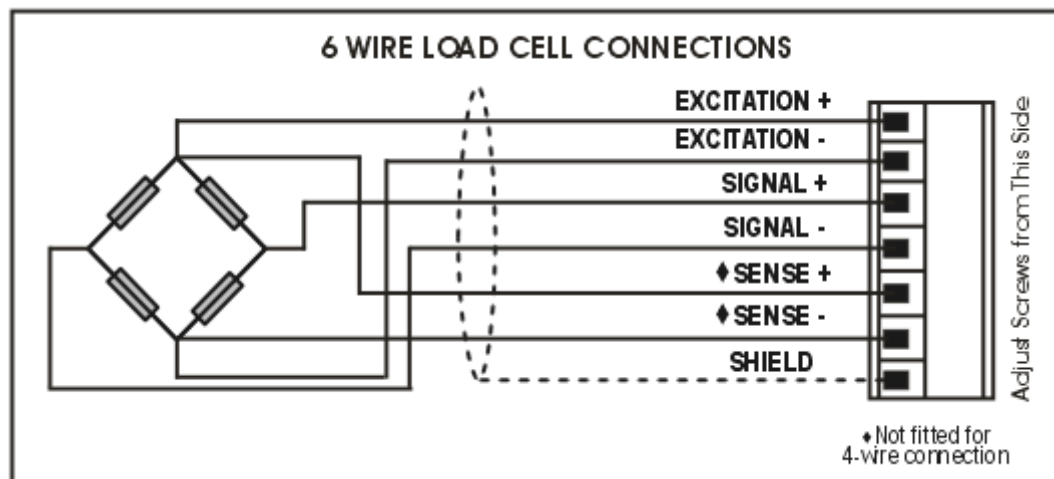

Figure 4: Loadcell Connections

### 3.9. Auxiliary Connections

This section provides diagrams to illustrate the communication connections.

### 3.9.1. RS-232 Serial

#### ◆ Direct Personal Computer Link (RX, TX, GND)

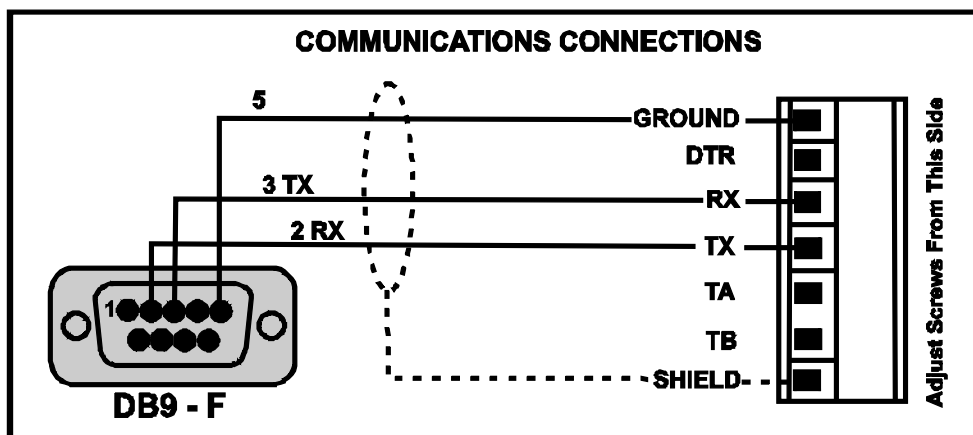

Figure 5: RS-232 - Instrument to PC using COM Port (DB9)

#### ◆ Printer Connections (TX, DTR and GND)

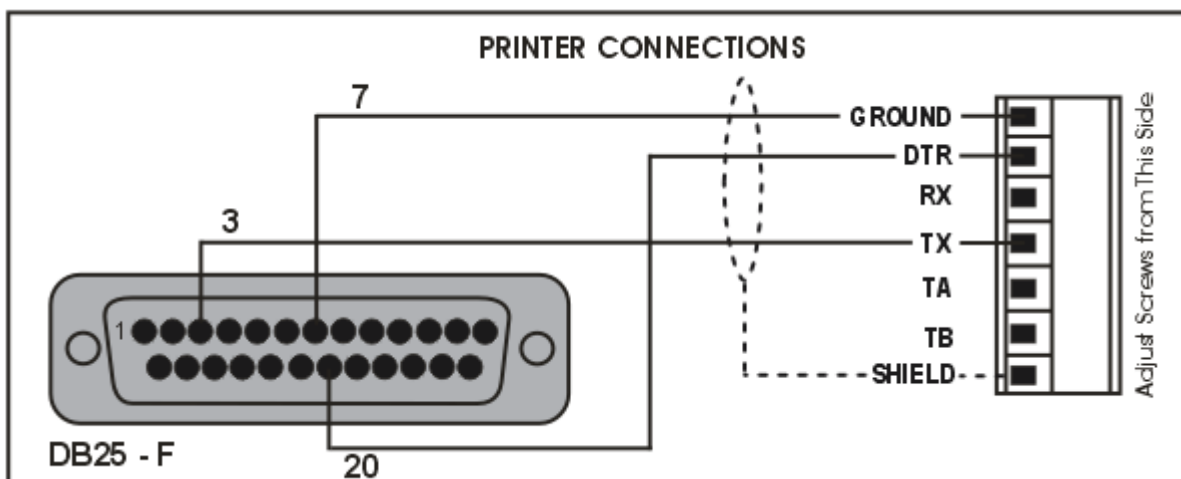

Figure 6: RS-232 – Instrument to Printer (DB25)

#### ◆ Remote Display (TXD, GND)

Refer to documentation supplied with the Remote Display for connection details. Connect RX on the Remote Display with TX on the instrument and connect the RS232 GND signals together.

#### ◆ Ring Networks: Multiple Instruments to PC (RXD, TXD, GND)

Instruments with software revision V2.31+ can be configured in a Ring Network via a M42xx module (software revision 1.01+). This feature is not available on the inbuilt serial port. This also requires an enhancement in the PC software.

The Short Ring Network layout (Figure 7) can be used in situations up to a total cable run length of about 150 m (500 ft) at 9600 baud in a clean EMC environment. If there are communications errors, or for longer cable runs, lower the baud rate to 4800 or 2400, and/or use the Long Ring Network in Figure 8, which uses a separate return path from the 'Last Instrument' to the PC.

For DB25 connections at the PC connector, refer to Figure 6.

When operating in a Ring Network, the Instruments must have:

- same serial port options, i.e., baud, parity, data bits, stop bits;
- unique addresses.

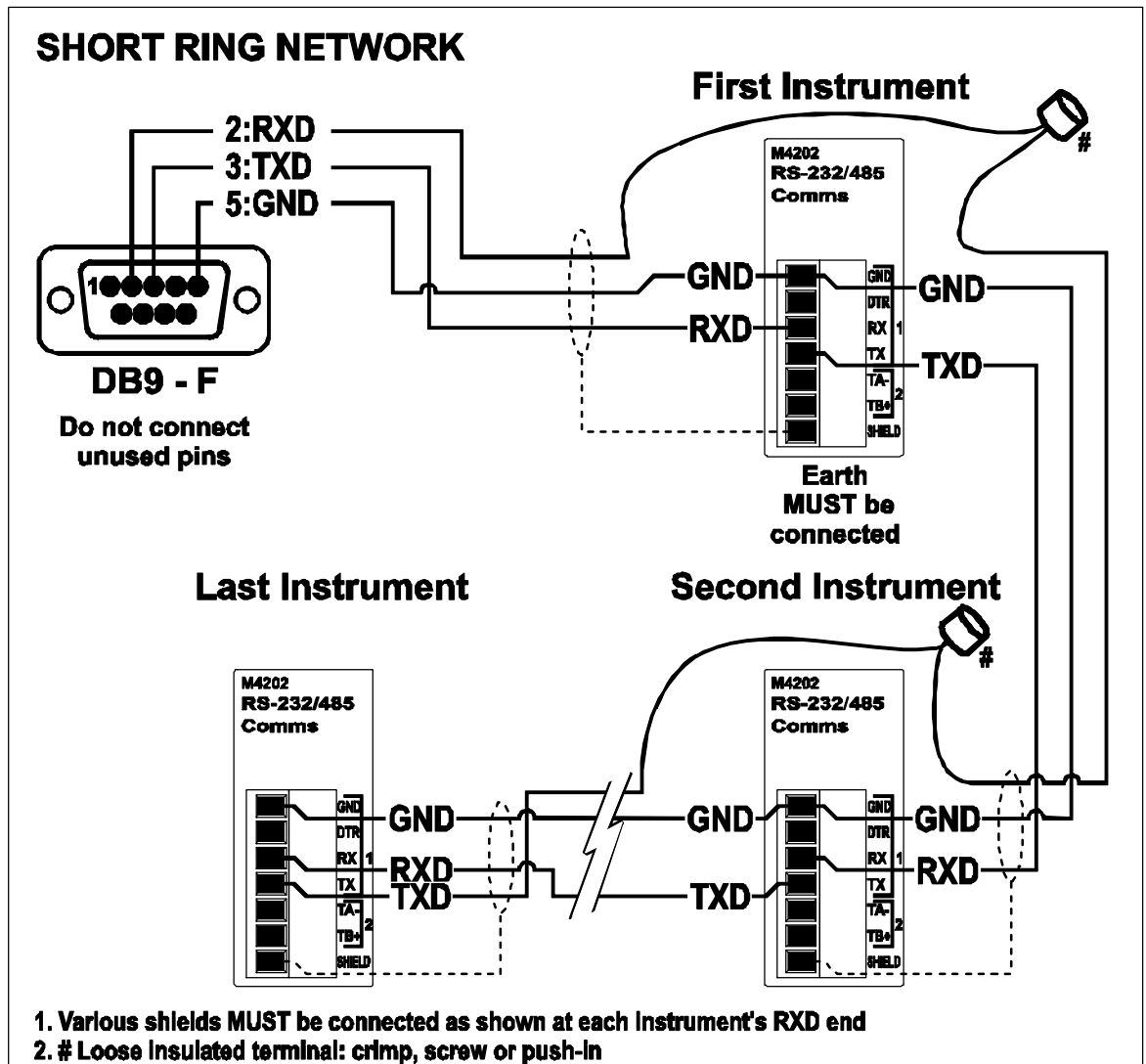

Figure 7: RS-232 Short Cable Runs (Ring Network using COM Port)

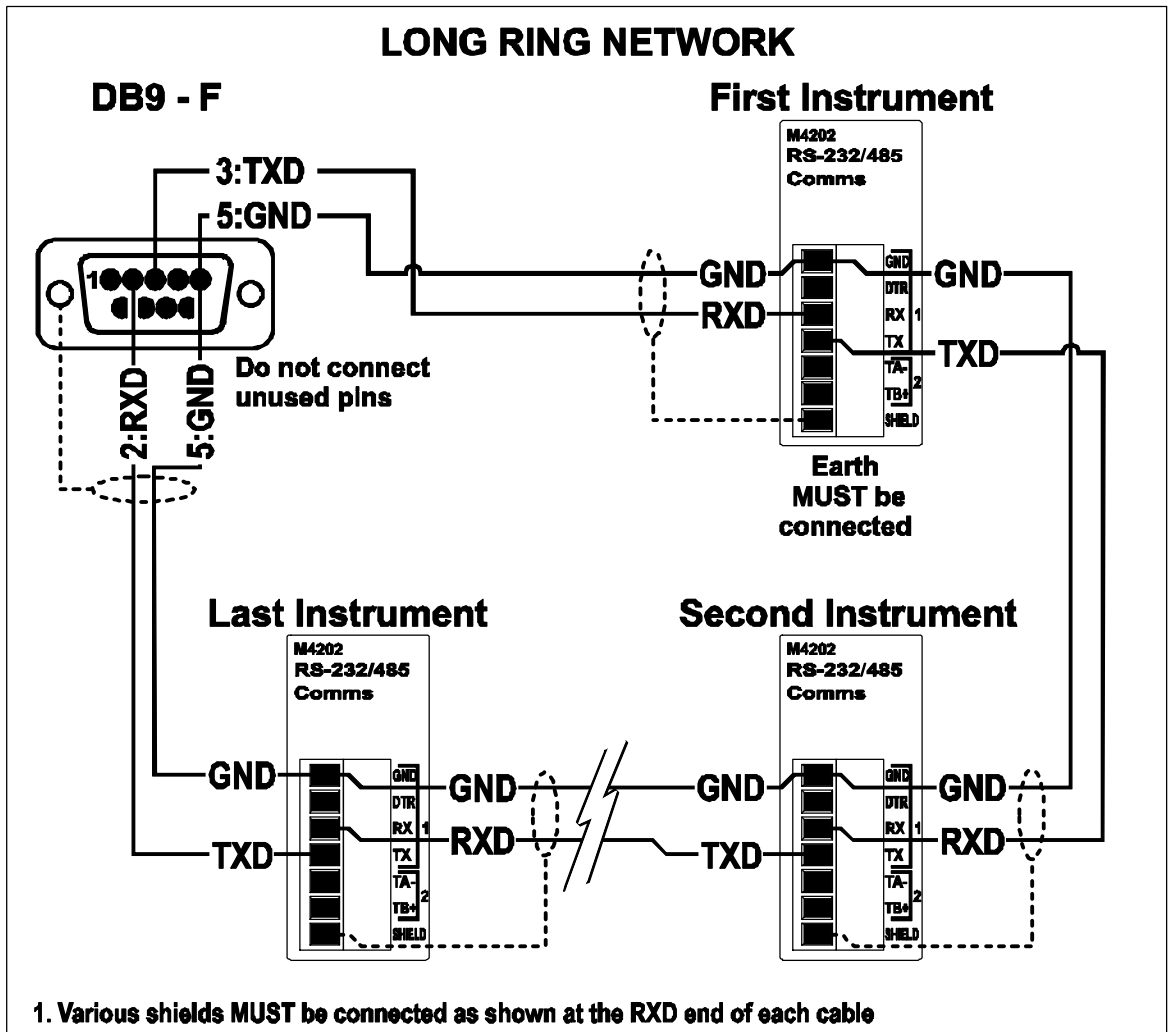

Figure 8: RS-232 Long Cable Runs (Ring Network using COM Port)

### 3.9.2. RS-485 Serial

◆ **Remote Display (TA, TB)**

RS485 is recommended for communicating over distances longer than a few metres. Connect TA to RA and TB to RB on the remote display.

◆ **Multi-drop Networks: Multiple Instruments to PC (TA, TB, RA, RB)**

Using a RS485 module it is possible to implement a multi-drop network.. This feature is not available on the inbuilt serial port.

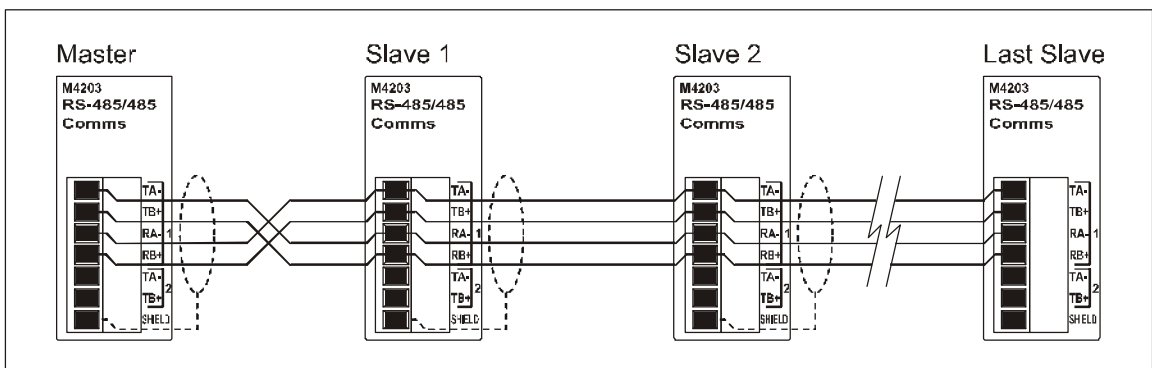

### ◆ Ring Networks: Multiple Instruments to PC (TA, TB, RA, RB)

Instruments with software revision V2.31+ can be configured in a Ring Network via a M42xx module (software revision 1.01+). This feature is not available on the inbuilt serial port. This also requires an enhancement in the PC software.

When operating in a Network, the Instruments must have:

- same serial port options, i.e., baud, parity, data bits, stop bits;
- unique addresses.

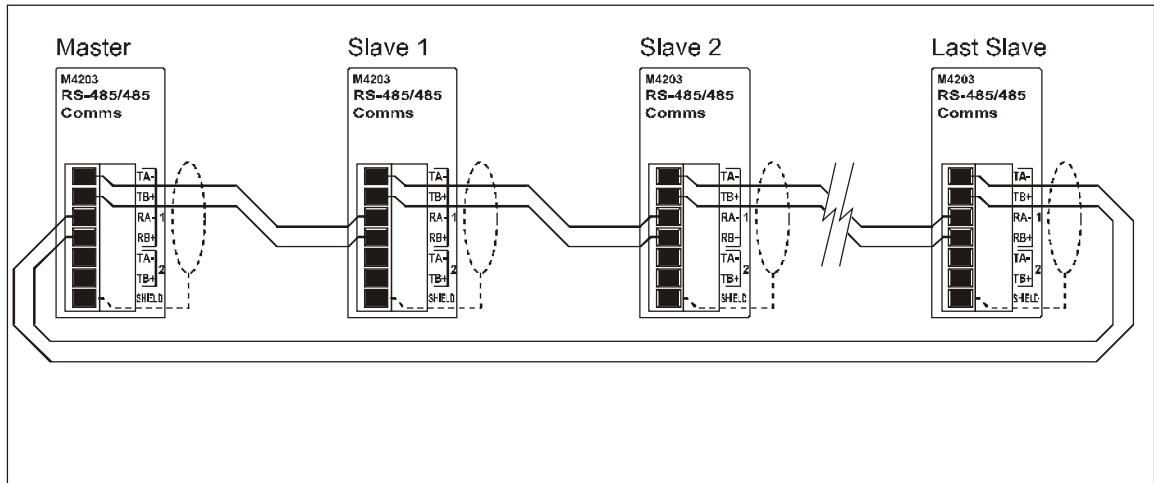

### 3.10. Optical Communications

A temporary infrared communications link can be established between the instrument and a PC using an optional cable. This connection can be used to transfer setup and calibration information from a PC or to download software upgrades.

The PC end of the cable is a standard USB or female DB9 RS232 connector. The instrument end of the cable attaches to the left side of the instrument display.

#### **WARNING**

**The optical coupling head contains a strong magnet and should not be placed near any magnetic storage media (eg. credit cards, floppy disks etc.)**

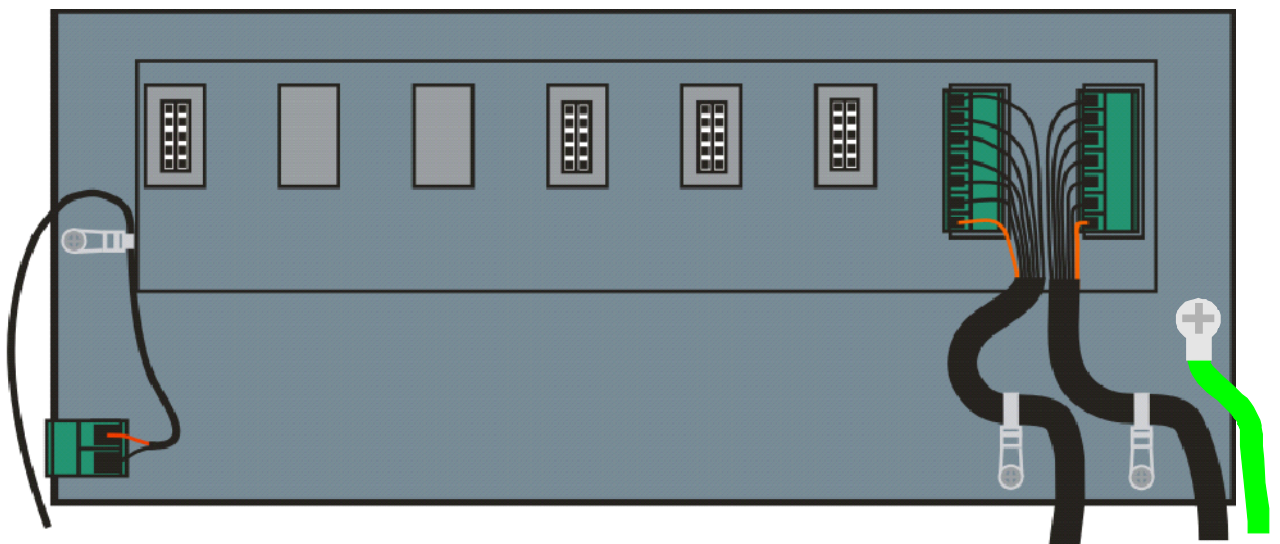

Figure 9: Optical Communications attachment

### 3.11. Connecting Shields

**To obtain full EMC or for RFI immunity, cable shields MUST be connected and the earth lug on the rear of the instrument must be grounded.**

Figure 10 illustrates an example of possible connections. Also shown are the connecting cables restrained using cable ties fastened by screws into the rear of the unit.



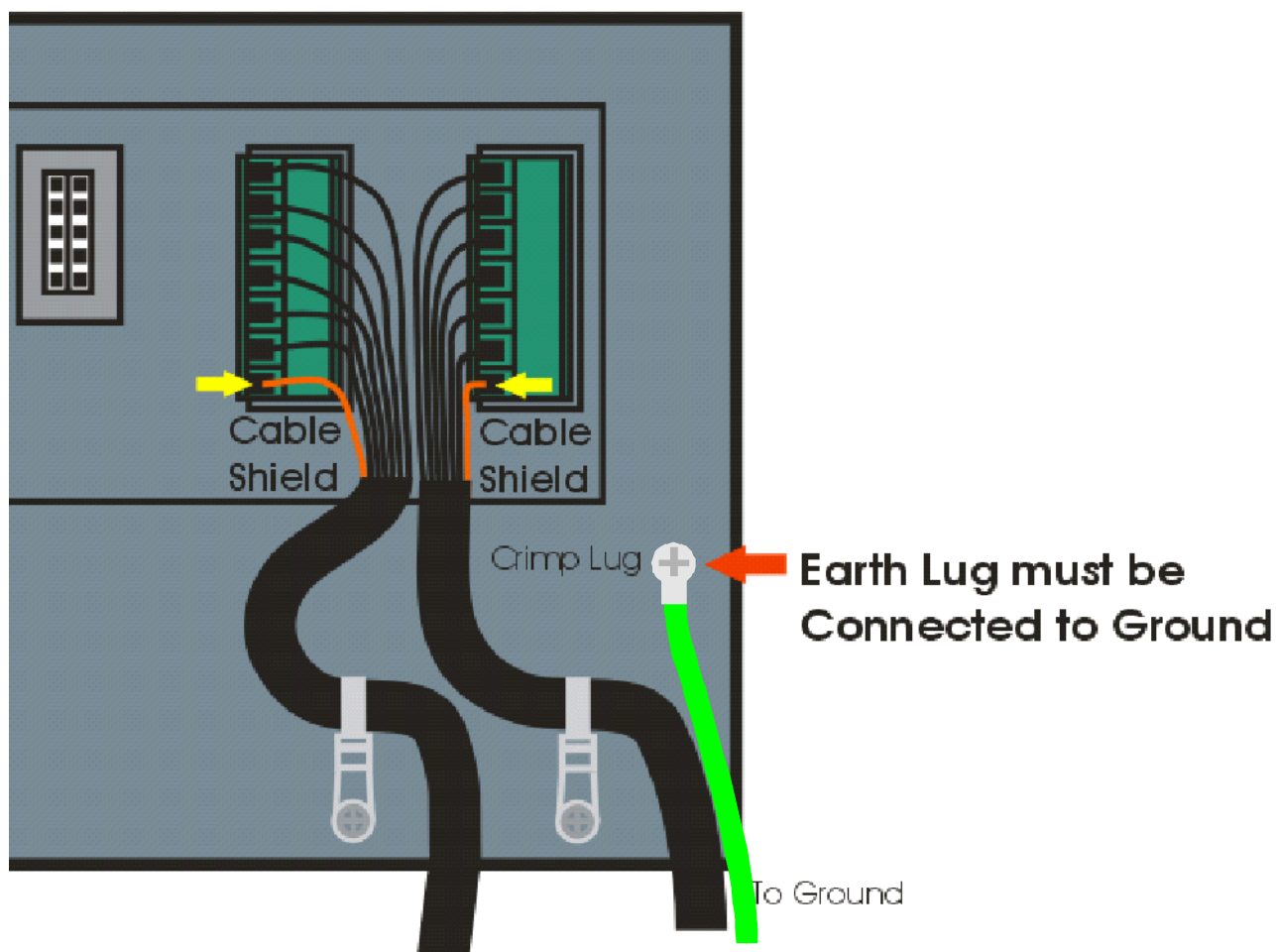

**Figure 10: Cable Shield Connection**

### 3.11.1. Cable Shield Connection and Earthing

- Care should be taken when connecting shields to maximise EMC or RFI immunity and minimise earth loops and cross-talk (interference) between instruments.
- For full EMC or for RFI immunity, termination of the cable shields to the connectors is very important. The earth lug of the instrument must be separately connected to ground potential via a reliable link.
- The AC power module directly connects the earth lug to the Earth Pin on the power supply. In installations where earth is available on the power cable, instrument earthing can be done with this connection.
- The instrument should only be connected to earth via a single reliable link to avoid earth loops.
- Where each instrument is separately earthed, interconnecting cable shields should be connected at one end only. This also applies to communications cable shields in Ring Networks, refer to Short Ring Network and Long Ring Network connections under Section 3.9.1 on page 12.
- **Caution:** Some load cells connect the cable shield directly to the load cell (and therefore the scale base). Connection of the load cell cable shield in this situation may be site specific.

### 3.12. Regulatory Sealing Requirements

To comply with regulatory sealing requirements for each instrument, (i.e. to ensure instruments are not accidentally or deliberately tampered with), it is important that proper sealing procedures be adhered to. Refer to Legal Sealing page 115 for more information.

### 3.13. Accessory Module connection

Up to 4 accessory modules can be plugged into the rear of the instrument. There are many types of modules which can be used. These modules provide additional features such as:

- power supply options, e.g. mains power or batteries
- communications ports, e.g. Ethernet or RS485 networking
- analogue outputs, e.g. 4-20mA or 0-10V
- digital inputs and digital outputs, e.g. external buttons or setpoint outputs
- Alibi memory, e.g. DSD functionality.

**Caution:** Instrument must be switched off before connecting or disconnecting accessory modules.

Each module will come with a manual which explains the features, installation and use of the module.

After connection, the module needs to be configured using the instrument setup menus. All hardware test functions and hardware options (such as serial baud rates or digital input debouncing) are in the H.WARE (hardware) menu described in section 0 page 46. Module resources (such as digital inputs or serial ports) are assigned in specific function menus. For example, the output used by a particular setpoint is set in the setpoint menu.

A summary of the module resource usage is available in the instrument setup menus. See ALLOC (Allocation Report) described in section 7.2.1 page 46.

Note: Power supply options can only be connected in the left position. Other modules can be connected in any position.

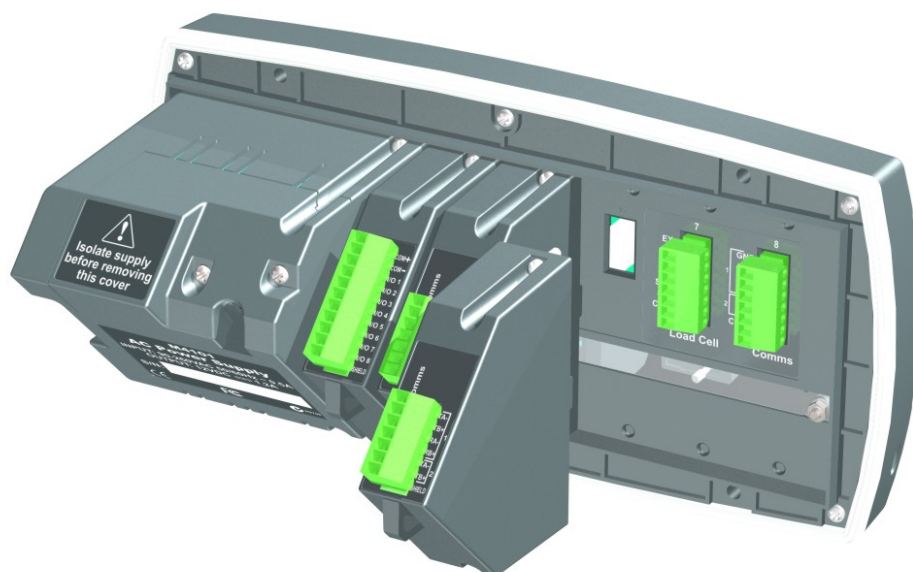

## 4. Setup Menus

Throughout the setup menus different data entry methods are used. Each method is described below.

### 4.1. Accessing Setup Menus



There are two methods to access the Setup area:

- The **Full Setup** method provides access to all functions in Setup, including legal for trade and calibration sensitive settings. Changes in Full Setup mode may result in the calibration counter being incremented. If an attempt is made to enter Full Setup using the incorrect passcode, the instrument will respond with the message **ENTRY DENIED**. Refer to Passcodes page 40 for more information.

**Full Setup**

There are 2 methods of accessing full setup:

1. Press and hold the **<POWER>** and **<F3>** keys together for two seconds, or

+

2. Press the setup button on the rear of the instrument.



### WARNING

All items in all menus will be enabled in **Full Setup**. Care should be taken to avoid inadvertently altering the Build or Calibration settings.

- **Safe Setup** restricts access to the Trade Critical settings. Changes made in this mode will not increment the calibration counter. In this manual, items marked with  $\ddot{A}$  indicate that the setting is trade critical. If an attempt is made to enter Safe Setup using the incorrect passcode, or if an attempt is made to alter a trade critical setting while in Safe Setup, the instrument will respond with the message **ENTRY DENIED**. Refer to Passcodes page 40 for more information.

**Safe Setup**

Press and hold both the **<POWER>** and **<ZERO>** keys together for two seconds.

+

**ZERO**

### 4.1.1. Setup Display Prompts

When accessing **Full** or **Safe Setup** the instrument will beep twice and enter the Setup Menus. If a passcode has been configured, the **P.CODE** prompt will display and the correct passcode must be entered to continue. Refer to Passcodes page 40 for more information.

If access is granted the following is displayed:

FULL (SAFE) → SETUP → Software Version (eg. V1.0) → Serial Number  
→ Calibration Counter (eg. C.00010).

(See Calibration Counter page 40 for more information)

### 4.2. Exiting Full or Safe Setup

To save settings, exit setup and return to the normal weighing mode use one of the following methods:

**Method 1:** Press and hold both the **<POWER>** and **<F3>** keys together for two seconds.

**Method 2:** Press and hold both the **<POWER>** and **<ZERO>** keys together for two seconds.

**Method 3:** Press the **<ZERO>** key repeatedly. When **End** displays press **<TARE>**.

**Method 4:** Press the **<POWER>** key.

The instrument will beep and then display the following:

Software Version (eg. V1.0) → Calibration Counter (eg. C.00010).

(See Calibration Counter page 40 for more information)

**Warning:** If the power is interrupted while in setup (i.e. by disconnecting the power cable), unsaved settings will be lost.

### 4.3. Menu Navigation

The setup menus are a normal menu tree structure. The current level is shown in the auxiliary display in the top right corner of the LCD.

Each level of the tree has its own key to step through the items in the menu. The 6 function keys correspond to the 6 menu levels with Zero for Level 1 through to F3 or level 6.

To access a lower level menu, use the key to the right of your current key. To return to the upper levels, use the keys to the left of your current key.

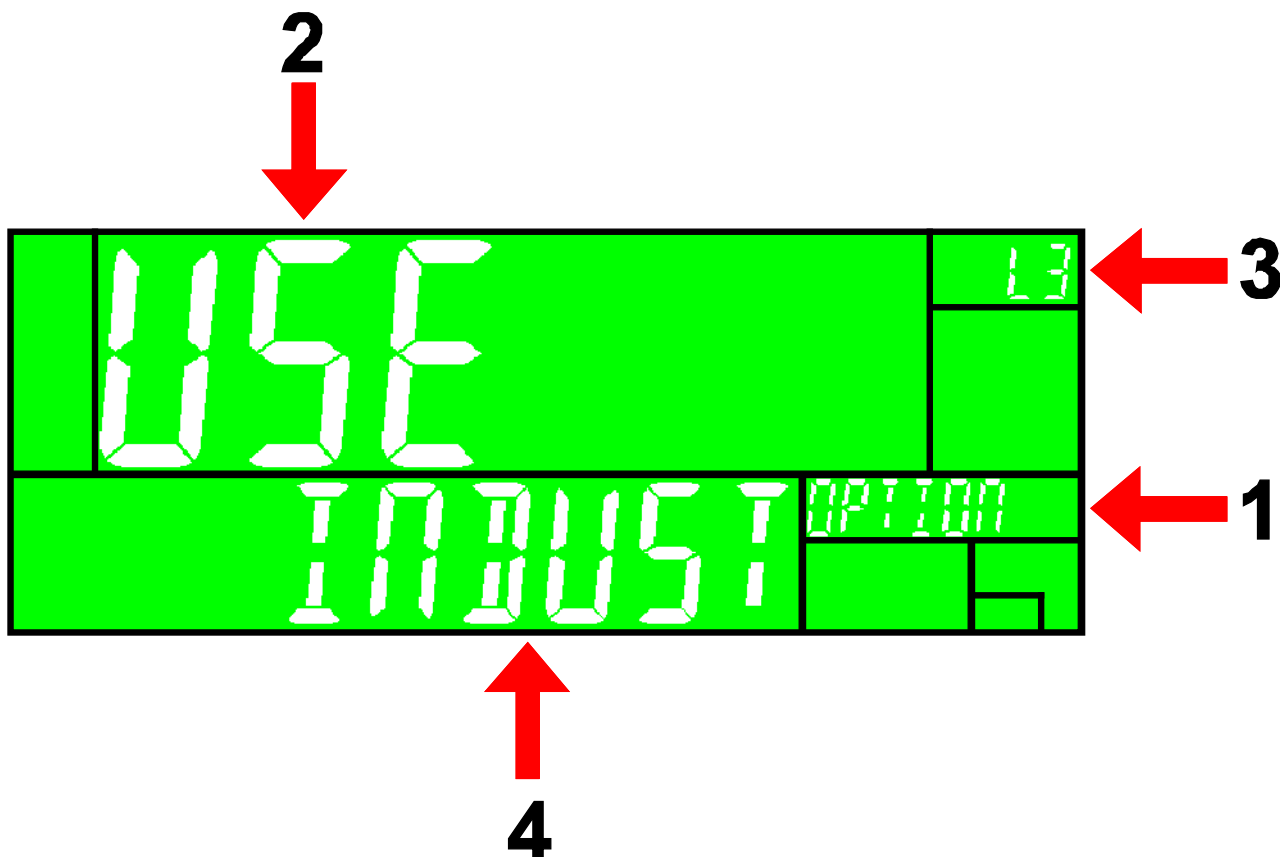

Code	Description
1	Parent Menu
2	Item Name
3	Menu Level
4	Item Data - If this is blank then the Item is a sub-menu.

#### 4.4. Changing Data

Menu items containing data are shown along with their data (strings may show the first few characters only). This data can be changed by using the editing keys. When editing is finished, press the OK key to accept the new data. If the new data is unwanted, press the cancel key (Sometimes several presses are required). While editing, the type of data being edited is shown in the top right corner of the LCD.

#### 4.5. Numeric Entry

Using the keypad, enter the desired number and press the OK key. Upper and lower limits are placed on some entries and an entry outside this range will cause the instrument to display dashes (i.e. - - - -). If the entered number is longer than the display then the display will scroll to show the newest entered digit, you can manually scroll with the arrow keys. Number entry/deletion is always at the least significant digit even if it is not currently displayed.

**Example:** When in Setup follow the steps below to set Scale:Build:Capacity 1.

Press <ZERO> repeatedly to display the <b>SCALE</b> menu.
Press <TARE> repeatedly to display the <b>BUILD</b> menu.
Press <GROSS/NET> repeatedly to display the <b>CAP1</b> item and the current setting (eg. 30.00kg).
Enter the new capacity using the keypad.
Press <OK>

## 4.6. Selections and Options

A selection entry requires the choice of a single option from a list.

Using the up and down arrows, select the desired option and press the OK key.

**Example:** When in Setup follow the steps below to set Scale:Build:Cable.

Press <ZERO> repeatedly to display the <b>SCALE</b> menu.
Press <TARE> repeatedly to display the <b>BUILD</b> menu.
Press <GROSS/NET> repeatedly to display the <b>CABLE</b> item and the current setting (eg. 4 WIRE).
Use the ↑ and ↓ keys to select the desired option from the list.
Press <OK>

## 4.7. Strings

There are 3 different methods of editing strings:

- Normal string editing (auxiliary display: STR)
- Numerical string editing (auxiliary display: S.NUM)
- ASCII string with character position (auxiliary display: S.ASC)

Use the <+/-> key to cycle between these options.

### 4.7.1. Normal String Editing

Normal string editing is most useful where strings are small and contain no lowercase or unprintable characters. The available characters are printed in orange on the keypad.

Special keys are:

- <OK>: Accept changes and finish.
- <Long press of cancel>: Cancel and exit without changes
- <Cancel>: Delete character
- <Up>, <Down>: Move cursor
- <Long press of down>: Delete string after cursor
- <+/->: Switch editing modes

### 4.7.2. Numerical String Editing

Numerical string editing is useful where strings only contain numbers.

Special keys are:

- <OK>: Accept changes and finish.
- <Long press of cancel>: Cancel and exit without changes
- <Cancel>: Delete character
- <Up>, <Down>: Move cursor
- <Long press of down>: Delete string after cursor
- <+/->: Switch editing modes

### 4.7.3. ASCII String Editing

ASCII string editing is useful where tokens or other unprintable characters are required. ASCII codes are entered as numbers. Print tokens are entered in this mode.

Special keys are:

- <OK>: Accept ASCII code/Accept changes and finish.
- <Long press of cancel>: Cancel and exit without changes
- <0> to <9>: Enter a new code
- <Cancel>: Delete character
- <Up>, <Down>: Move cursor
- <Long press of down>: Delete string after cursor
- <+/->: Switch editing modes

## 4.8. IP Addresses

An IP (internet protocol) address entry is used to enter the four decimal octets separated by a full stop that make up an IP address. IP addresses are entered in the form “xxx.xxx.xxx.xxx”, for example “192.168.100.1”.

Using the keypad, enter the desired IP address and press the OK key. Limits are placed on entries and an entry outside this range will cause the instrument to display dashes (i.e. - - - -).

## 5. Basic Operation

### 5.1. User Interface Display and Controls

#### 5.1.1. Overview

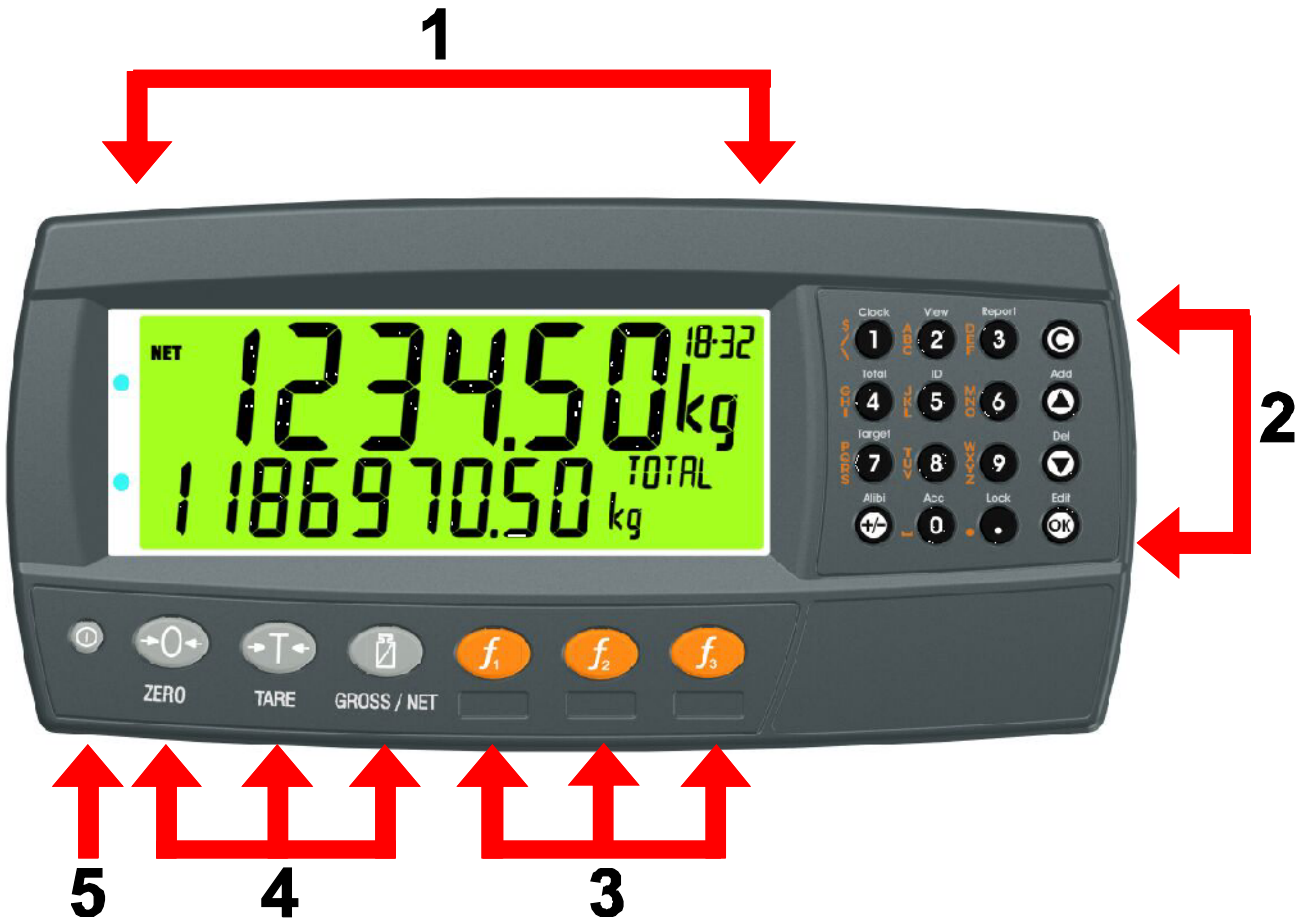

Code	Description
1	Display
2	Numeric Keypad
3	Function Keys (user defined)
4	Function Keys (Fixed)
5	Power Key

## 5.1.2. Display

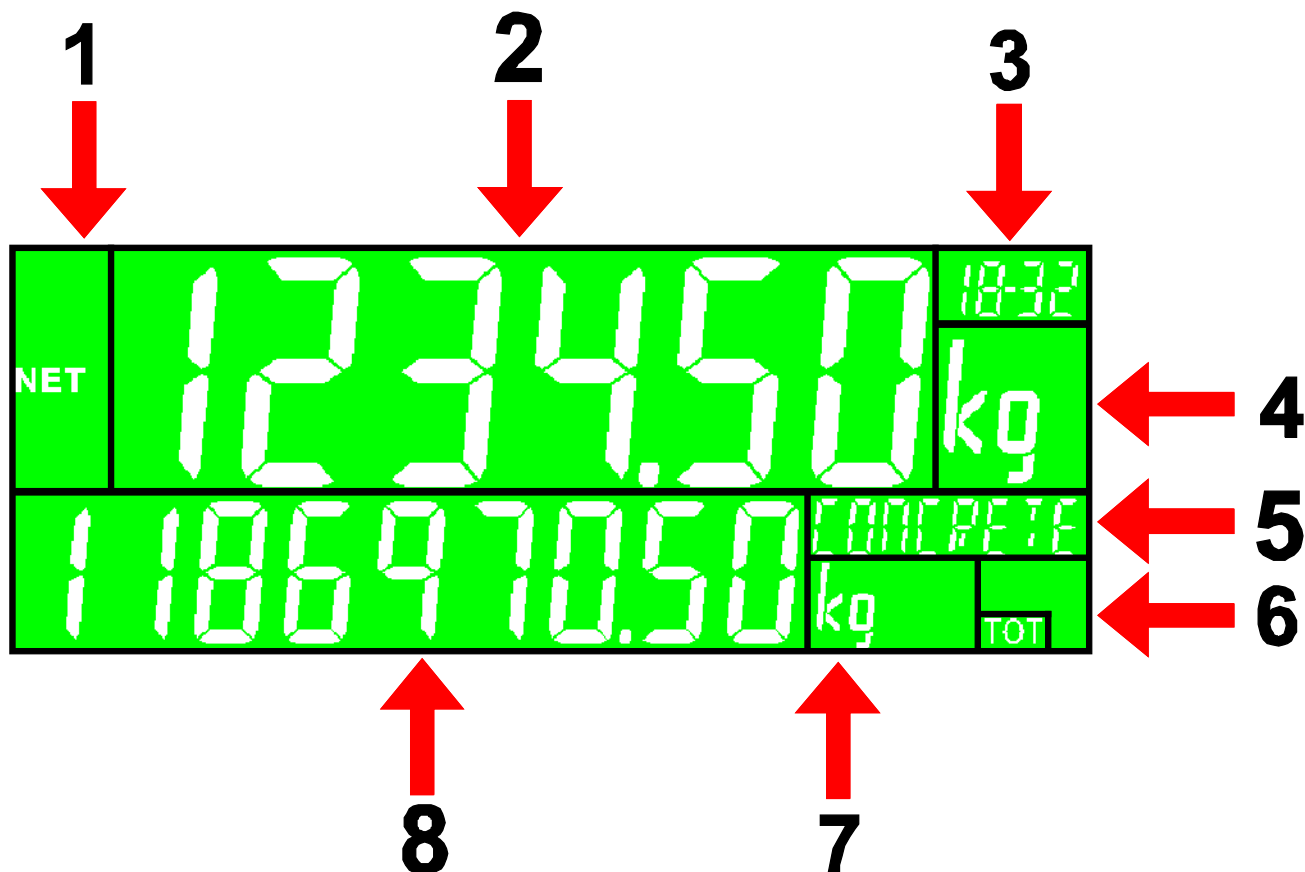

Code	Description
1	Primary Annunciators
2	<b>Primary Display</b>
3	Auxiliary Display
4	Primary Units
5	<b>Secondary ID</b> Eg Product Name = CONCRETE in example above.
6	Miscellaneous Annunciators
7	Secondary Units
8	<b>Secondary Display</b>

## 5.1.3. Primary Annunciators

Symbol	Name	Description
<b>HOLD</b>	HOLD	Visible when the displayed reading is held.
<b>NET</b>	NET	Visible when the displayed reading represents Net weight.
<b>→0←</b>	ZERO	Visible when the gross reading is within $\pm \frac{1}{4}$ of a division of true zero.
<b>~</b>	MOTION	Visible when the displayed reading is not stable.
<b>[ ]</b>	ZERO BAND	Visible when the displayed weight is within the zero 'dead' band setting.
<b>←   →</b>	RANGE	Indicates current range (for dual range/interval).



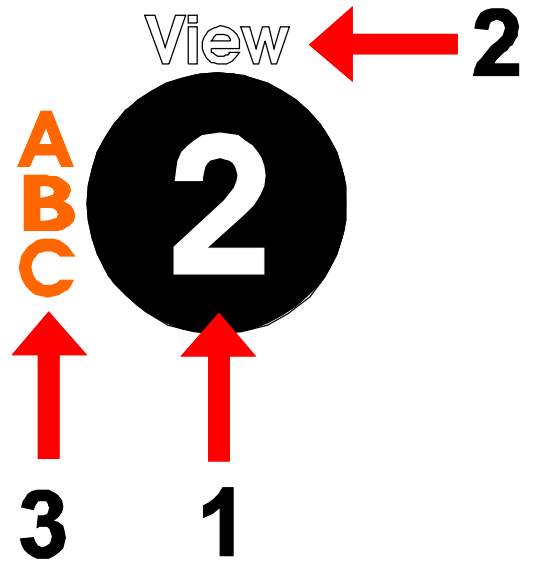

5.1.4. Keypad



Code	Description	
1	Numeric Button	0-9
2	White Characters	Hold 2 seconds
3	Orange Characters	(Alpha and Symbols)
	Cancel	Undo last command; step backwards (including in setup menus).
	Up	Move cursor backwards; previous option
	Down	Move cursor forwards; next option
	OK	Accept this choice
	Decimal Point	Place decimal point
	+/-	Change to negative or positive number; Change Editing VIEW (eg ASCII vs string)

## 5.2. Operation Keys

Legend:

	Press		Single beep
	Press and hold		Double beep
	Display flashing		

## 5.2.1. Power Key

## ◆ ON Instrument

(1) Short press &lt;Power&gt;.

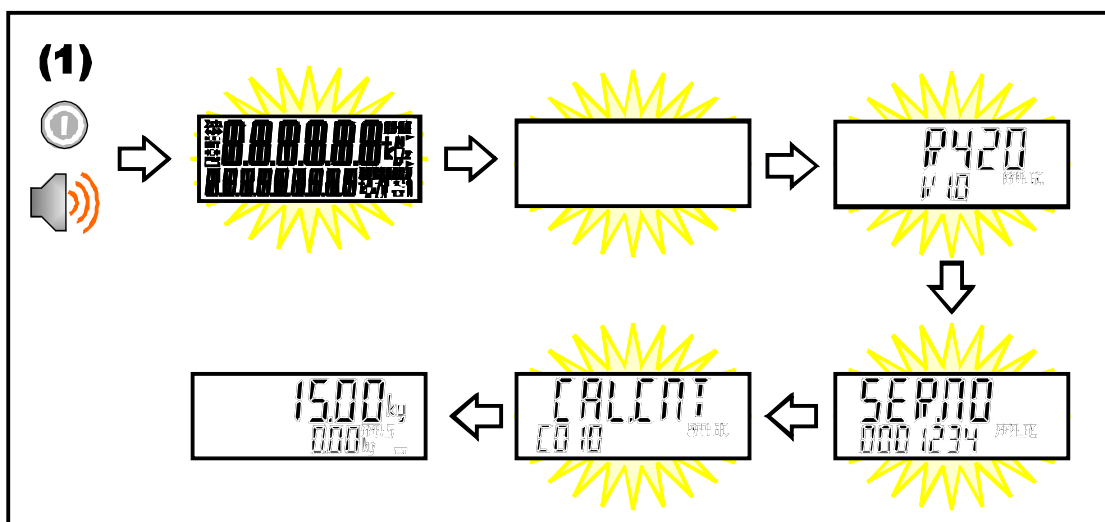

## ◆ OFF Instrument

(1) Long press &lt;Power&gt;.

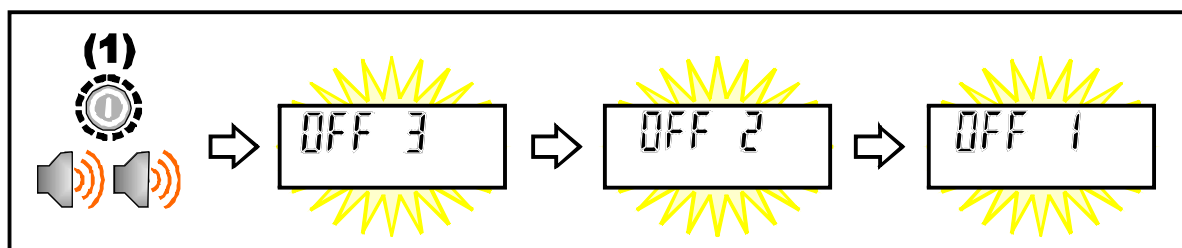

## ◆ Additional Information

**Power Key Locked:** If the power key is locked, the Instrument cannot be turned off from the front keypad.

**Automatic Operation:** Instrument will operate whenever external power is available and will not need to be manually turned on again if the power is interrupted.

### 5.2.2. Zero Key

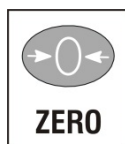

When an empty scale has drifted away from a true zero reading, this key is used to perform a zero adjustment on the scale display. The zero adjustment is stored when power is removed and is re-used when next powered up.

The amount of weight that may be cancelled by the <ZERO> key is limited by the Z.RANGE setting (7.3.2 OPTION (Scale options)7.3.2, p52).

#### ◆ Short Press

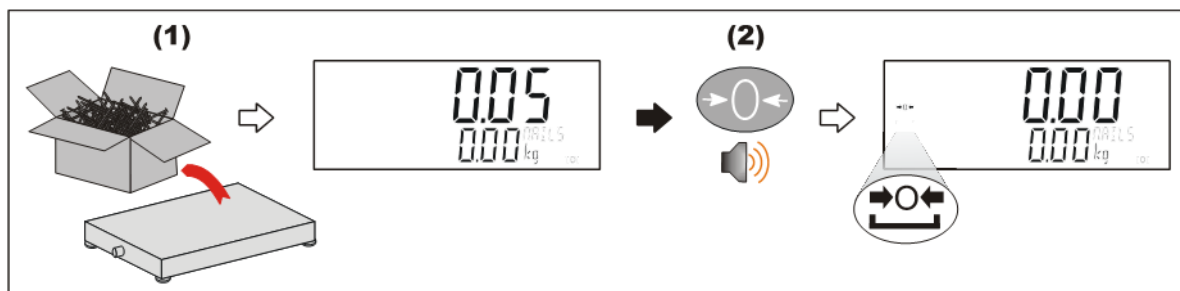

### 5.2.3. Tare Key



This key is used to temporarily set the scale to zero (such as cancelling the weight of a carton before performing a filling operation). The display will show the Net weight and the NET annunciator will be lit.

The weight tared is deducted from the allowable range of the scale, reducing the maximum weight that can be displayed.

**Preset Tare:** Preset Tare values are entered using the Numeric Keys followed by the TARE key. (E.g. to enter 1.5kg as a preset tare, press <1> <.> <5> <TARE>)

The tare adjustment is stored when power is removed and is re-used when next powered up.

#### ◆ Short Press

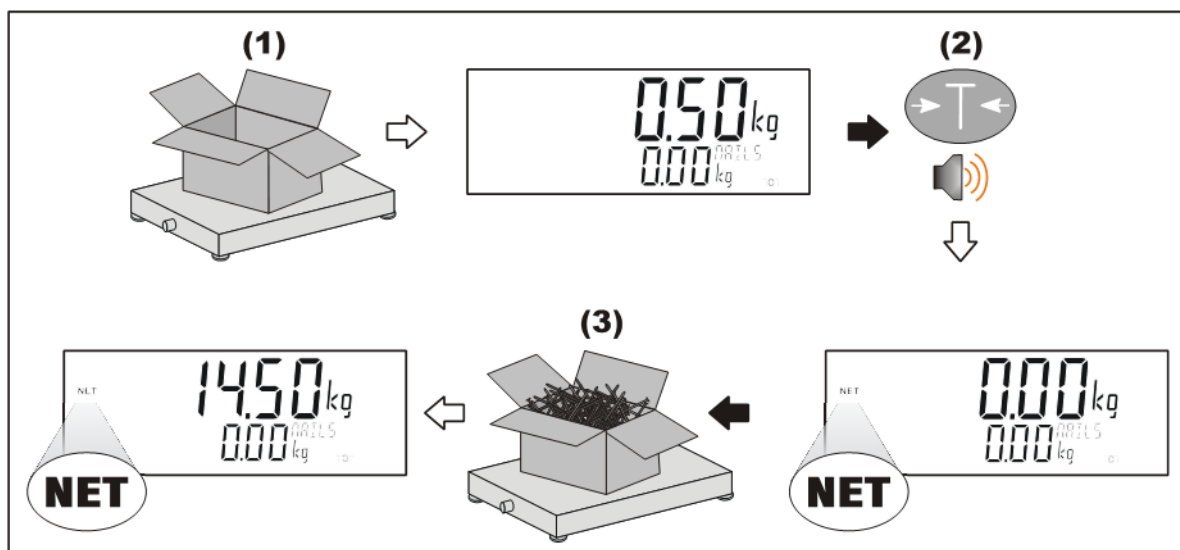

◆ **Setting Preset Tare**

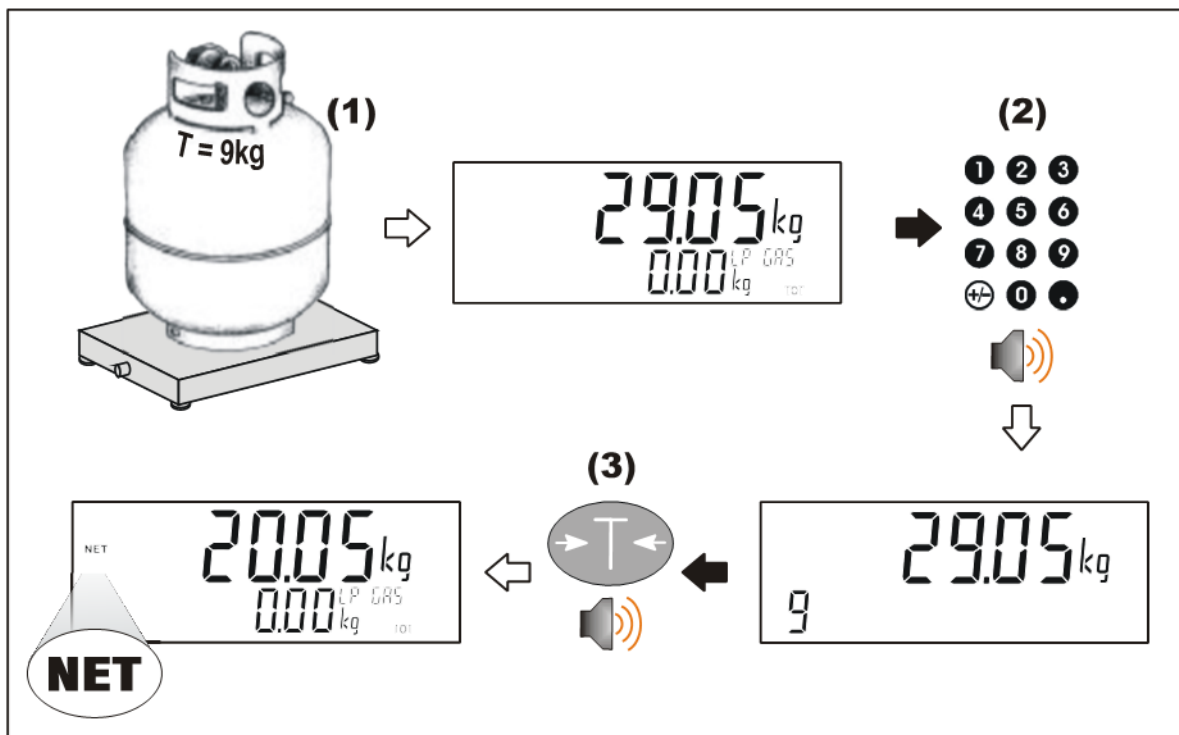

◆ **Displaying Preset Tare**

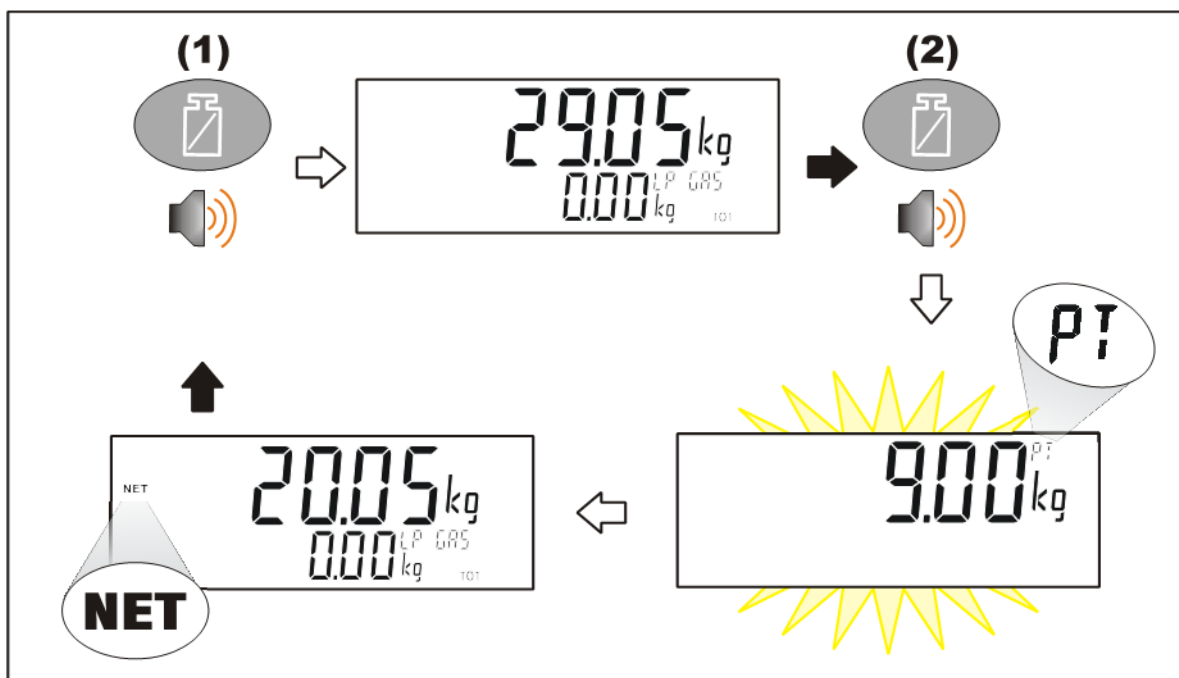

### 5.2.4. Gross/Net Key

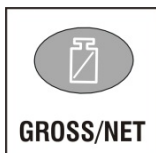

This key toggles the weight display between the Gross weight and the Net weight (provided that a Tare has previously been acquired using the <TARE> key).

If a preset Tare has been entered, the value of the preset Tare will be temporarily displayed when switching from Gross to Net display.

#### ◆ Short Press

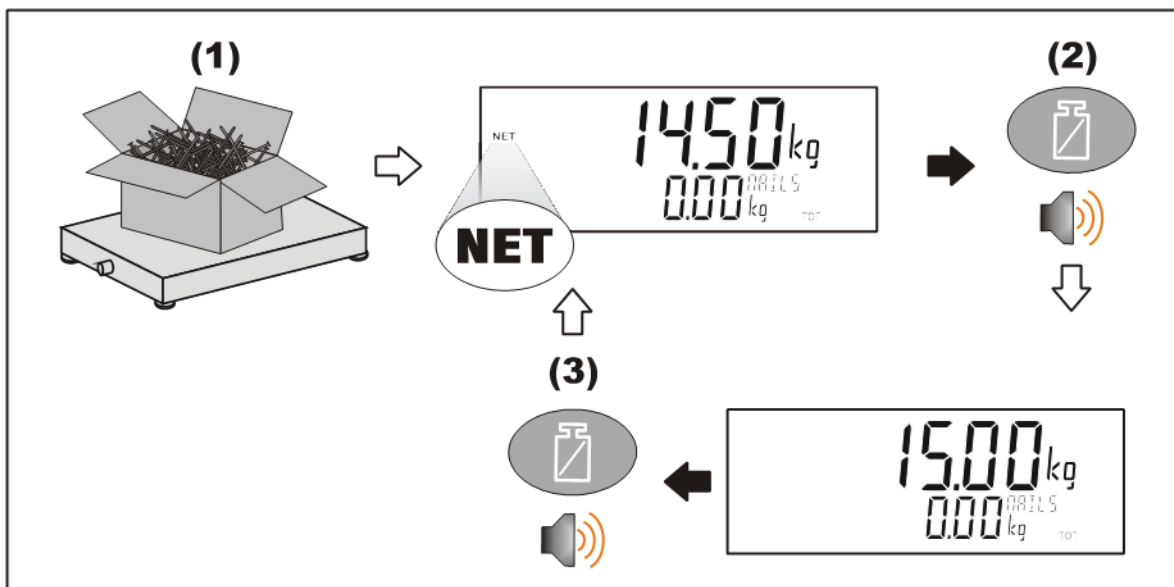

### 5.2.5. Function Keys

 <input type="text"/>	 <input type="text"/>	 <input type="text"/>	<ul style="list-style-type: none"> <li>• Functions are set in the FUNC menu.</li> <li>• Function key labels are attached below the key.</li> <li>• See Special Functions section 12 for a description of operation.</li> </ul>
--------------------------	--------------------------	--------------------------	--

### 5.2.6. Up, Down, OK keys: Products (K402, K403 and K491 only)

These keys are used to control the products. A short press of <UP> and <DOWN> keys is used to select products. A long press of the <UP> key will add new products. A long press of the <DOWN> key will delete products. A long press of the <OK> key will edit the name of the current product.

#### ◆ Short Press of Up and Down keys

A short press of these keys will allow the user to select the desired product from a list of the most recently used. The keypad can be used to enter the first letter of the product name. The <UP> and <DOWN> keys will then step through the list of product starting with the entered letter.

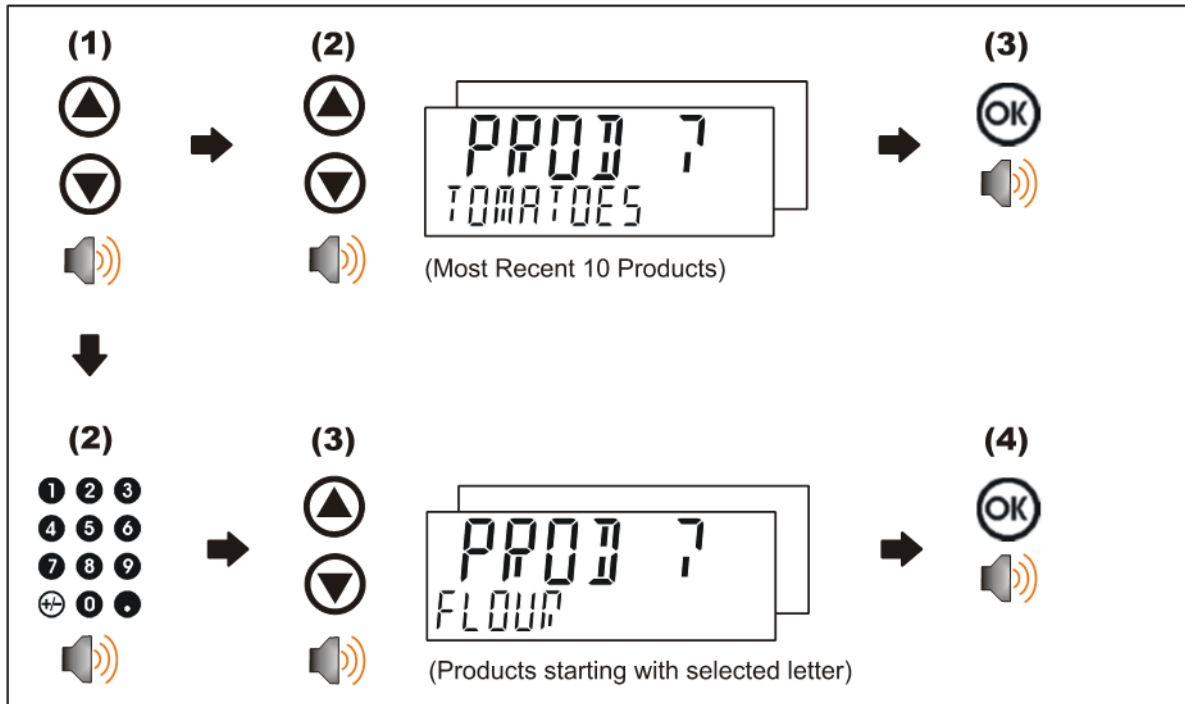

◆ **Long Press of the Up Key (Add)**

A long press of this key allows the user to create a new product. The name of the new product must be specified.

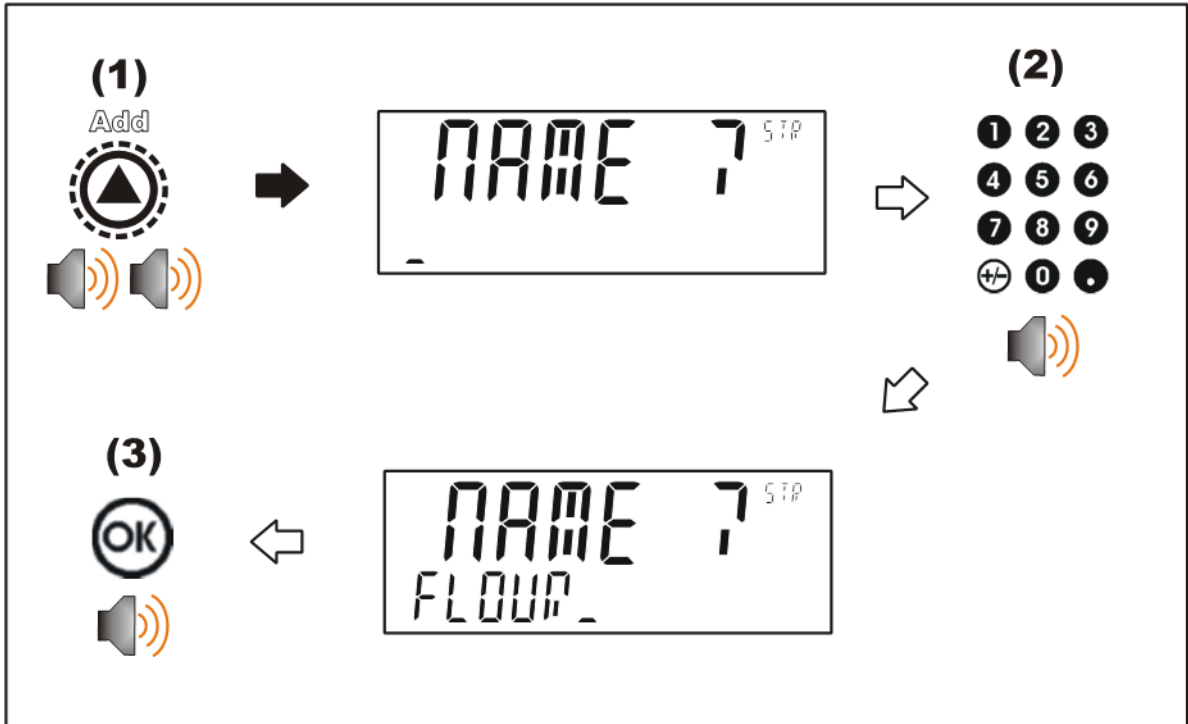

◆ **Long Press of the Down Key (Del)**

A long press of this key will prompt the user to delete all products, if the user presses the cancel key it will then prompt the user to delete the current product. Products can only be deleted if the total weight is 0. Product totals can be cleared using a long press of the 4 key (Total).



◆ **Long Press of the OK Key (Edit)**

A long press of this key allows the user to change the name of the current product.

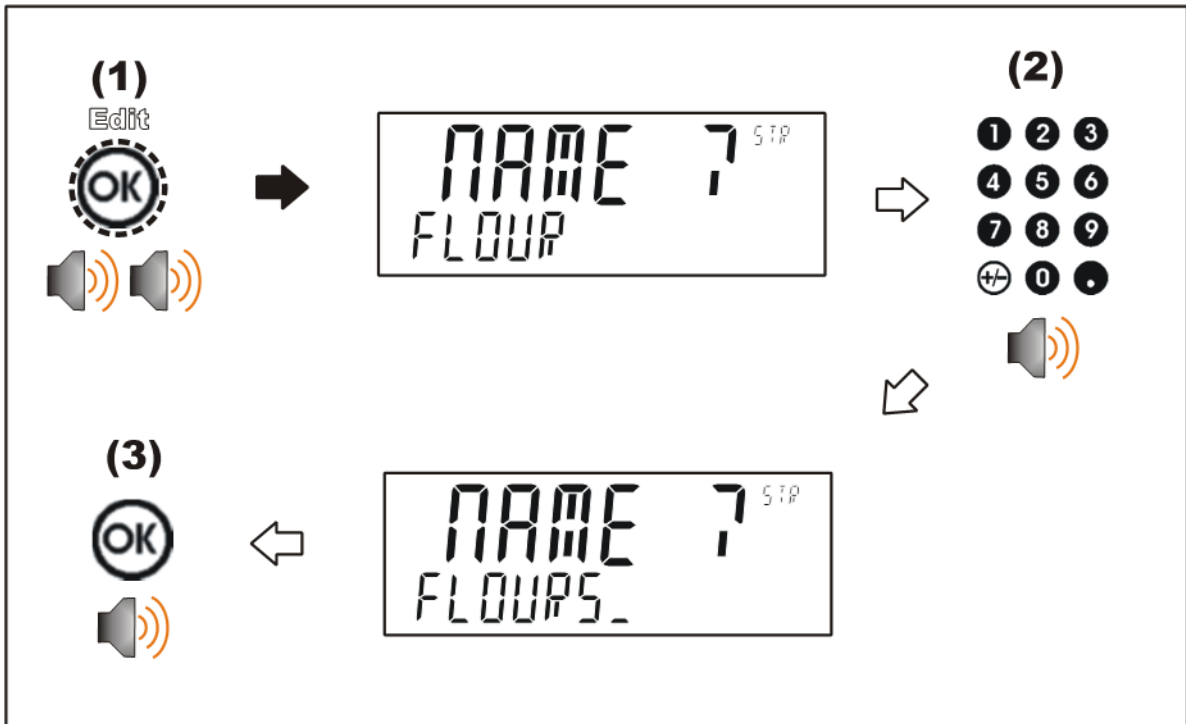

**5.2.7. Clock**

A long press of the 1 key (Clock) allows the system time and date to be viewed and changed

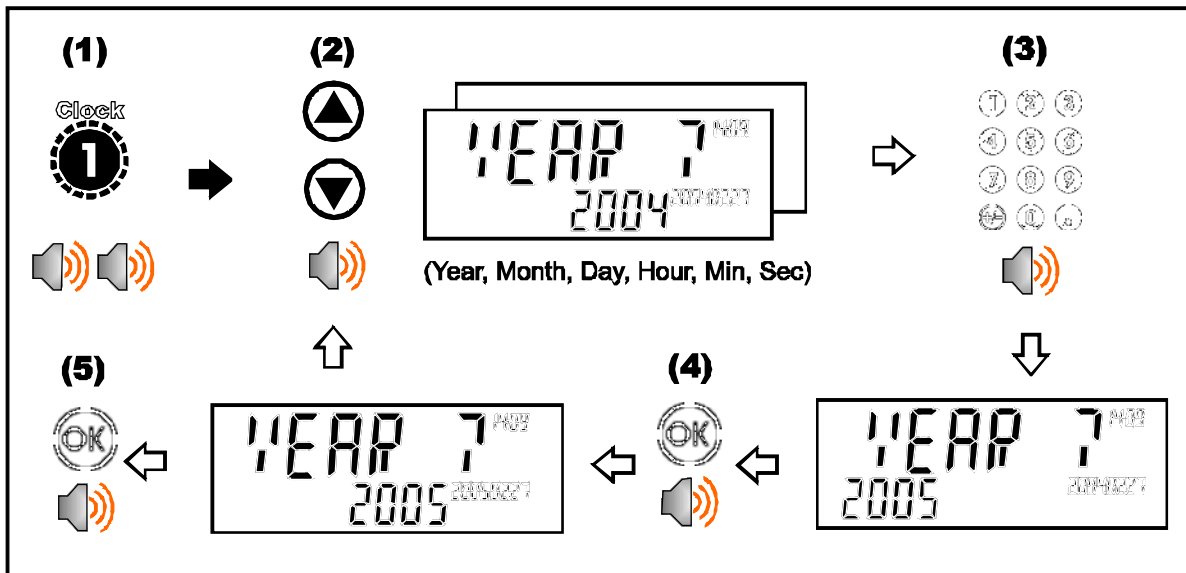

### 5.2.8. View

A long press of the 2 key (View) allows the display function to be changed.

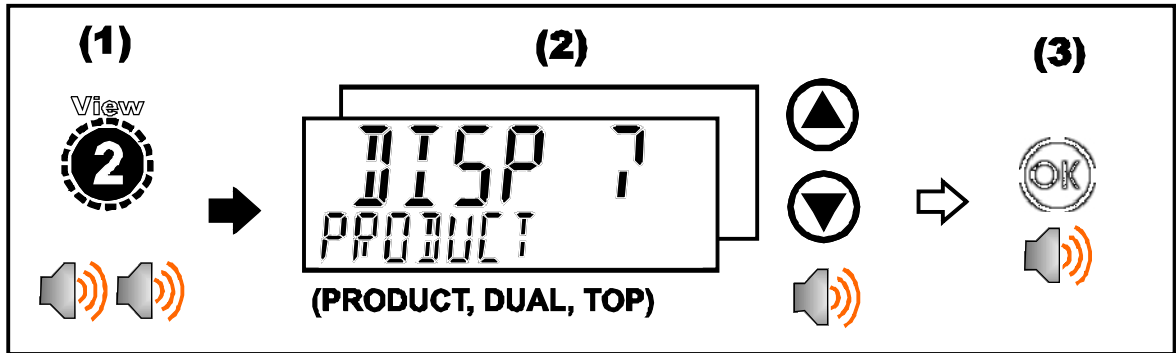

### 5.2.9. Report

A long press of the 3 key (Report) allows any configured reports to be printed.

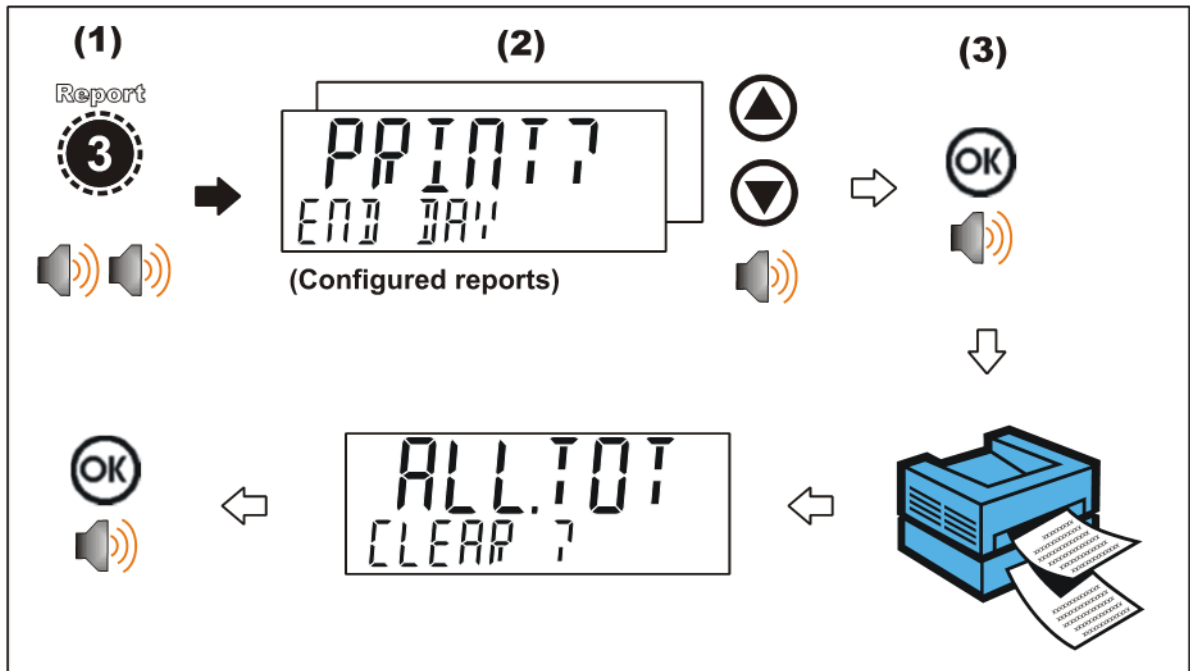

5.2.10. Total

A long press of the 4 key (Total) allows totals to be viewed and cleared.

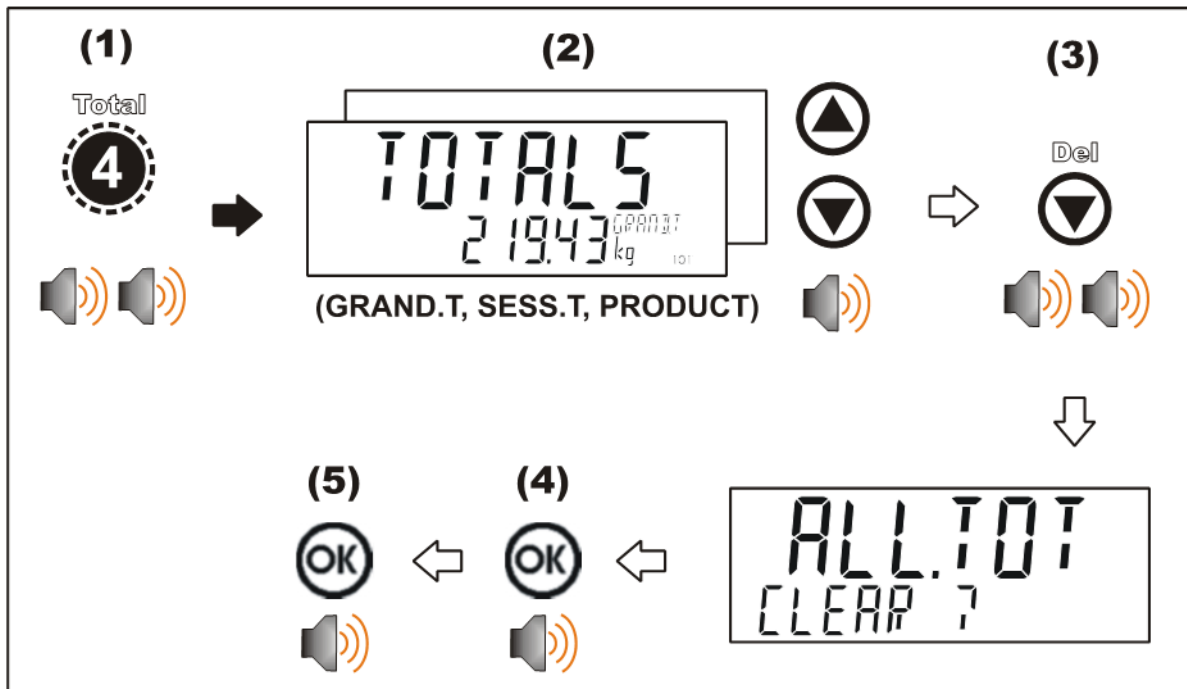

5.2.11. User ID

A long press of the 5 key (ID) allows User IDs to be viewed and cleared. The Settable Consecutive Print ID can also be viewed and edited, refer also to 11.2 Print ID page 89. The product barcode field is also able to be viewed and edited.

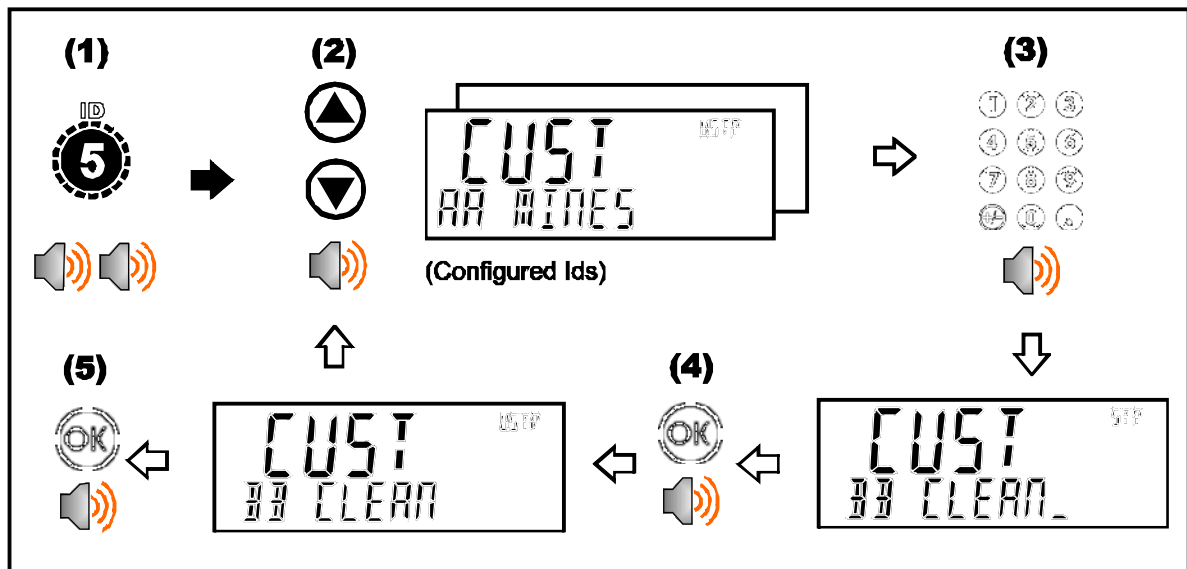

### 5.2.12. Target

A long press of the 7 key (Target) allows setpoint targets to be viewed and changed.

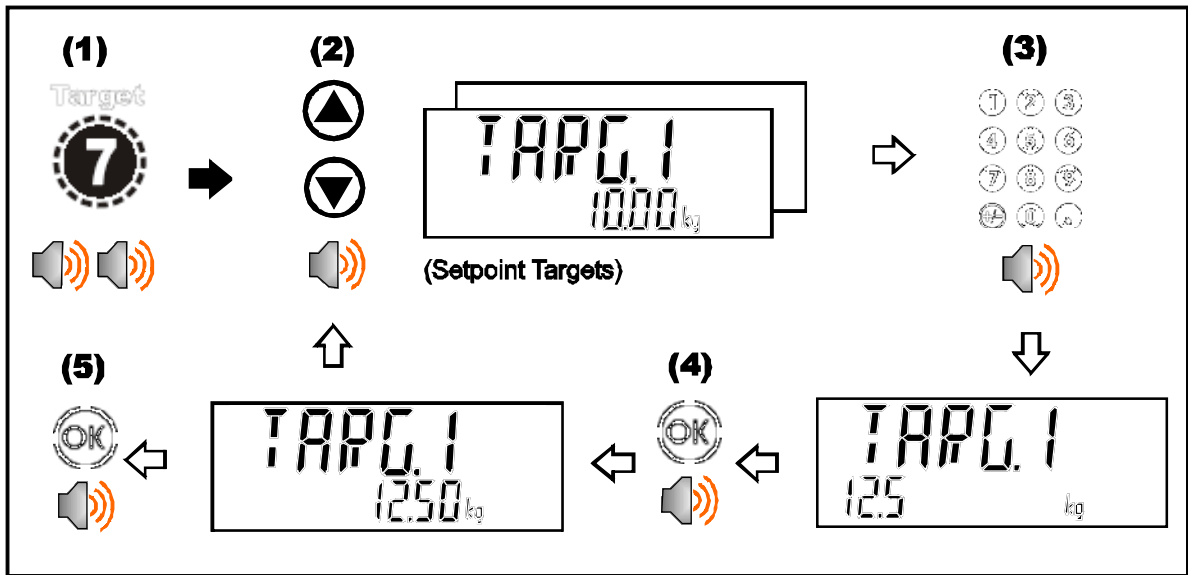

### 5.2.13. Lock

A long press of the . key (Lock) allows instrument to be locked. The instrument can be unlocked by entering the operator passcode when prompted.

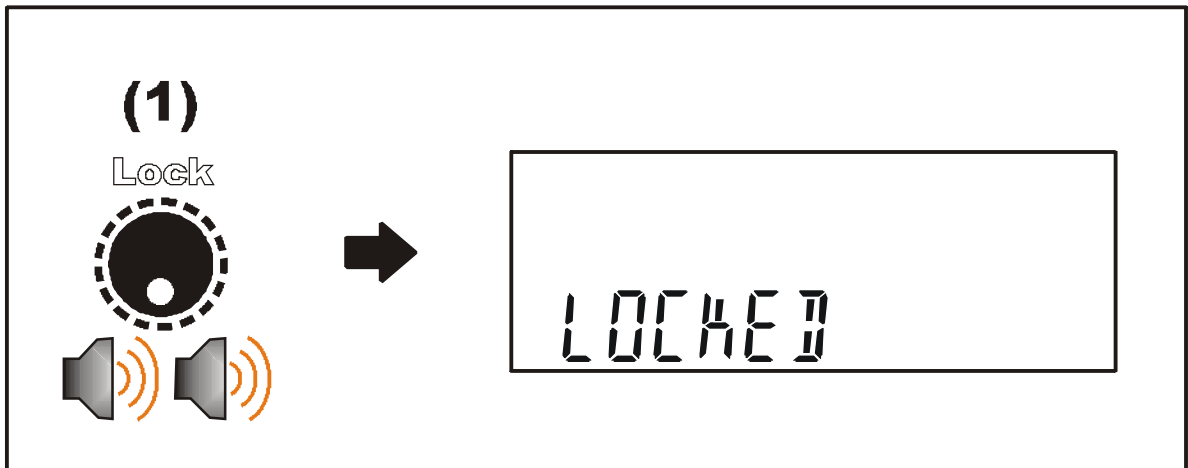

### 5.2.14. Alibi

A long press of the +/- key (Alibi) will switch the instrument to Alibi mode. Alibi mode is used to verify scale readings. To return from Alibi mode, long press the +/- key (Alibi) again.

#### ◆ Switching to Alibi Mode

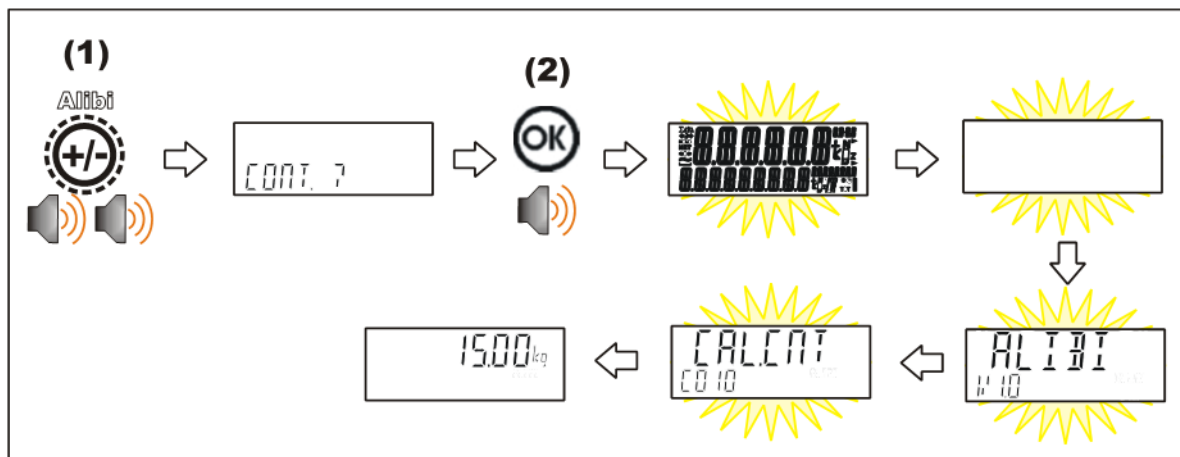

#### ◆ Returning from Alibi Mode

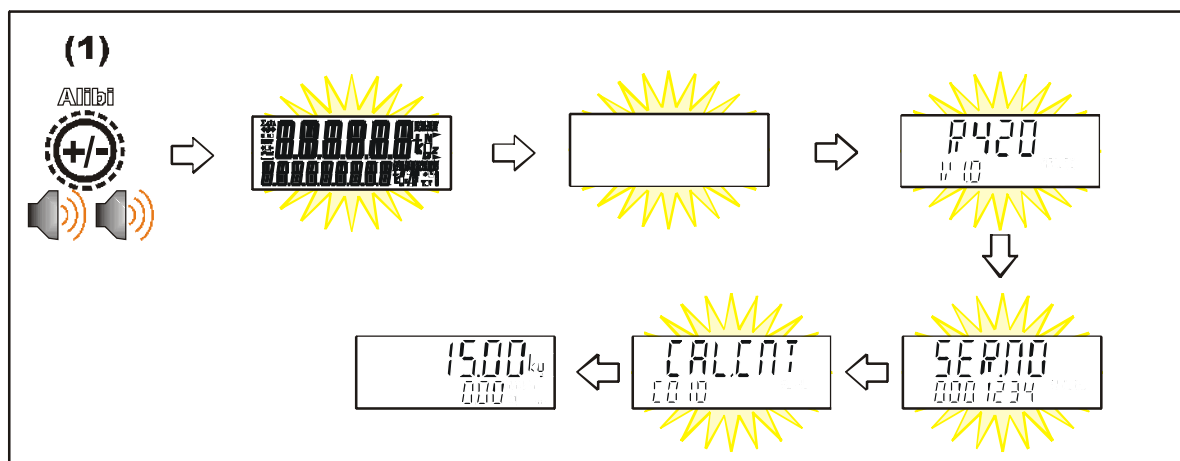

#### ◆ Viewing DSD records in Alibi mode

From Alibi mode you can view DSD records (when a DSD is fitted) by pressing the up arrow key to view the latest record, pressing the down arrow key to view the oldest record or by entering a number then pressing the OK key to view that specific record. Once viewing records you can use the +/- key to display the different information stored in the record, use the up arrow key to move onto the next record or use the down arrow key to move onto the previous record. Once you are finished viewing records you can return to Alibi mode by pressing the C key.

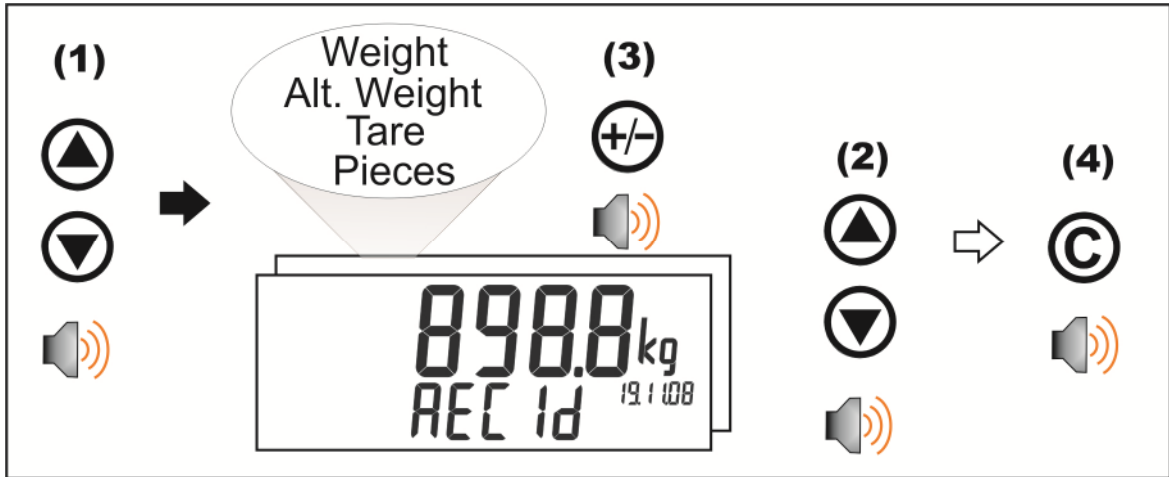

**5.2.15. Acc**

A long press of the 0 key (Acc) is used to view information about the attached accessory modules.

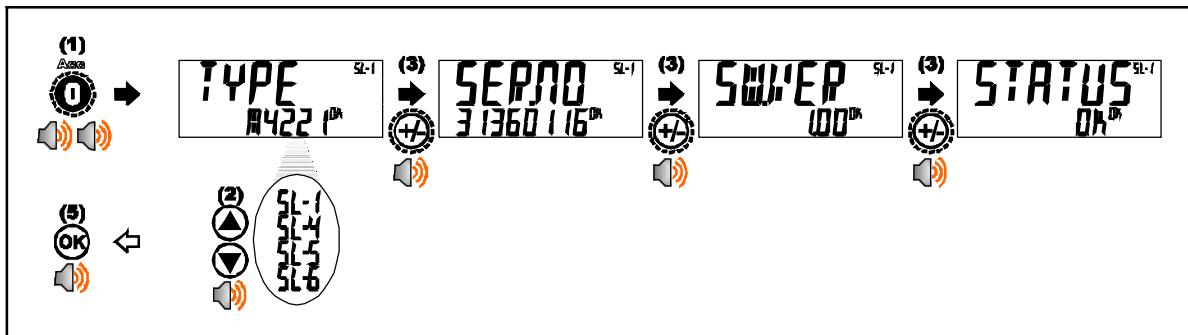

When a M4221 Ethernet module is attached, the current IP (Internet Protocol) settings can be viewed from the Acc menu. The "." key allows the second half of longer IP addresses to be displayed. In this example the DNS 2 IP address is 192.168.100.10.

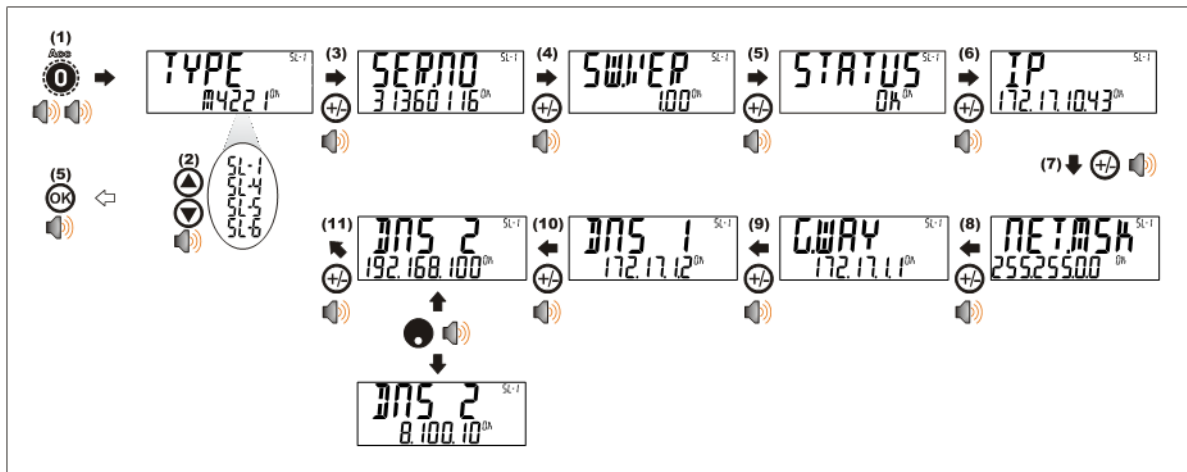

**5.2.16. Stability Considerations**

Some functions (e.g. Tare and Zero) require a stable weight. These functions will wait for up to 10 seconds for stable weight. If a stable weight is not available 'MOTION ERROR' is displayed and the function is cancelled.

## 6. Configuration

### 6.1. General Setup Information

Configuration and calibration can be performed entirely from the front panel, using the digital setup facility. When **Full Setup** is used, all menu items are accessible and care must be taken to ensure no accidental changes are made to calibration and trade settings. In addition, there is also **Safe Setup** that provides restricted access. This setup method ensures that only settings that are not calibration or trade sensitive can be changed.

Full and Safe Setup can be passcode protected to prevent unauthorised or accidental tampering.

### 6.2. Correct Loadcell Selection

It is important to ensure the signal strength from the connected loadcells is sufficiently high to match the capability of the instrument, especially when configuring a trade certified site.

The trade approved capability of the instrument is quoted as a maximum number of divisions with a minimum signal strength per division in micro-volts.

To illustrate the process consider the following example:

#### Example

Four 2,500kg 2.0mV/V load cells are used in an application requiring a 5,000kg full scale, with weight displayed in 5kg increments.

Calculating the total number of divisions:	Total Number of Divisions = $\frac{\text{Fullscale}}{\text{Count-by}} = \frac{5000\text{kg}}{5\text{kg}} = 1000\text{divisions}$
Calculating the full scale load cell signal:	Fullscale signal = $\frac{\text{Fullscale}}{\text{Load Cell Capacity}} \times \text{Loadcell signal (at capacity)}$ $= \frac{5000\text{kg}}{10000\text{kg}} \times 2.0\text{mV/V} = 1.0\text{mV/V}$
Calculating the absolute signal voltage:	Absolute Signal Voltage = Excitation Voltage x Fullscale Signal $= 7.4\text{V} \times 1.0\text{mV/V} = 7.4 \text{ mV}$
Calculating the signal resolution:	Signal Resolution = $\frac{\text{Absolute Signal Voltage}}{\text{Number of graduations}} = \frac{7.4\text{mV}}{1000 \text{ divisions}}$ $= 0.0074\text{mV/division} = 7.4\mu\text{V/division}$

### 6.3. Filtering Techniques

There is a trade off between noise filtering and the step-response time of the system. The step-response is defined as the time between placing a weight on the scale and the correct stable weight reading being displayed. This does not affect the number of readings per second that are taken. It simply defines the amount of time that is required to determine a final weight reading.

The **FILTER** setting in the instrument setup shows the amount of time over which the averaging is taken. Increasing the averaging time will result in a more stable reading but will extend the time it takes the instrument to settle to a final reading.

## 6.4. Industrial vs Trade Modes

The instrument may be operated in Industrial or Trade modes. These modes restrict certain aspects of the operation of the instrument to ensure compliance with trade certified standards.

The following table lists the operation differences for each of these modes.

Element	Industrial	Trade
<b>Underload</b>	-105% of Fullscale	-1% or -2% of Fullscale depending on zero range setting
<b>Overload</b>	105% of Fullscale	Fullscale + 9 divisions
<b>Tare</b>	No restrictions	Tare values must be > 0
<b>Test Modes</b>	Unlimited time allowed	Limited to five seconds

**Table 3: Industrial vs trade modes**

## 6.5. Calibration Counter

Within Setup there are a number of critical steps that can affect the calibration and/or legal for trade performance of the instrument. If any of these steps are altered, the trade certification of the scale could be voided.

The instrument provides built-in calibration counter(s) to monitor the number of times the critical steps are altered. The value of a counter is stored within the instrument and can only be reset at the factory. Each time a critical step is altered, the counter will increase by one. Whenever the instrument is powered up, or setup mode is entered/exited, the current value in the counter is displayed briefly (eg. C00010).

The value of the counter is written on the tamperproof trade label on the front of the indicator for trade-certified applications and functions as an electronic seal. If any legal for trade settings are changed on the instrument, the current value of the calibration counter will be different from the recorded value and the seal is broken. In this manual, items marked with Å indicate that the setting is legal for trade critical settings.

## 6.6. Passcodes

The instrument has three levels of passcode to provide security for instrument functions, calibration and general configuration.

- Full Setup Passcode
- Safe Setup Passcode
- Operator Passcode

The Full Setup passcode can also be used to access Safe Setup and Operator functions.

Instrument settings that are accessed by the communications are protected by the same passcodes.

### 6.6.1. Full Setup Passcode

Setting a passcode for Full Setup restricts access to Full Setup.

### 6.6.2. Safe Setup Passcode

Setting a passcode for Safe Setup restricts access to Safe Setup functions. In addition, front panel functions can be configured to prompt for a Safe Setup passcode before operating. Refer to 7.1.5 KEY.LOC (Key Function Access Control) on page 43 for more information.

### 6.6.3. Operator Passcode

The operator passcode is used to protect access to instrument functions available from the front panel keypad. Refer to 7.1.5 KEY.LOC (Key Function Access Control) on page 43 for more information on how to add security to operator functions.

The operator generally needs to enter the Operator Passcode only once to gain access to multiple functions. To lock the instrument again press the '.' key for two seconds (LOCK function).

### 6.6.4. Setup Lock-Out

If an attempt is made to enter Full or Safe Setup using an incorrect passcode, the instrument will respond with the message **ENTRY DENIED** and then the user will be returned to normal operating mode.

No more than three failed attempts can be made to access Full/Safe Setup before the instrument blocks access completely. The instrument must be turned off and on again before further attempts can be made.

## 7. Setup Menus

### 7.1. GEN.OPT (General options)

#### 7.1.1. LANG (Operator language)

Path	Description
GEN.OPT L LANG	Sets the operator language.
<b>LANG Values</b> <OPT>	<b>NB:</b> Setup menus are fixed in English.
<ul style="list-style-type: none"> <li>• English (Default)</li> <li>• German</li> <li>• Dutch</li> <li>• French</li> <li>• Polish</li> <li>• Italian</li> <li>• Spanish</li> <li>• Czech</li> </ul>	

#### 7.1.2. P.T.SCP (Preset Tare Scope)

Path	Description
GEN.OPT L P.T.SCP	Sets if the preset tare value is stored per product or globally
<b>P.T.SCP Values</b> <OPT>	
<ul style="list-style-type: none"> <li>• PROD (Default)</li> <li>• GLOBAL</li> </ul>	

#### 7.1.3. DATE.F (Date format)

Path	Description
GEN.OPT L DATE.F	Sets the date format
<b>DATE.F Values</b> <OPT>	
<ul style="list-style-type: none"> <li>• DD.MM.YY (Default)</li> <li>• DD.MM.YYYY</li> <li>• MM.DD.YY</li> <li>• MM.DD.YYYY</li> <li>• YY.MM.DD</li> <li>• YYYY.MM.DD</li> </ul>	

## 7.1.4. PCODE (Security passcodes)

Path	Description
GEN.OPT L PCODE L SAFE.PC L FULL.PC (*) L OP.PC  (*) Available in FULL SETUP only	Sets the instrument passcodes. The 3 levels of passcode are: <ul style="list-style-type: none"> <li>• Full passcode (FULL.PC): Controls access to full setup menus. All settings (including trade critical settings) can be altered from full setup. The full passcode will also give access to safe or operator functions.</li> <li>• Safe passcode (SAFE.PC): Controls access to safe setup menus. No trade critical settings can be altered from safe setup. The safe passcode will also give access to operator functions.</li> <li>• Operator passcode (OP.PC): Controls access to various operator functions.</li> </ul>
PCODE Values <NUM>	
0 .. 999999 Default: 0  <b>NB:</b> A passcode value of 0 deactivates the passcode.	

## 7.1.5. KEY.LOC (Key Function Access Control)

Path	Description
GEN.OPT L KEY.LOC L P(*) L ZERO L TARE L GR_NT L F1 L F2 L F3 L CLOCK L VIEW L REPORT L TOTAL L ID L TARGET L ACC L PR.MOD L PR.SEL L NUM.PAD L ALIBI	Access to each of the operator functions can be configured separately.  The options are: AVAIL: function always available OPER.PC: requires a valid Operator Passcode SAFE.PC: requires a valid Safe Passcode LOCKED: function never available  Functions protected with a 'Safe' passcode prompt for the passcode every time.  Entering the Operator Passcode unlocks all operator protected functions so the operator is not continually prompted for the passcode. In order to lock the instrument again press the '.' key for two seconds (function 'Lock').
KEY.LOC Values <OPT>	
<ul style="list-style-type: none"> <li>• AVAIL (Default)</li> <li>• OPER.PC</li> <li>• SAFE.PC</li> <li>• LOCKED</li> </ul> (*) AVAIL & LOCKED only are available for POWER.	

## 7.1.6. DISP (Display options)

Path	Description
GEN.OPT L DISP L <b>B.LIGHT</b> L <b>FREQ</b> L <b>AUX.DSP</b> L <b>VIEW</b>	These settings control the operation of the display. <b>B.LIGHT</b> (Backlight operation) can be set on or off. <b>FREQ</b> (Display update frequency) sets how often the display is updated <b>AUX.DSP</b> (Auxiliary Display) can be set to OFF, TIME to show the current instrument time or NUM.ITEMS to show the number of items added to totals.
<b>B.LIGHT Values</b> <OPT>	
ON <sup>(Default)</sup> , OFF	
<b>FREQ Values</b> <OPT>	
10Hz <sup>(Default)</sup> , 5Hz, 3.3Hz, 2Hz, 1Hz	
<b>AUX.DSP Values</b> <OPT>	
OFF <sup>(Default)</sup> , TIME, NUM.ITEMS	
<b>VIEW Values</b> <OPT>	
PRODUCT <sup>(Default)</sup> , TOP, DUAL	<b>VIEW</b> (Display Layout) selects the default VIEW when the instrument powers up. The operator can select alternative views by pressing the '2' key for 2 seconds (function 'View'). Options: PRODUCT: display product information TOP: only the primary display is shown.  The secondary display is used to show operator prompts received from the comms. DUAL: Primary and Secondary displays are used for scale information. (E.g. Net + Tare weight or Weight + Pieces).

## 7.1.7. ID.NAME (User Defined Strings)

Path	Description
GEN.OPT L ID.NAME L <b>NAME.1</b> L <b>NAME.2</b> L <b>NAME.3</b> L <b>NAME.4</b> L <b>NAME.5</b>	There are five User Strings available to the operator when the '5' key is pressed for 2 seconds (function 'ID'). NAME.1, NAME.2, NAME.3, NAME.4 and NAME.5 specify the actual prompts displayed for the operator. The values that the operator enters are used for printing and other application functions.
<b>Values</b> <STR>	
<i>Maximum 6 characters.</i>	(E.g. to allow the operator to enter a customer ID, NAME.1 could be set to 'CUST'.)  To remove a User String from the operator menu give it an empty name.

## 7.1.8. POWER (Power options)

Path	Description
GEN.OPT L POWER L AUT.OFF L START	<b>AUT.OFF</b> (Auto-off delay)  Sets the automatic power off setting. The instrument will switch off after set minutes of inactivity. NEVER disables the auto power off feature.
<b>AUT.OFF Values</b> <OPT>	
<ul style="list-style-type: none"> <li>• NEVER (Default)</li> <li>• 1 min</li> <li>• 5 min</li> <li>• 10 min</li> <li>• 60 min</li> </ul>	<b>START</b> (Pause at Start-up)  If ON the START function forces the instrument to pause on power up and prompt the operator to continue. This ensures that restarting the instrument does not go unnoticed.
<b>START Values</b> <OPT>	
OFF (Default), ON	

## 7.1.9. STR.EDT (String Edit Mode)

Path	Description
GEN.OPT L STR.EDT	Sets the mode that the string editor will start in.
<b>STR.EDT Values</b> <OPT>	
<ul style="list-style-type: none"> <li>• STRING (Default)</li> <li>• NUM</li> <li>• AUTO</li> </ul>	

## 7.1.10. USR.DEF (Set all non-calibration settings to defaults)

Path	Description
GEN.OPT L USER.DEF	Sets all general instrument settings to defaults.  This will not affect settings in the SCALE menu which includes all calibration and configuration settings.
<b>Values</b>	
DEFAULT? <OK> CONFIRM? <OK>	

## 7.2. H.WARE (Hardware Configuration & Test)

### 7.2.1. ALLOC (Allocation Report)

Path	Description
H.WARE L ALLOC	<p>Check hardware allocation.</p> <p>Displays the function of each item of hardware. Items of hardware include serial ports, function keys, inputs and outputs.</p> <p>Use the UP and DOWN arrows to step through the hardware.</p> <p>Use the +/- key to step through the available information for each item of hardware.</p> <p><b>Errors:</b> If a single item of hardware has been assigned to 2 or more functions, an error message is shown. "CHECK" is used if it is possible that the setup is OK. "CLASH" is shown if it is likely a setup error.</p>

### 7.2.2. LC.HW

Path	Description
H.WARE L LC.HW L MVV L OL.CNT L OL.CLR	<p><b>MVV</b></p> <p>View Loadcell mV/V reading.</p> <p><b>OL.CNT</b> (Overload count)</p> <p>Shows the number of times the instrument has been overloaded or underloaded by at least 50% of fullscale.</p> <p><b>OL.CLR</b> (Overload clear)</p> <p>Clear the overload counter.</p>

## 7.2.3. SER1.HW, SER2.HW

Path	Description
H.WARE	<b>BAUD</b> (Baud Rate)
L SER1.HW	Sets the baud rate for the port.
L BAUD	
L PARITY	<b>PARITY</b>
L DATA	Sets the parity for the port.
L STOP	
L DTR	<b>DATA</b> (Data bits)
L TERM	Sets the number of data bits for the port.
L SER2.HW	<b>STOP</b> (Stop bits)
L BAUD	Sets the number of stop bits for the port.
L PARITY	
L DATA	<b>DTR</b> (DTR usage)
L STOP	Use the DTR line with RS232 printing.
L DTR	<b>TERM</b> (Termination Resistors)
L TERM	Use termination resistors with RS485.
L RING	<b>RING</b> (Ring network)
	Enable ring network. Only available on SER2 and requires M42xx software version 1.01+.
<b>BAUD Values</b> <OPT>	
_1200_ , _2400_ , _4800_ , _9600_ (Default) , _19200_ , _57600_	
<b>PARITY Values</b> <OPT>	
NONE (Default) , EVEN, ODD	
<b>DATA Values</b> <OPT>	
_8_ (Default) , _7_	
<b>STOP Values</b> <OPT>	
_1_ (Default) , _2_	
<b>DTR Values</b> <OPT>	
OFF (Default) , ON	
<b>TERM Values</b> <OPT>	
OFF (Default) , ON	
<b>RING Values</b> <OPT>	
OFF (Default) , ON	

## 7.2.4. ETH.HW

Path	Description
H.WARE L ETH.HW L DHCP L IP L NET.MSK L G.WAY L DNS.1 L DNS.2	<p><b>DHCP</b> (Dynamic Host Configuration Protocol)</p> <p>Enables or disables the use of DHCP to configure the IP settings of the M4221 Ethernet module. To use this option requires a DHCP server on the network.</p> <p><b>IP</b> (Internet Protocol Address)</p> <p>Sets the IP address for the M4221 Ethernet module.</p> <p><b>NET.MSK</b> (Network Mask)</p> <p>Sets the network mask the M4221. This defines the proportion of the IP address bits that reside on the M4221's subnet.</p> <p><b>G.WAY</b> (Default Gateway)</p> <p>Sets the default gateway for the M4221. This is the server through which traffic destined for hosts beyond the M4221's subnet is routed.</p> <p><b>DNS.1</b> (Primary Domain Name Server)</p> <p>Sets the primary domain name server for the M4221. If not required use 0.0.0.0.</p> <p><b>DNS.2</b> (Secondary Domain Name Server)</p> <p>Sets the secondary domain name server for the M4221. If not required use 0.0.0.0.</p>
<b>DHCP Values</b> <OPT>	
ON (Default), OFF	
Note: IP, NET.MSK, G.WAY, DNS.1, DNS.2 settings are not available when DHCP is ON.	

## 7.2.5. ETH.DEF (Set the M4221 Ethernet module to defaults)

Path	Description
H.WARE L ETH.HW L ETH.DEF	<p>Sets all settings stored within the M4221 Ethernet module to defaults.</p> <p>This will not affect any instrument settings.</p>
<b>Values</b>	
DEFAULT? <OK> CONFIRM? <OK>	

## 7.2.6. IO.HW

Path	Description
H.WARE L IO.HW L FRC.OUT L TST.IN L DB.1.8 L DBNC.1 : L DBNC.8 L DB.9.16 L DBNC.9 : L DBNC.16 L DB.17.24 L DBNC.17 : L DBNC.24 L DB.25.32 L DBNC.25 : L DBNC.32	<p><b>FRC.OUT</b> (Force Outputs)</p> <p>Use this when testing and fault finding to force the IO on and off. Use the UP and DOWN keys to select the output. Use the +/- key to switch the output on and off.</p> <p><b>TST.IN</b> (Test Inputs)</p> <p>Use this when testing and fault finding to check the status of IO when used as inputs. Inputs are listed for each module in order of lowest to highest IO number. '1' means the input is active, '0' means the input is inactive. Use the UP and DOWN keys to select the module to view.</p> <p><b>DBNC</b> (Debounce)</p> <p>This sets the amount of debouncing for inputs. It is set in milliseconds [ms].</p>
<b>DBNC Values</b> <NUM>	
1..250 ms Default: 50 ms	

## 7.2.7. ANL.HW

Path	Description
H.WARE L ANL.HW L TYPE L CLIP L FRC.OUT L ANL.CAL L ADJ.LO L ADJ.HI	<p><b>TYPE</b> (Analog Output Type)</p> <p>Sets the analog output to current (4-20mA) or voltage (0-10V) mode.</p> <p><b>CLIP</b> (Analog Output Clip Enable)</p> <p>When clipping is on, the output is restricted to 4-20mA or 0-10V. When clipping is off, the output can go at least 3mA or 0.5V beyond these limits.</p>
<b>TYPE Values</b> <OPT>	<b>FRC.OUT</b> (Force Analog Output)
Current <sup>(Default)</sup> , Volt	Sets the number of data bits for the port.
<b>CLIP Values</b> <OPT>	<b>ADJ.LO</b> (Calibrate Analog Output)
NO <sup>(Default)</sup> , YES	Calibrate 4mA or 0V analog output. Use the UP and DOWN keys to adjust the calibration.
	<b>ADJ.HI</b> (Calibrate Analog Output)
	Adjust 20mA or 10V analog output. Use the UP and DOWN keys to adjust the calibration.

## 7.2.8. DSD.HW

Path	Description
H.WARE L DSD.HW L AUTO.C L DSD.STR	<b>AUTO.C</b> (Auto Clear)  Sets whether the DSD will automatically write over the oldest records when it becomes full.
<b>AUTO.C Values</b> <OPT>	<b>DSD.STR</b> (DSD String)  Custom string to be stored along with the traceable data when the DSD is written. This accepts all print tokens.
OFF, ON (Default)	
<b>DSD.STR Values</b> <STR>	
<i>Maximum 20 characters.</i>	

## 7.2.9. TILT.HW (K491 Only)

Path	Description
H.WARE L TILT.HW L ANGLE L FACTOR L ZERO L F.ZERO	<b>ANGLE</b>  Displays current X and Y angles. Used to test the operation of the tilt sensor. Use the UP and DOWN keys to switch between view options.  <b>FACTOR</b>  Displays the current tilt compensation factor. A factor of 1.000 equates to no compensation.  <b>ZERO</b>  Performs a user zero on the tilt sensor. This does not normally need to be used as the zero calibration procedure automatically does this.  <b>F.ZERO</b>  Restores the factory zero on the tilt sensor. This should be performed when installing a sensor that has already been used.

## 7.3. SCALE (Loadcell options and calibration)

## 7.3.1. BUILD (Scale parameters)

Path	Description
SCALE L BUILD L TYPE <sup>(Å)</sup> L CABLE <sup>(Å)</sup> L DP <sup>(Å)</sup> L CAP1 <sup>(Å)</sup> L E1 <sup>(Å)</sup> L CAP2 <sup>(*Å)</sup> L E2 <sup>(*Å)</sup> L UNITS <sup>(Å)</sup> L HI.RES <sup>(Å)</sup> L MAX.XY <sup>(Å)</sup> L MAX.X <sup>(Å)</sup> L MAX.Y <sup>(Å)</sup>	Scale Base configuration settings: <b>TYPE:</b> Range type. Options are: <ul style="list-style-type: none"> <li>• SINGLE : Single range</li> <li>• DUAL.I: Dual interval</li> <li>• DUAL.R: Dual range</li> </ul> <b>CABLE:</b> 6-wire or 4-wire cable termination: <ul style="list-style-type: none"> <li>• 6-wire: SENSE lines are connected to the instrument.</li> <li>• 4-wire: Internal connection between Excitation and SENSE lines is active.</li> </ul> <b>DP:</b> Set the decimal point position. <b>CAP1:</b> Sets the fullscale capacity for the scale. If using multiple interval/range, this sets the fullscale capacity of the lowest range/interval. <b>E1:</b> Sets the count-by (or resolution) of the scale. If using multiple interval/range, this sets the count-by (or resolution) of the lowest range/interval. <b>CAP2:</b> If using multiple interval/range, this sets the fullscale capacity of the highest range/interval. <b>E2:</b> If using multiple interval/range, this sets the count-by (or resolution) of the highest range/interval. <b>UNITS:</b> Sets the weighing units. <b>NB:</b> For Options: <ul style="list-style-type: none"> <li>• None: Units are left blank.</li> <li>• ARROW.U: Use the top arrow. Units will be printed onto the instrument in the correct location.</li> </ul> <b>HI.RES:</b> Sets the scale to high resolution (x10) mode. <b>MAX.XY:</b> (K491 only) Sets the maximum permissible XY combined angle of the system. If the maximum tilt is exceeded in either axis, "TILT.HI" will be displayed. <b>MAX.X:</b> (K491 only) Sets the maximum permissible X angle of the system. If the maximum tilt is exceeded in either axis, "TILT.HI" will be displayed. <b>MAX.Y:</b> (K491 only) Sets the maximum permissible Y angle of the system. If the maximum tilt is exceeded in either axis, "TILT.HI" will be displayed. ⊗: This item is trade critical and will affect the calibration counter(s) if changed.
<b>TYPE Values</b> <sup>(Å)</sup> <OPT>	
SINGLE (Default) DUAL.I, DUAL.R	
<b>CABLE Values</b> <sup>(Å)</sup> <OPT>	
6 WIRE (Default), 4 WIRE	
<b>DP Values</b> <sup>(Å)</sup> <OPT>	
000000 (Default)   000.000 00000.0   00.0000 0000.00   0.00000	
<b>CAP1 &amp; CAP2 Values</b> <sup>(Å)</sup> <NUM>	
100 ..999999 Default: 3000 <b>NB:</b> Numbers above assume no decimal point.	
<b>E1 &amp; E2 Values</b> <sup>(Å)</sup> <OPT>	
1 (Default)   20 2   50 5   100 10	
<b>UNITS Values</b> <sup>(Å)</sup> <OPT>	
None   g kg (Default)   Oz lb   N t   ARROW U	
<b>HI.RES Values</b> <sup>(Å)</sup> <OPT>	
OFF (Default), ON	
<b>MAX.TLT Values</b> <sup>(Å)</sup> <NUM>	
0 .. 15 Default: 10	

## 7.3.2. OPTION (Scale options)

Path	Description
SCALE L OPTION L <b>USE</b> <sup>(A)</sup> L <b>FILTER</b> <sup>(A)</sup> L <b>MOTION</b> <sup>(A)</sup> L <b>Z.RANGE</b> <sup>(A)</sup> L <b>Z.TRACK</b> <sup>(A)</sup> L <b>Z.INIT</b> <sup>(A)</sup> L <b>Z.BAND</b> <sup>(A)</sup> L <b>EXT.EX</b> <sup>(A)</sup> L <b>R.ENTRY</b> L <b>TOT.OPT</b>	<b>USE</b> (Trade Use): This setting affects the operation of trade functions. Options are: <ul style="list-style-type: none"> <li>• INDUST: Industrial (no standard)</li> <li>• OIML: OIML trade mode</li> <li>• NTEP: NTEP trade mode</li> </ul> <b>FILTER</b> : Set the number of seconds of digital filtering. <b>MOTION</b> : Sets the motion detection sensitivity. This setting is given as $x_d - y_t$ where weight change of more than $x$ divisions in $y$ seconds will trigger motion. <b>Z.RANGE</b> (Range of Zero): Sets the range over which the indicator can zero the scale. Options are in % of fullscale. <b>Z.TRAC</b> (Zero Tracking): Sets the rate of automatic zero tracking. Slow is 2Hz, Fast is 10Hz. <b>Z.INIT</b> (Zero on Startup): Enables the zero-on-start-up feature. When enabled, a zero will be performed as part of the instrument start-up procedure if the scale is within the zero range. <b>Z.BAND</b> (Zero Deadband): Sets the weight range around zero which will be considered zero for application purposes. <b>EXT.EX</b> (External Excitation): If using an external supply for loadcell excitation this setting enables additional background calibration services. Under normal conditions this feature is not required. <b>R.ENTRY</b> (Rear Entry): Full access via the rear setup button only. This option is only available when the rear setup button has been used to access the menu system <b>TOT.OPT</b> (Totalising Option): Type of weight used with totalising. Gross or net weight should be used if gross or net weights only can be added into a single total.
<b>USE Values</b> <sup>(A)</sup> <OPT>	
INDUST <sup>(Default)</sup> , OIML, NTEP	
<b>FILTER Values</b> <sup>(A)</sup> <NUM>	
0.01s..30.00s <i>Default: 1.0s</i>	
<b>MOTION Values</b> <sup>(A)</sup> <OPT>	
OFF, 0.5d – 1.0t <sup>(Default)</sup> 1.0d – 1.0t 2.0d – 1.0t 5.0d – 1.0t 0.5d – 0.5t	1.0d – 0.5t 2.0d – 0.5t 5.0d – 0.5t 0.5d – 0.2t 1.0d – 0.2t 2.0d – 0.2t 5.0d – 0.2t
<b>Z.RANGE Values</b> <sup>(A)</sup> <OPT>	
-2 .. 2 <sup>(Default)</sup> , -1 .. 3, -10 .. 10, -20 .. 20	
<b>Z.TRACK Values</b> <sup>(A)</sup> <OPT>	
Off <sup>(Default)</sup> , Slow, Fast	
<b>Z.INIT Values</b> <sup>(A)</sup> <OPT>	
Off <sup>(Default)</sup> , On	
<b>Z.BAND Values</b> <sup>(A)</sup> <NUM>	
0 – fullscale <i>Default: 0</i>	
<b>EXT.EX Values</b> <sup>(A)</sup> <OPT>	
Off <sup>(Default)</sup> , On	
<b>R.ENTRY Values</b> <OPT>	
Off <sup>(Default)</sup> , On	
<b>TOT.OPT Values</b> <OPT>	
Disp <sup>(Default)</sup> , Gross, Net	

⊗: This item is trade critical and will affect the calibration counter(s) if changed.

## 7.3.3. CAL (Scale calibration)

Path	Description
SCALE	Calibrate Scale
L CAL	<b>ZERO:</b> Perform a zero calibration.
LZERO <sup>(A)</sup>	<b>SPAN:</b> Perform a span calibration. A zero calibration should be done before doing a span calibration.
LSPAN <sup>(A)</sup>	<b>ED.LIN:</b> Add or Modify linearization points.
LED.LIN <sup>(A)</sup>	<b>CLR.LIN:</b> Clear unwanted linearization points.
LCLR.LIN <sup>(A)</sup>	<b>DIR.ZER</b> (Direct mV/V Zero Calibration): Enter signal strength (in mV/V) of zero calibration directly.
LDIR.ZERO <sup>(A)</sup>	<b>DIR.SPN</b> (direct mV/V span Calibration): Enter the signal strength (in mV/V) of fullscale directly. No test weights required.
LDIR.SPN <sup>(A)</sup>	<b>TILT.A – TILT.D</b> (Tilt Variables): K491 Only. These are the tilt compensation variables calculated by the tilt calibration process.
LTILT.A <sup>(A)</sup>	<b>LC.ZERO</b> (loadcell zero offset) K491 only. This sets the zero offset if your loadcell does not measure 0mV/V with no weight (no dead load) applied.
LTILT.B <sup>(A)</sup>	<b>DEF.CAL</b> (Default Calibration): Restore instrument to default factory calibration and reset all items in the SCALE menu to defaults.
LTILT.C <sup>(A)</sup>	
LTILT.D <sup>(A)</sup>	
LLC.ZERO <sup>(A)</sup>	
LDEF.CAL <sup>(A)</sup>	

⊗: This item is trade critical and will affect the calibration counter(s) if changed.

## 7.3.4. QA (QA alarm)

Path	Description
SCALE:	Configure the quality assurance feature.
L QA	If active the instrument displays a 'QA DUE' warning after the date limit has expired.
LQA.OPT <sup>(A)</sup>	<b>QA.OPT:</b> Turn QA feature on or off.
LQA.YEAR <sup>(A)</sup>	<b>QA.YEAR, QA.MONTH, QA.DAY:</b> Enter QA expiry date.
LQA.MONTH <sup>(A)</sup>	⊗: This item is trade critical and will affect the calibration counter(s) if changed.
LQA.DAY <sup>(A)</sup>	
<b>QA.OPT Values</b> <sup>(A)</sup> <OPT>	
Off (Default), On	
<b>QA.DATE Values</b> <sup>(A)</sup> <NUM>	
2000-01-01 To 2099-12-31	

## 7.4. FUNC (Special functions)

The instrument supports up to eight special functions. Enter the number of special functions to use and configure each one according to the function type required. Most functions need only to be associated with a key or input to function but some have additional configuration settings as detailed below.

### 7.4.1. NUM (Number of special functions)

Path	Description
FUNC L NUM	Sets the number of special functions.
<b>NUM Values &lt;OPT&gt;</b>	
-1- .. -8-	

### 7.4.2. SFn: TYPE (Function Types)

Path	Description
FUNC L SF <sub>n</sub> LTYPE	Sets the function type. Options are:
<b>TYPE Values &lt;OPT&gt;</b>	
<ul style="list-style-type: none"> <li>• NONE (Default)</li> <li>• PRINT</li> <li>• SINGLE</li> <li>• TEST</li> <li>• COUNT</li> <li>• PIECE</li> <li>• UNITS</li> <li>• HOLD</li> <li>• PK.HOLD</li> <li>• PRD.SEL</li> <li>• REM.KEY</li> <li>• BLANK</li> <li>• THUMB</li> <li>• REPORT</li> <li>• HI.RES</li> <li>• SC.EXIT</li> <li>• SEMI.P.T</li> <li>• A.TARE</li> </ul>	<ul style="list-style-type: none"> <li>• <b>PRINT</b>: Trigger a print out</li> <li>• <b>SINGLE</b>: Trigger a single serial weight transmission</li> <li>• <b>TEST</b>: Display test</li> <li>• <b>COUNT</b>: Piece Counting using a Sample</li> <li>• <b>PIECE</b>: Piece Counting using entered Piece Weight</li> <li>• <b>UNITS</b>: Unit switching, lb/kg or Custom</li> <li>• <b>HOLD</b>: Manual hold</li> <li>• <b>PK.HOLD</b>: Peak hold</li> <li>• <b>PRD.SEL</b>: Product Select</li> <li>• <b>REM.KEY</b>: Remote Key operation</li> <li>• <b>BLANK</b>: Blanking input</li> <li>• <b>THUMB</b>: Thumb-wheel Product Selection</li> <li>• <b>REPORT</b>: Print a report</li> <li>• <b>HI.RES</b>: High Resolution mode toggle</li> <li>• <b>SC.EXIT</b>: Trigger scale exit setpoint</li> <li>• <b>SEMI.P.T</b>: Semi-auto Preset Tare</li> <li>• <b>A.TARE</b>: Auto tare</li> </ul>

## 7.4.3. SFn: KEY (Function Key / Remote Input )

Path	Description
FUNC L SFn LKEY	Select front panel key or external input to trigger the special function. All functions that respond to input events have a KEY setting.
<b>KEY Values</b> <OPT>	Functions like THUMB (Thumbwheel) require multiple inputs to function and have an equivalent setting to specify these inputs.
None (Default), F1 .. F3 IO1 .. IO32	

## 7.4.4. SFn: PRINT (Printing Functions)

Path	Description						
FUNC L SFn L TYPE : PRINT L KEY L LONG.PR L PRT.OUT L TOTAL L CLR.ASK L AUTO L IL.TYPE L I.LOCK	Configuration of the PRINT Special Function.  <b>KEY:</b> Select PRINT key using front function key or external input.  <b>LONG.PR</b> (LONG PRESS): Selects if long press functionality should be enabled.  <b>PRT.OUT</b> (PRINT OUT): Selects the printout to print. Printouts are configured in the PRINT menu.  <b>TOTAL:</b> Sets whether the print key affects the product totals.						
<b>KEY Values</b> <OPT>	Options are:						
None <sup>(Default)</sup> , F1 .. F3, IO1 .. IO32	<ul style="list-style-type: none"> <li>• ADD: Add to totals</li> <li>• UNDO: Undo last add to totals</li> <li>• CLR.ALL: Clear all totals</li> <li>• CLR.SESS: Clear session total</li> </ul>						
<b>LONG.PR Values</b> <OPT>							
ENABLE <sup>(Default)</sup> , DISABLE							
<b>PRT.OUT Values</b> <OPT>	<b>CLR.ASK</b> (Prompt for Clear): Sets whether the operator is prompted to confirm the totals clear.						
None <sup>(Default)</sup> , PRINT.1 .. PRINT.2	<b>AUTO</b> (Automatic printing): Sets whether printing occurs automatically.						
<b>TOTAL Values</b> <OPT>	<b>IL.TYPE</b> (Interlock Type): Sets the type of printing interlock to be used. Options are:						
<table border="1"> <tr> <td>NONE <sup>(Default)</sup></td> <td>UNDO</td> </tr> <tr> <td>ADD</td> <td>CLR.ALL</td> </tr> <tr> <td></td> <td>CLR.SESS</td> </tr> </table>	NONE <sup>(Default)</sup>	UNDO	ADD	CLR.ALL		CLR.SESS	<ul style="list-style-type: none"> <li>• MOTION: Printing is enabled every time the scale becomes stable.</li> <li>• I.LOCK: Printing is enabled when the weight is stable after a weight movement larger than the interlock weight.</li> <li>• RET.Z: Printing is enabled after the scale has returned to zero and is stable at a reading other than zero.</li> </ul>
NONE <sup>(Default)</sup>	UNDO						
ADD	CLR.ALL						
	CLR.SESS						
<b>CLR.ASK Values</b> <OPT>	<b>I.LOCK</b> (Interlock): Sets the interlock weight.						
NO <sup>(Default)</sup> , YES							
<b>AUTO Values</b> <OPT>							
NO <sup>(Default)</sup> , YES							
<b>IL.TYPE Values</b> <OPT>							
<table border="1"> <tr> <td>NONE <sup>(Default)</sup></td> <td>MOTION</td> </tr> <tr> <td></td> <td>I.LOCK</td> </tr> <tr> <td></td> <td>RET.Z</td> </tr> </table>	NONE <sup>(Default)</sup>	MOTION		I.LOCK		RET.Z	
NONE <sup>(Default)</sup>	MOTION						
	I.LOCK						
	RET.Z						
<b>I.LOCK Values</b> <NUM>							
0 .. Fullscale							

## 7.4.5. SFn: SINGLE (Single Serial Output Functions)

Path	Description
FUNC L SFn L TYPE : SINGLE L KEY L AUT.OUT	Single serial outputs are similar to printing but do not support any interlocking or totalising functions.  <b>KEY:</b> Function key or external input to use.  <b>AUT.OUT:</b> Choose which Auto Output Serial service to trigger. The Auto Output TYPE should be set to SINGLE.
<b>KEY Values &lt;OPT&gt;</b>	
None <sup>(Default)</sup> , F1 .. F3, IO1 .. IO32	
<b>AUT.OUT Values &lt;OPT&gt;</b>	
AUTO.1 <sup>(Default)</sup> , AUTO.2	

## 7.4.6. SFn: BLANK (Blanking Functions)

Path	Description
FUNC L SFn L TYPE : BLANK L KEY L BLANK	Blanking functions enable the detection of external inputs to be used to block instrument operation by blanking the screen and blocking key functions.  Typical applications are for tilt sensing.  <b>KEY:</b> External input to use.
<b>KEY Values &lt;OPT&gt;</b>	<b>BLANK:</b> Set display blanking style. Options are:
None <sup>(Default)</sup> , F1 .. F3, IO1 .. IO32	<ul style="list-style-type: none"> <li>• DASH: Fill instrument display with '-' characters.</li> <li>• BLANK: completely blank instrument display.</li> </ul>
<b>BLANK Values &lt;OPT&gt;</b>	
DASH <sup>(Default)</sup> , BLANK	

## 7.4.7. SFn: COUNT, SFn: PIECE (Counting Functions)

Path	Description
FUNC L SFn L TYPE : COUNT PIECE L KEY L LONG.PR L SCOPE L EDT.WGT L MAX.ADJ L EDT.CNT	<p>Counting functions are performed either by the COUNT or PIECE special functions. The COUNT determines piece weight using a measure sample of a number of pieces while the PIECE function allows the operator to enter piece weight directly.</p> <p><b>KEY:</b> Select key or external input to use.</p> <p><b>LONG.PR</b> (LONG PRESS: Selects if long press functionality should be enabled.</p> <p><b>SCOPE:</b> The piece or sample weight can be set to be identical for all products (GLOBAL) or different for each product (PROD).</p> <p><b>EDT.WGT:</b> (COUNT only) Select if to prompt for the weight or not. Resample allows you to keep adding pieces to adjust the sample size.</p> <p><b>MAX.ADJ:</b> (COUNT only) This sets the maximum percentage change in calculated piece weight allowed for a resample.</p> <p><b>EDT.CNT:</b> (COUNT only) Select if to prompt for count or not. If set to off the count will be set to 100 automatically. This can be used to set 100%.</p>
<b>KEY Values</b> <OPT>	
None <sup>(Default)</sup> , F1 .. F3, IO1 .. IO32	
<b>LONG.PR Values</b> <OPT>	
ENABLE <sup>(Default)</sup> , DISABLE	
<b>SCOPE Values</b> <OPT>	
GLOBAL <sup>(Default)</sup> , PROD	
<b>EDT.WGT Values</b> <OPT>	
OFF, WEIGHT <sup>(Default)</sup> , RESAMPLE	
<b>MAX.ADJ Values</b> <NUM>	
0 .. 100, <i>Default: 1</i>	
<b>EDT.CNT Values</b> <OPT>	
OFF, ON <sup>(Default)</sup>	

## 7.4.8. SFn: UNITS (Unit Switching Functions)

Path	Description
FUNC L SFn L TYPE : UNITS L KEY L LONG.PR L MODE L UNIT (*) L U.STR (*) L SCOPE (*)	Unit Switching enables the display and printing of alternative units to those used for the primary calibration of the instrument.  <b>KEY:</b> Select key or external input to use.  <b>LONG.PR</b> (LONG PRESS: Selects if long press functionality should be enabled.  <b>MODE:</b> Sets the unit switching mode. Options are: <ul style="list-style-type: none"> <li>kg/lb (default): The instrument will convert kilograms to pounds or pounds to kilograms (depending on the primary unit).</li> <li>CUSTOM: The instrument will convert primary units to a custom unit defined by an entered conversion factor.</li> </ul>
<b>KEY Values</b> <OPT>	
None (Default), F1 .. F3, IO1 .. IO32	
<b>LONG.PR Values</b> <OPT>	
ENABLE (Default), DISABLE	
<b>MODE Values</b> <OPT>	
<ul style="list-style-type: none"> <li>kg/lb (Default)</li> <li>CUSTOM</li> </ul>	
<b>UNIT Values</b> <OPT>	
<ul style="list-style-type: none"> <li>NONE (Default)</li> <li>N</li> <li>ARROW U</li> <li>P</li> <li>L</li> <li>ARROW L</li> </ul>	<b>UNIT</b> (Alternative Unit Annunciator): Set the symbols to use for alternative units on the instrument display. Options are: <ul style="list-style-type: none"> <li>N: Useful for Newtons of Force.</li> <li>ARROW.U: Upper unit arrow</li> <li>P: useful for Pints.</li> <li>L: lower case 'l' for litres.</li> <li>ARROW.L: Lower unit arrow</li> </ul>
<b>U.STR Values</b> <STR>	
4 character string	
<b>SCOPE Values</b> <OPT>	
GLOBAL (Default), PROD	<b>U.STR</b> (Unit String): Four character alternative units string. Used in printing alternative units.  <b>SCOPE:</b> The conversion factor can be set to be identical for all products (GLOBAL) or different for each product (PROD).

## 7.4.9. SFn: HOLD

Path	Description
FUNC L SFn L TYPE : HOLD L KEY	The hold key/input implements a manual hold.  <b>KEY:</b> Select key or external input to use.
<b>KEY Values</b> <OPT>	
None (Default), F1 .. F3, IO1 .. IO32	

## 7.4.10. SFn: PK.HOLD (Peak Hold)

Path	Description
FUNC L SF <sub>n</sub> LTYPE : HOLD L KEY L LONG.PR	A peak hold key/input implements a peak hold where the largest absolute weight, either positive or negative is stored and displayed.  <b>KEY:</b> Select key or external input to use.  <b>LONG.PR</b> (LONG PRESS: Selects if long press functionality should be enabled.
<b>KEY Values</b> <OPT>	
None <sup>(Default)</sup> , F1 .. F3, IO1 .. IO32	
<b>LONG.PR Values</b> <OPT>	
ENABLE <sup>(Default)</sup> , DISABLE	

## 7.4.11. SFn: PRD.SEL (Product Select)

Path	Description
FUNC L SF <sub>n</sub> LTYPE : PRD.SEL L KEY L LONG.PR	The product select key/input will cycle through the available totals information for the current product and allows the current product to be selected by number rather than name.  <b>KEY:</b> Select key or external input to use.  <b>LONG.PR</b> (LONG PRESS: Selects if long press functionality should be enabled.
<b>KEY Values</b> <OPT>	
None <sup>(Default)</sup> , F1 .. F3, IO1 .. IO32	
<b>LONG.PR Values</b> <OPT>	
ENABLE <sup>(Default)</sup> , DISABLE	

## 7.4.12. SFn: THUMB (Thumbwheel Product Selection)

Path	Description
FUNC L SF <sub>n</sub> LTYPE : THUMB L IO.BAND	The Thumbwheel function supports the use of an external thumbwheel to select the current product using the product number.  A selection of '0' on the thumbwheel enables keyboard selection of the current product.  <b>IO.BAND:</b> Select which four remote inputs are used for the thumbwheel function.
<b>IO.BAND Values</b> <OPT>	
IO1-4 <sup>(Default)</sup> , IO5-8, IO9-12, IO13-16,  IO17-20, IO21-24, IO25-28, IO29-32	

## 7.4.13. SFn: REM.KEY (Remote Key Functions)

Path	Description
FUNC L SFn L TYPE : REM.KEY L KEY L FUNC	Remote key functions allow external inputs to be used to trigger instrument key functions.  The external 'keys' operate even if the instrument keys are locked and never require Operator or Setup passcodes to be entered.
<b>KEY Values</b> <OPT>	<b>KEY:</b> External input to use.
None <sup>(Default)</sup> , IO1 .. IO32	<b>FUNC:</b> Choose key function.
<b>FUNC Values</b> <OPT>	
NONE <sup>(Default)</sup> , ZERO, TARE, GR/NET, 0, 1, 2, 3, 4, 5, 6, 7, 8, 9, +/-, ., CANCEL, UP, DOWN, OK	

## 7.4.14. SFn: REPORT (Report Printing Functions)

Path	Description
FUNC L SFn L TYPE : REPORT L KEY L PRT.OUT L CLR.TOT	Configuration of the PRINT Special Function.  <b>KEY:</b> Select PRINT key using front function key or external input.  <b>PRT.OUT (PRINT OUT):</b> Selects the printout to print. Printouts are configured in the PRINT menu.  <b>CLR.TOTAL:</b> Sets whether the print key affects the product totals.
<b>KEY Values</b> <OPT>	Options are:
None <sup>(Default)</sup> , F1 .. F3, IO1 .. IO32	<ul style="list-style-type: none"> <li>• NO: Add to totals</li> <li>• ASK: Undo last add to totals</li> <li>• CLEAR: Clear all totals</li> </ul>
<b>PRT.OUT Values</b> <OPT>	
None <sup>(Default)</sup> , PRINT.1 .. PRINT.2	
<b>CLR.TOTAL Values</b> <OPT>	
NO <sup>(Default)</sup> , ASK, CLEAR	

## 7.4.15. SFn: HI.RES (High Resolution)

Path	Description
FUNC L SF $n$ LTYPE : HI.RES L KEY	Key/input to toggle to high resolution mode. <b>KEY:</b> Select key or external input to use.
<b>KEY Values</b> <OPT>	
None <sup>(Default)</sup> , F1 .. F3, IO1 .. IO32	

## 7.4.16. SFn: SC.EXIT (Scale Exit)

Path	Description
FUNC L SF $n$ LTYPE : SC.EXIT L KEY	Key/input to trigger scale exit (SC.EXIT) setpoint. <b>KEY:</b> Select key or external input to use.
<b>KEY Values</b> <OPT>	
None <sup>(Default)</sup> , F1 .. F3, IO1 .. IO32	

## 7.4.17. SFn: SEMI.P.T (Semi-auto Preset Tare)

Path	Description
FUNC L SF $n$ LTYPE : SEMI.P.T L KEY	Key/input to set the preset tare to the current gross weight. <b>KEY:</b> Select key or external input to use.
<b>KEY Values</b> <OPT>	
None <sup>(Default)</sup> , F1 .. F3, IO1 .. IO32	

## 7.4.18. SFn: A.TARE (Auto Tare)

Path	Description
FUNC L SFn LTYPE : A.TARE L KEY L THRESH L ZER.DLY	Key/input to set the preset tare to the current gross weight.  <b>KEY:</b> Select key or external input to use.  <b>THRESH:</b> Weight threshold to reach before automatically taring.  <b>ZER.DLY:</b> Delay before returning to gross weight when inside the zero band.
<b>KEY Values</b> <OPT>	
None <sup>(Default)</sup> , F1 .. F3, IO1 .. IO32	
<b>TRESH Values</b> <NUM>	
0 <sup>(Default)</sup> .. Fullscale	
<b>ZER.DLY Values</b> <NUM>	
0.0 .. 10.0 s <i>Default: 5.0</i>	

## 7.5. SER.NET (Network communications K401, K402 and K491)

Path	Description
L SER.NET L ADDR L NUM L NET.n L TYPE L SERIAL L RESP L SOURCE	Configure the serial networking support. <b>ADDR</b> (Address): Address of instrument (1..31). <b>NUM</b> : sets the number of networks <b>TYPE</b> : Type of Network Protocol: <ul style="list-style-type: none"> <li>• NONE: Disable networking</li> <li>• Protocol B: See Network Communications page 81.</li> <li>• Simple commands: See Network Communications page 81.</li> <li>• Barcode: See Network Communications page 81.</li> </ul> <b>SERIAL</b> : Serial Port to use. <b>RESP</b> : Respond with OK to simple commands. <b>SOURCE</b> : Barcode protocol source, settable to product name (NAME), product barcode (B.CODE) or product ID (ID).
<b>ADDR Values</b> <NUM>	
1 .. 31	
<b>NUM Values</b> <OPT>	
-1- (Default) .. -2-	
<b>TYPE Values</b> <OPT>	
NONE (Default), PROTOCOL.B, SIMPLE, BARCODE	
<b>SERIAL Values</b> <OPT>	
SER1A <sup>(Default)</sup> , SER2A, SER3A	
<b>RESP Values</b> <OPT>	
NONE <sup>(Default)</sup> , OK	
<b>SOURCE Values</b> <OPT>	
NAME <sup>(Default)</sup> , B.CODE, ID	

## 7.6. SER.NET (Network communications K403)

Path	Description
L SER.NET L ADDR L NUM L NET.n L TYPE L SERIAL L INP.1 L CMD.1	Configure the serial networking support. <b>ADDR</b> (Address): Address of instrument (1..31). <b>NUM</b> : sets the number of networks <b>TYPE</b> : Type of Network Protocol: <ul style="list-style-type: none"> <li>• NONE: Disable networking</li> <li>• Protocol B: See Network Communications page 81.</li> <li>• USER.DEF: User defined communications</li> </ul> <b>SERIAL</b> : Serial Port to use. <b>INP.1</b> : User defined input command <b>CMD.1</b> : Protocol B translation of INP.1
<b>ADDR Values</b> <NUM>	
1 .. 31	
<b>NUM Values</b> <OPT>	
-1- (Default) .. -2-	
<b>TYPE Values</b> <OPT>	
NONE (Default), PROTOCOL.B, USER.DEF	
<b>SERIAL Values</b> <OPT>	
SER1A <sup>(Default)</sup> , SER2A, SER3A	
<b>INP.1 Values</b> <STR>	
<i>Maximum 10 characters</i>	
<b>CMD.1 Values</b> <STR>	
<i>Token String</i>	

## 7.7. SER.AUT (Automatic transmit)

## 7.7.1. NUM (Number of Automatic Transmissions)

Path	Description
SER.AUT L NUM	Sets the number of special automatic outputs
Values <OPT>	
-1- (Default) .. -2-	

## 7.7.2. AUTO.n (Automatic Output Configuration)

Path	Description
SER.AUT L AUTO.n L TYPE L SERIAL L FORMAT L SOURCE L EV.AUTO(*)	These settings are the same for AUTO.1 and AUTO.2
TYPE Values <OPT>	<b>TYPE:</b> Sets the transmission rate. Options are:
NONE (Default) SINGLE AUTO.LO	<ul style="list-style-type: none"> <li>• SINGLE: A SINGLE function key is used to trigger a single transmission. Rate is determined by external input.</li> <li>• AUTO.LO: Transmit at 10Hz</li> <li>• AUTO.HI: Transmit at 25Hz frequency</li> <li>• AUT.TRC: Sends a message for every traceable weight (Print event).</li> </ul>
SERIAL Values <OPT>	<b>SERIAL:</b> Select Serial port to use.
SER1A (Default), SER1B, SER2A, SER2B, SER3A, SER3B	<b>FORMAT:</b> Set data format. See page 88.
FORMAT Values <OPT>	<ul style="list-style-type: none"> <li>• FMT.TRC to provide a tally roll printer log.</li> </ul>
FMT.A (Default) FMT.B FMT.C FMT.D	<b>SOURCE:</b> Sets the weight data to send:
FMT.E FMT.REG FMT.TRC CUSTOM	<ul style="list-style-type: none"> <li>• GROSS: Gross weight</li> <li>• Net: Net weight</li> <li>• Gr.or.Nt: Gross or net weight</li> </ul>
SOURCE Values <OPT>	<b>EV.AUTO:</b> Token string to define data format for CUSTOM transmissions.
GROSS (Default), NET GR.or.NT	
EV.AUTO Values <STR>	
Token String (*) Only used with CUSTOM format.	

## 7.8. PRINT (Printouts)

### 7.8.1. NUM (Number of printouts)

Path	Description
PRINT L NUM	Sets the number of printouts.
<b>Values &lt;OPT&gt;</b>	
_1_ (Default) .. _2_	

### 7.8.2. HEADER (Print header)

Path	Description
PRINT L HEADER	Sets the print docket header.
<b>Values &lt;STR&gt;</b>	
String	

### 7.8.3. FOOTER (Print footer)

Path	Description
PRINT L FOOTER	Sets the print docket footer.
<b>Values &lt;STR&gt;</b>	
String	

### 7.8.4. PAGE (Print page options)

Path	Description
PRINT L PAGE L WIDTH L HEIGHT L PG.END	Page settings configure the height and width of the paper and what to do at the bottom of a page. <b>WIDTH:</b> Sets the page width. A setting of zero disables page width checking. <b>HEIGHT:</b> Sets the page height. A setting of zero disables page height checking. <b>PG.END (Page End String):</b> Sets the string to print at page end. This option allows a cut character, form feed, etc, to be added every page.
<b>WIDTH Values &lt;NUM&gt;</b>	
0 .. 250 Default: 0	
<b>HEIGHT Values &lt;NUM&gt;</b>	
0 .. 250 Default: 0	
<b>PG.END Values &lt;STR&gt;</b>	
Token String	

## 7.8.5. SPACE (Print blank space options)

Path	Description
PRINT L SPACE L TOP L LEFT L BOTTOM	Space controls the amount of white space to leave around the printout. <b>TOP:</b> Sets the number of blank lines to add at the top of each page. <b>LEFT:</b> Sets the number of spaces to add at the beginning of each line. <b>BOTTOM:</b> Sets the number of blank lines to add to the bottom of each page.
<b>Values</b> <NUM>	
0 .. 10 <i>Default: 0</i>	

## 7.8.6. PRINT.n ... (Printout options)

Path	Description
PRINT L PRINT.n L TYPE L FORMAT L SERIAL L NAME L CUSTOM (*) L REC.PRN <i>or</i> L PRN.KEY L EV.D.NEW L EV.D.END L EV.P.NEW L EV.P.END <i>or</i> L REP.ST L REP.PR L REP.END	Each printout has its own format settings. <b>TYPE:</b> Sets the printout type. Options are: <ul style="list-style-type: none"> <li>• NONE (default)</li> <li>• RECORD</li> <li>• DOCKET</li> <li>• REPORT</li> </ul> <b>FORMAT:</b> Sets the printout format. <b>SERIAL:</b> Select Serial port to use. <b>NAME (Printout Name):</b> Report printouts are available by name to the operator. <b>CUSTOM:</b> For custom printing, each type of printout uses event strings as follows: <b>RECORD:</b> REC.PRN (Record Print): defines entire printout. <b>DOCKET:</b> PRN.KEY (Print Key) controls the format of each transaction on the docket. EV.D.NEW (Event Docket New) defines the start of the docket. EV.D.END (Event Docket End) defines the end of the docket. EV.P.NEW (Event Product New) defines what is printed when a new product is selected. EV.P.END (Event Product End) defines what is printed just before a new product is made active. <b>REPORT:</b> REP.ST (Report Start) defines start of report. REP.PR (Report Product) controls the information printed for each product. REP.END (Report End) defines the end of the report.
<b>TYPE Values</b> <OPT>	
NONE <sup>(Default)</sup> , RECORD, DOCKET, REPORT	
<b>FORMAT Values</b> <OPT>	
FMT.A <sup>(Default)</sup> , FMT.B, CUSTOM	
<b>SERIAL Values</b> <OPT>	
SER1A <sup>(Default)</sup> , SER2A, SER3A	
<b>NAME Values</b> <STR>	
6 character String	
<b>CUSTOM Values</b> <STR>	
(*) Active token strings depend on the TYPE setting	

## 7.9. SETP (Setpoints)

### 7.9.1. NUM (Number of setpoints)

Path	Description
SETP └ NUM	Sets the number of special setpoints
<b>Values &lt;OPT&gt;</b>	
└ 1 ... └ 8 (Default)	

### 7.9.2. SETP1 ... SETP8 (Setpoint options)

Path	Description
SETP └ SETP <sub>n</sub> └ TYPE └ OUTPUT └ LOGIC └ ALARM └ SOURCE (*) └ SCOPE (**) └ HYS (**) └ MASK (***) └ DLY.ON (***) └ HLD.OFF (***) └ RDY.TIM (****) └ REG (*****) └ NAME	Configure the operation of each setpoint.  <b>TYPE</b> determines the function of the setpoint. Options are:
<b>TYPE Values &lt;OPT&gt;</b>	
<ul style="list-style-type: none"> <li>• NONE (Default)</li> <li>• ON</li> <li>• OVER</li> <li>• UNDER</li> <li>• COZ</li> <li>• ZERO</li> <li>• NET</li> <li>• MOTION</li> <li>• ERROR</li> <li>• LGC.AND</li> <li>• LGC.OR</li> <li>• LGC.XOR</li> <li>• SC.REDY</li> <li>• SC.EXIT</li> <li>• BUZZER</li> </ul>	<ul style="list-style-type: none"> <li>• NONE : Always inactive</li> <li>• ON: Always active</li> <li>• OVER: active if weight over target</li> <li>• UNDER: active of weight under target</li> <li>• COZ: active if Centre of Zero</li> <li>• ZERO: active if weight is zero</li> <li>• NET: active if net weight selected</li> <li>• MOTION: active if weight unstable</li> <li>• ERROR: active if error conditions detected</li> <li>• LGC.AND: active if inputs match the bits set in the mask exactly</li> <li>• LGC.OR: active if any inputs match the bits set in the mask</li> <li>• LGC.XOR: active if only one input matches the bits set in the mask</li> <li>• SC.REDY: active when scale is stable and at centre of zero for more than the time set in RDY.TIM</li> <li>• SC.EXIT: active when outside of zero band and a print event has occurred, or can be triggered by SC.EXIT special function input.</li> <li>• BUZZER: active when the buzzer sounds.</li> </ul>
<b>OUTPUT Values &lt;OPT&gt;</b>	
NONE (Default), IO1 .. IO32	<b>OUTPUT</b> specifies which IO to use or the setpoint output.
<b>LOGIC Values &lt;OPT&gt;</b>	
HIGH (Default), LOW	<b>LOGIC:</b> Logic HIGH forces the output to follow the setpoint activity, the output will be on when the setpoint is active. Logic LOW forces the output to the reverse of the setpoint activity, the output will be off when the setpoint is active.
<b>ALARM Values &lt;OPT&gt;</b>	
NONE (Default) SINGLE	DOUBLE FLASH

<p><b>SOURCE Values</b> &lt;OPT&gt;</p> <ul style="list-style-type: none"> <li>• GROSS<sup>(*)</sup> (Default)</li> <li>• NET<sup>(*)</sup></li> <li>• GR.or.NT<sup>(*)</sup></li> <li>• ALT.GR<sup>(*)</sup></li> <li>• ALT.NET<sup>(*)</sup></li> <li>• ALT.G.or.N<sup>(*)</sup></li> <li>• PIECE<sup>(*)</sup></li> <li>• IO<sup>(***)</sup></li> <li>• STATUS<sup>(***)</sup></li> <li>• SETP<sup>(***)</sup></li> <li>• REG<sup>(*****)</sup></li> </ul> <p><sup>(*)</sup><b>NB:</b> Only for OVER, UNDER and ZERO setpoints.  <sup>(***)</sup><b>NB:</b> Only for LGC.AND, LGC.OR and LGC.XOR setpoints.  <sup>(*****)</sup><b>NB:</b> Only for OVER, UNDER, LGC.AND, LGC.OR and LGC.XOR setpoints.</p>	<p><b>ALARM:</b> Alarms are triggered when the setpoint is active. Options are:  NONE: no alarm  SINGLE: single BEEP  DOUBLE: double BEEP  FLASH: flash display</p> <p><b>SOURCE:</b> Select which weight values the setpoint checks against the target weight. Options are:  GROSS: Gross weight always  NET: Net weight always  GR.or.NT: Gross or Net depending on which one is displayed.  ALT.GR: Alternate Gross weight always  ALT.NET: Alternate Net weight always  ALT.G.or.N: Alternate Gross or Net depending on which one is displayed  PIECE: Gross or Net Piece count depending on which one is displayed  IO: perform logic setpoints on the IO status.  STATUS: perform logic setpoints on the current instrument status.  SETP: perform logic setpoints on the setpoint status.  REG: Register value.</p>
<p><b>SCOPE Values</b> &lt;OPT&gt;</p> <ul style="list-style-type: none"> <li>• GLOBAL<sup>(Default)</sup></li> <li>• PROD</li> </ul> <p><sup>(**)</sup><b>NB:</b> Only for OVER, and UNDER setpoints.</p>	<p><b>SCOPE:</b> The setpoint target can be set to be identical for all products (GLOBAL) or different for each product (PROD).</p>
<p><b>HYS Values</b> &lt;NUM&gt;</p> <p>0 to 999999  Default: 0</p> <p><sup>(**)</sup><b>NB:</b> Only for OVER, and UNDER setpoints.</p>	<p><b>HYS:</b> Hysteresis defines the amount of weight required for an active setpoint to become inactive again.</p> <p>A value of 0 still allows for 0.5 graduations of hysteresis.</p>
<p><b>MASK Values</b> &lt;NUM&gt;</p> <p>0 to 4294967295  Default 0</p> <p><sup>(***)</sup><b>NB:</b> Only for LGC.AND, LGC.OR and LGC.XOR setpoints</p>	<p><b>MASK:</b> a 32 bit number that is used by the logic setpoints to match the setpoint source.</p> <p><b>DLY.ON:</b> Delay for logic setpoints before setpoint becomes active.</p> <p><b>HLD.OFF:</b> Delay for logic setpoints before setpoint becomes inactive.</p>
<p><b>DLY.ON Values</b> &lt;NUM&gt;</p> <p>0.00 to 600.00s  Default 0s</p> <p><sup>(***)</sup><b>NB:</b> Only for LGC.AND, LGC.OR and LGC.XOR setpoints</p>	<p><b>RDY.TIM:</b> the time that the scale must be in the zero band and stable before the SC.REDY setpoint will become active</p>
<p><b>HLD.OFF Values</b> &lt;NUM&gt;</p> <p>0.00 to 600.00s</p>	<p><b>REG:</b> select which register to use as the source for the setpoint, must be a number or a weight. Decimal values for the registers should be used.</p> <p><b>NAME:</b> give the setpoint a name, this will be shown when editing targets.</p>

<p><i>Default 0s</i></p> <p>(***)<b>NB:</b> Only for LGC.AND, LGC.OR and LGC.XOR setpoints</p> <p><b>RDY.TIM Values</b> &lt;NUM&gt;</p> <p>0.000 to 60.000 s <i>Default: 0.000</i></p> <p>(****)<b>NB:</b> Only for SC.REDY setpoints.</p> <p><b>REG Values</b> &lt;NUM&gt;</p> <p>0 to 65535 <i>Default: 0</i></p> <p>(*****)<b>NB:</b> Only for OVER, UNDER, LGC.AND, LGC.OR and LGC.XOR setpoints.</p> <p><b>NAME Values</b> &lt;STR&gt;</p> <p>6 character String</p>	
---	--

#### 7.10. ANL.OUT (Analogue Output)

Path	Description
ANL.OUT L <b>ABS</b> L <b>SOURCE</b> L <b>RANGE</b> L <b>WGT.LO</b> L <b>WGT.HI</b>	Configures the operation of the analogue transmission.  <b>ABS</b> (Absolute Weight): Transmit negative weight values the same as positive weight values.  <b>SOURCE:</b> GROSS, NET, GR.or.NT  <b>RANGE:</b> Set the weight range. Options are: FULLSCALE: 0 to fullscale CUSTOM: Use WGT.LO and WGT.HI  <b>WGT.LO</b> (Weight Low): Weight corresponding to the lower analogue limit. (e.g. 0 volts or 4 mA)  <b>WGT.HI</b> (Weight High): Weight corresponding to the higher analogue limit. (e.g. 10Volts or 20 mA)
<b>ABS Values</b> <OPT>	
NO (Default), YES	
<b>SOURCE Values</b> <OPT>	
GROSS (Default), NET GR.or.NT	
<b>RANGE Values</b> <OPT>	
FULLSCALE (Default), CUSTOM	
<b>WGT Values</b> <NUM>	
-999999 .. 999999	

#### 7.11. End (Save and exit)

## 8. Calibration

The calibration of the indicator is fully digital. The calibration results are stored in permanent memory for use each time the instrument is powered up.

**Note: Some of the digital setup steps can affect calibration. The SCALE:BUILD and SCALE:OPTION settings MUST be configured before calibration is attempted.**

To perform a calibration, when in Full Setup select the **SCALE:CAL** menu.

The calibration programme will automatically prevent the instrument from being calibrated into an application outside of its specification. If an attempt is made to calibrate outside of the permitted range, an error message will display and the calibration will be abandoned. Refer to Calibration Errors page 79.

**Note: It should not be assumed that just because the instrument has successfully calibrated a scale, that the scale is correct for trade use. Always check the scale build against the approval specification.**

### 8.1. Performing a Digital Calibration with Test Weights

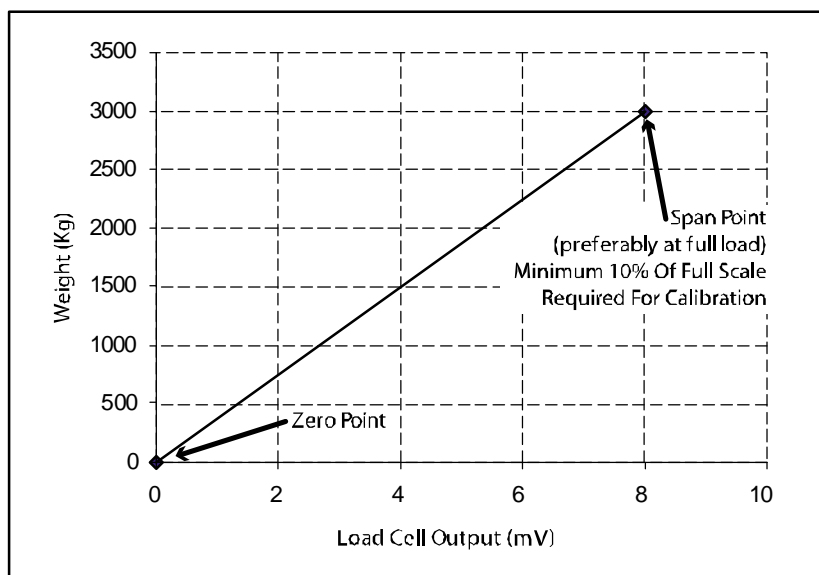

**Figure 11: Chart - Zero and Span Points to Interpolate Weight from Load Cell**

The Zero setting (SCALE:CAL:ZERO) specifies a gross zero point for the scale. The Span setting (SCALE:CAL:SPAN) specifies a second point (**preferably close to full scale**) used to convert the A/D readings into weighing units (eg. kg). The Tilt calibration (SCALE:CAL:TILT K491 only) compensates for errors due to inclination. It is important that an initial ZERO calibration is performed before any SPAN calibrations. TILT calibration (K491 only) must only be performed after both ZERO and SPAN calibrations are complete. The chart shown here demonstrates how the zero and span points are used to interpolate a weight reading from the load cell reading.

**Notes:**

1. Calibration points (Zero, Span and Linearisation) must be spaced by at least 2% of Full scale from each other.
2. First span point must be 10% of full scale or greater for successful calibration.

8.1.1. ZERO (Zero Calibration Routine)

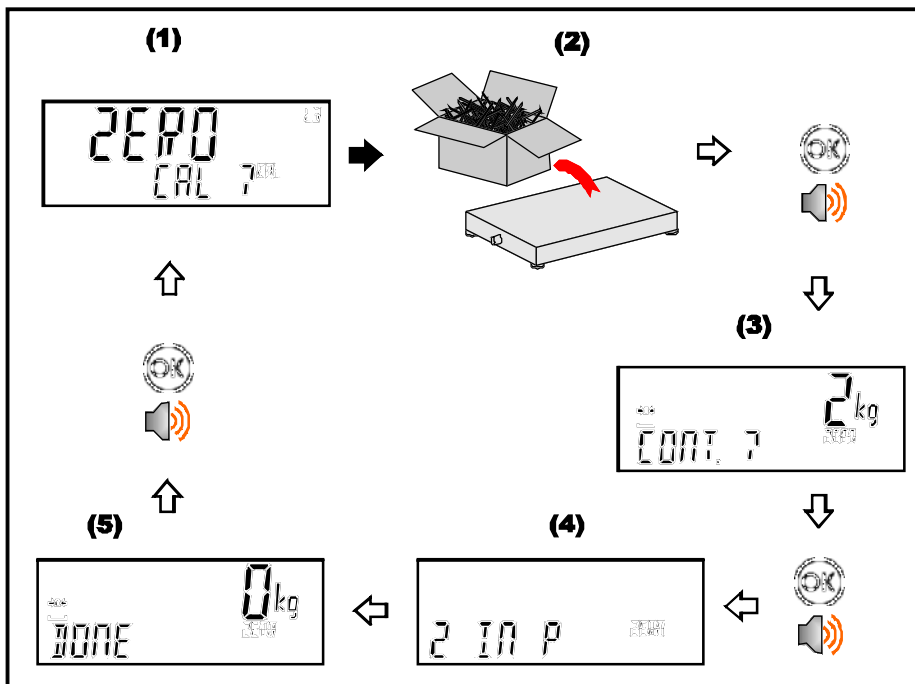

**Note (K491 only):**

Zero Calibration must be performed on a level surface. The closer the surface is to perfectly level, the more accurate the tilt compensation will be.

During Zero Calibration, the tilt sensor is automatically set to zero. If the tilt sensor has been previously calibrated, restore the factory zero of the tilt sensor (HWARE:TILT.HW:F.ZERO) before zero calibrating the system.

8.1.2. SPAN (Span Calibration Routine)

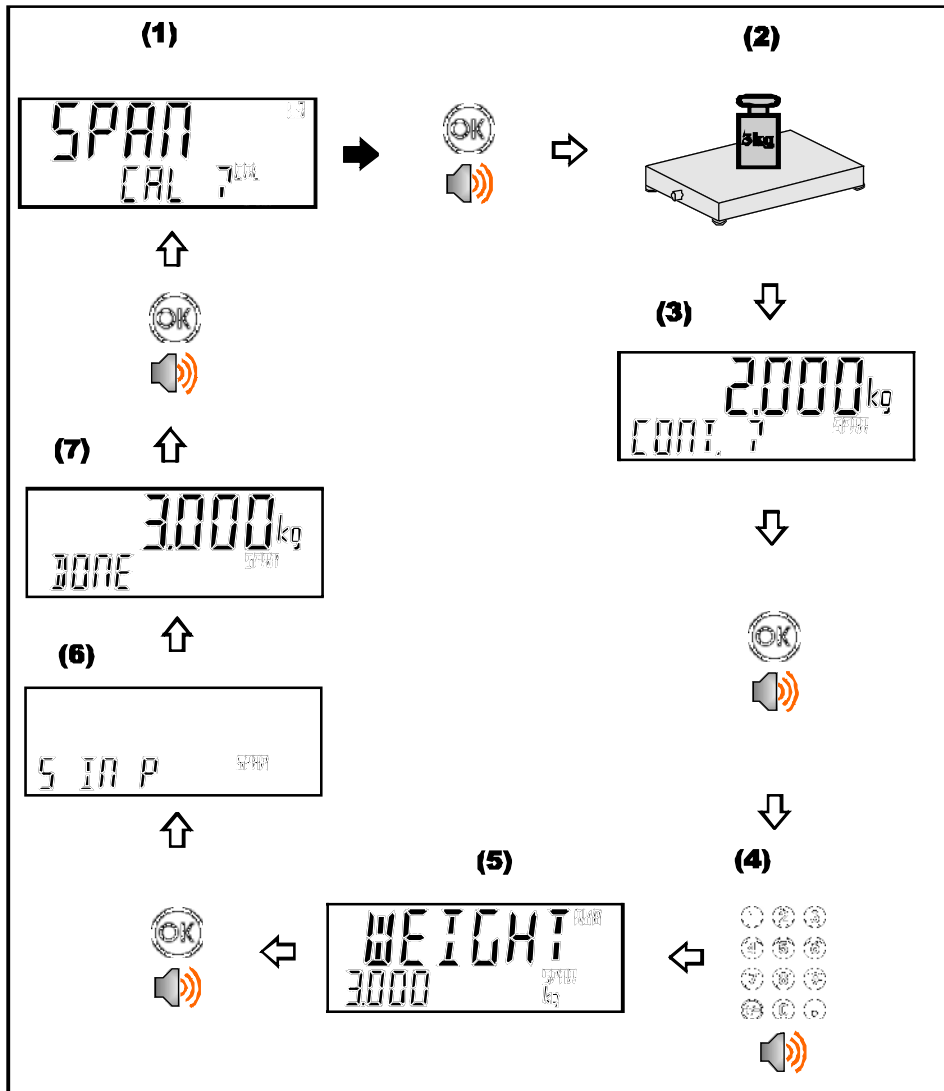

**Note (K491 only):**

Span Calibration must be performed on a level surface. The closer the surface is to perfectly level, the more accurate the tilt compensation will be.

8.1.3. TILT (Tilt Calibration Routine K491 only)

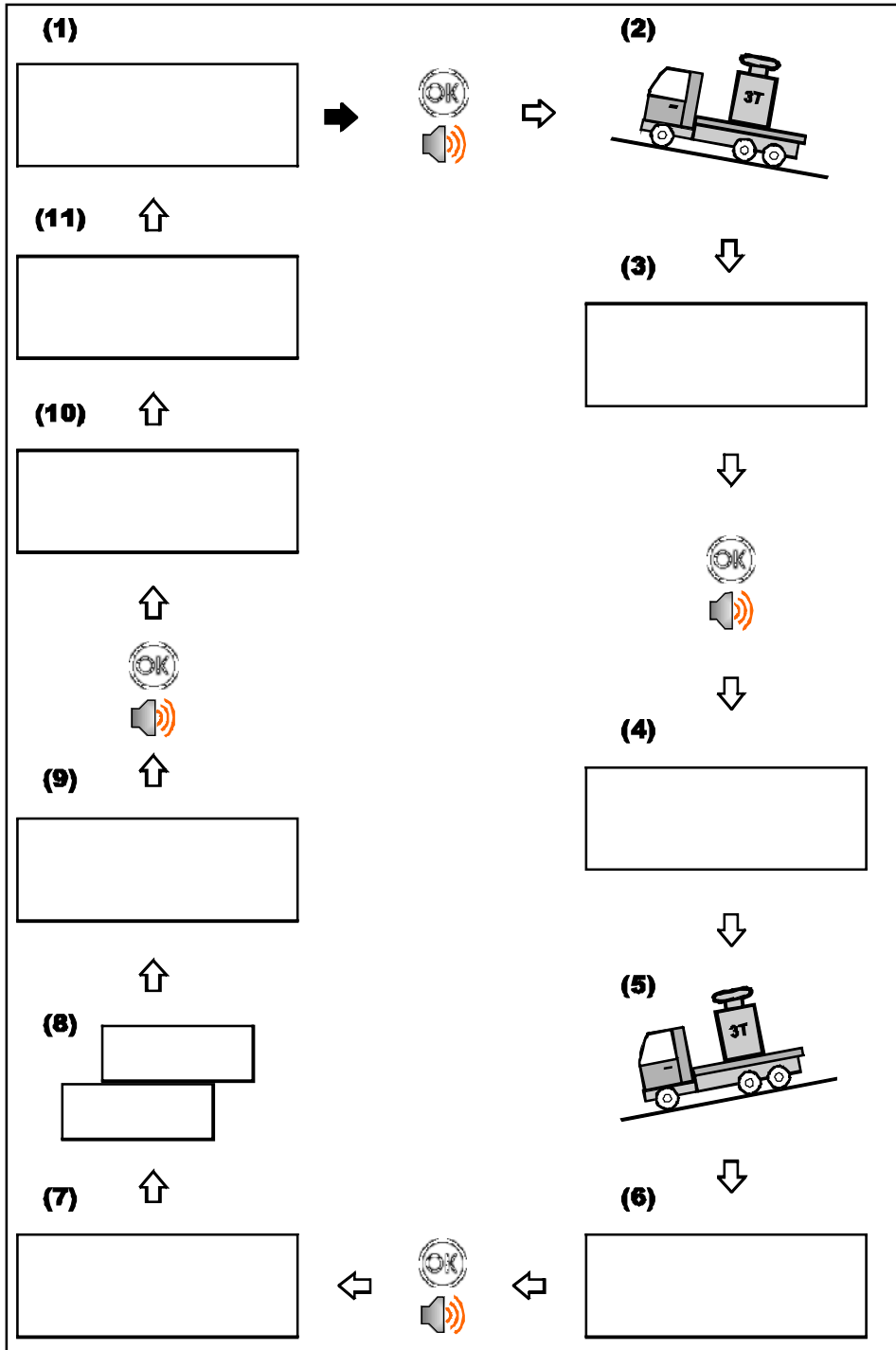

**Note:**

For example, "X+ Y0" indicates that the truck must be parked on an incline such that the X angle is greater than 2/3 of the Maximum Tilt (SCALE:BUILD:MAX.TLT), and the Y value is as close as possible to zero. The closer the Y value is to zero, the more accurate the compensation will be. The maximum allowed Y value for Y0 varies based on the number of divisions the scale has been calibrated to. If the required conditions are not met, an error will be displayed on the screen.

For Example:

If the scale is calibrated to less than 2300 divisions, the maximum Y angle allowed for Y0 is  $\pm 1.0$  Degrees.

If the scale is calibrated to greater than 9200 divisions, the maximum Y angle allowed for Y0 is  $\pm 0.4$  Degrees.

If required, the order of the above calibration steps can be changed using the up and down keys. Once a calibration step is completed, it will have "DONE" shown at the top right corner of the display. The indicator will not allow the tilt compensation procedure to commence until all of the 4 axis have been captured.

If required the data captured for each step can be viewed by pressing the +/- key, this will cycle through the live tilt values, the live mV/V value and the stored values (mV/V bottom left, angle bottom right). At the tilt start screen you can view the zero and span mV/V values as well as the span weight by pressing the +/- key.

## 8.2. Performing a Calibration with Direct mV/V Entry

In applications where test weights are not easily available, it is possible to calibrate the instrument directly by entering the mV/V signal strength at Zero and Span. The Direct Zero setting (SCALE:CAL:DIR.ZER) specifies a gross zero point for the scale. The Direct Span setting (SCALE:CAL:DIR.SPN) specifies the mV/V signal strength corresponding to an applied mass. This calibration technique is not compatible with linearisation. Clearly the accuracy of this type of calibration is limited to the accuracy of the direct mV/V data.

### 8.2.1. DIR.ZER (Direct Zero Calibration Entry)

Press the <OK> key to start. The display will show the current weight.
Press the <OK> key. Change the mV/V setting to the correct value for Zero and press the <OK> key. <b>DONE</b> will be displayed along with the weight to allow the reading to be checked.
Press the <OK> to leave the zero routine.

### 8.2.2. DIR.SPN (Direct Span Calibration Entry)

Press the <OK> key to start. The display will show the current weight.
Press the <OK> key. Change the weight to the correct value and press the <OK> key.
Change the mV/V setting to the correct value and press the <OK> key. <b>DONE</b> will be displayed along with the weight to allow the reading to be checked.
Press the <OK> to leave the zero routine.

### 8.3. Using Linearisation

Linearisation is used to approximate the weight output to a non-linear scale. The chart below shows a non-linear characteristic for the load cell output. From the chart, it can be seen that the trace with no linearisation applied is a poor approximation to the real characteristic. By applying one or more linearisation points, more accurate weight readings can be achieved.

**Figure 12: Chart - Non-Linear Characteristic for Load Cell Output**

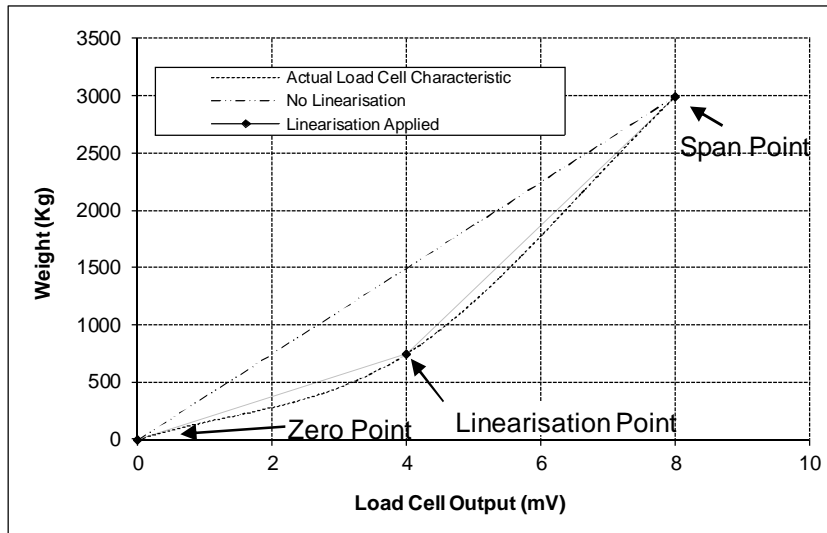

To perform a linearisation, a calibration of the zero and full scale span points must have been performed. Both the zero and full scale calibration points are used in the linearisation of the scale base. These two points are assumed to be accurately set and thus have no linearisation error.

A maximum of ten linearisation points can be set independently between zero and full scale. Unused or unwanted points may also be cleared. The maximum correction that can be applied using a linearisation point is + / - 2%.

8.3.1. ED.LIN (Edit Linearisation Points)

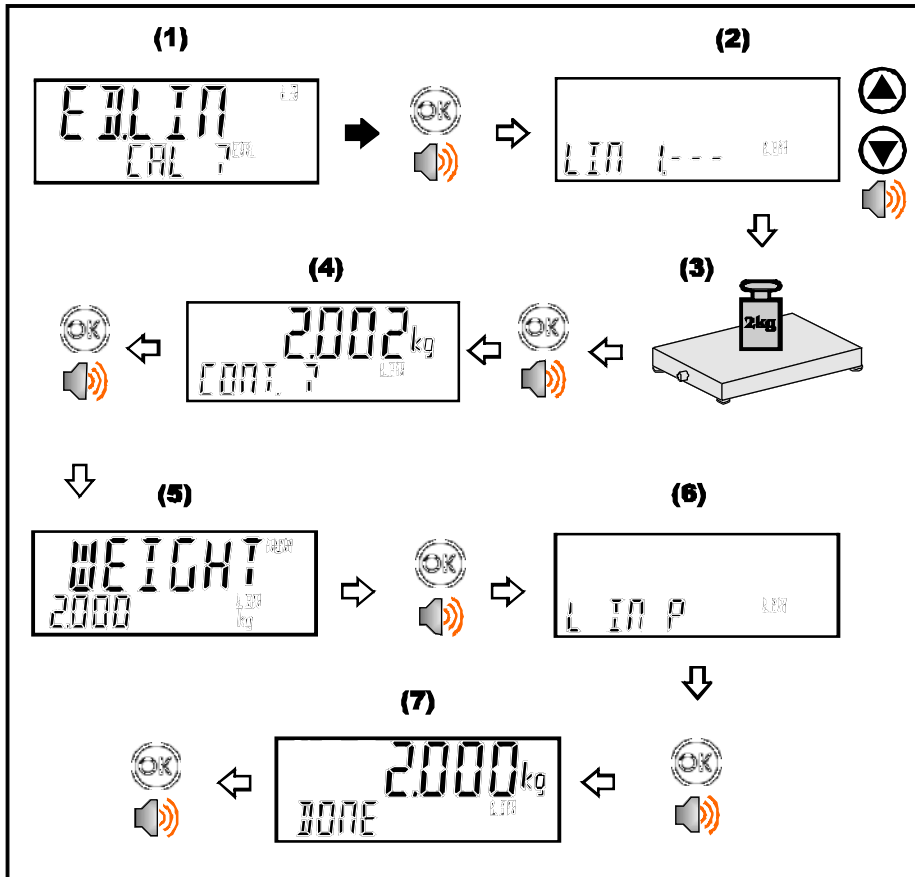

8.3.2. CLR.LIN (Clear Linearisation)

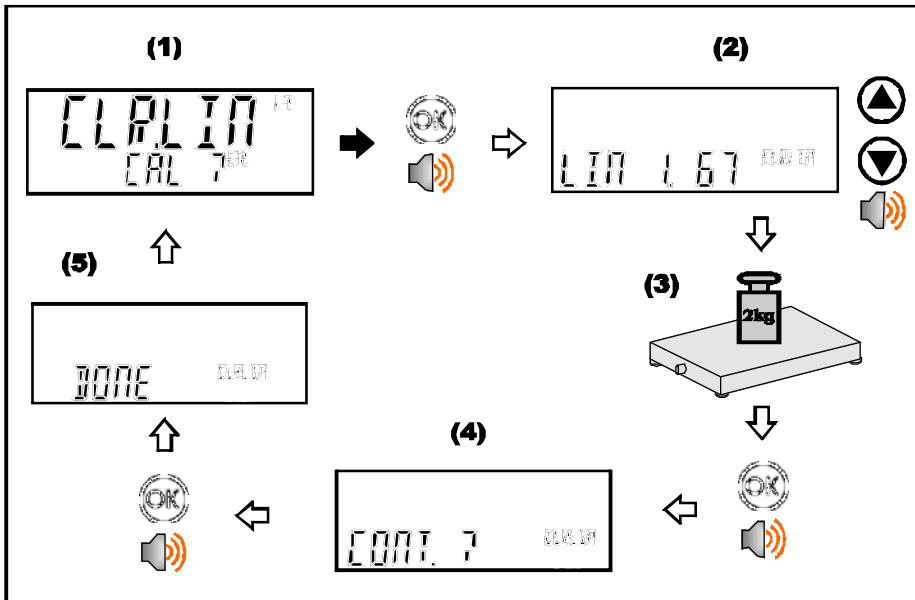

#### 8.4. Calibration Errors

Following are a list of the possible error messages that may be displayed to warn of failed or incorrect calibration:

<b>Error</b>	<b>Description</b>	<b>Resolution</b>
(FAILED) (BAND)	An attempt has been made to calibrate with a weight or signal which is not in the valid range.	Check weights and retry.
(FAILED) (ERROR)	An attempt has been made to calibrate while the scale signal is not valid.	Check loadcell connection and the 4-wire/6-wire setting.
(FAILED) (TIMEOUT)	For an unknown reason, the calibration was unable to complete.	Retry.
(FAILED) (RES)	An attempt has been made to calibrate the scale to a resolution which is too high for the instrument.	Check weights and retry.
(FAILED) (TOO CLOSE)	An attempt has been made to add a linearisation point too close to zero, span or another linearisation point.	Check weights and retry.
Y ANGLE LOW	The Angle of the truck is too low in the Y axis.	Adjust truck angle and retry.
Y ANGLE HIGH	The Angle of the truck is too high in the Y axis.	Adjust truck angle and retry.
X ANGLE LOW	The Angle of the truck is too low in the X axis.	Adjust truck angle and retry.
X ANGLE HIGH	The Angle of the truck is too High in the X axis.	Adjust truck angle and retry.

**Table 4: Calibration errors**

### 8.5. Tilt Calibration Errors (K491 only)

Following are a list of possible error messages that may be displayed to warn you of a failed tilt calibration.

Error	Axis / Tilt direction	Description	Details
X A HI	X	TILT.A exceeded the maximum value	The calibration requires that TILT.A exceed its maximum value of 3. There may be problems with the loadcells or calibration process.
X C HI	X	TILT.C exceeded the maximum value	The calibration requires that TILT.C exceed its maximum value of 5°. There may be problems with the scale construction, loadcells or the calibration process.
X C LO	X	TILT.C below the minimum value	The calibration requires that TILT.C is below its minimum value of -5°. There may be problems with the scale construction, loadcells or the calibration process.
X NO CONV	X	Calibration could not converge	No combination of TILT.A and TILT.C values could be found that produced a successful calibration. There may be problems with the scale construction, loadcells or the calibration process.
Y B HI	Y	TILT.B exceeded the maximum value	The calibration requires that TILT.B exceed its maximum value of 3. There may be problems with the loadcells or calibration process.
Y D HI	Y	TILT.D exceeded the maximum value	The calibration requires that TILT.D exceed its maximum value of 5°. There may be problems with the scale construction, loadcells or the calibration process.
Y D LO	Y	TILT.D below the minimum value	The calibration requires that TILT.D is below its minimum value of -5°. There may be problems with the scale construction, loadcells or the calibration process.
Y NO CONV	Y	Calibration could not converge	No combination of TILT.B and TILT.D values could be found that produced a successful calibration. There may be problems with the scale construction, loadcells or the calibration process.

**Table 5: Tilt Calibration errors**

## 9. Network Communications

### 9.1. Introduction

The RS-232, RS-485, Ethernet and the optical communications can be used for networking.

**Warning:** The calibration counter is incremented when the calibration related settings are changed. This means that calibration via a serial port cannot be carried out without affecting the certification of a trade installation.

Serial communications parameters like BAUD, PARITY, etc for the RS232 or RS485 serial ports are setup in the HDWARE menu.

The Optical Communications port is fixed to operate at 9600 baud, no parity, 8 data bits and 1 stop bit. The optical communications cable must be used.

### 9.2. Network Protocol B

The network protocol uses ASCII characters with a single master POLL / RESPONSE message structure. All information and services are provided by registers each of which has its own register address.

#### 9.2.1. Basic Message Format

The basic message format is as follows:

<b>ADDR</b>	<b>CMD</b>	<b>REG</b>	<b>:DATA</b>	<b>8</b>
-------------	------------	------------	--------------	----------

#### ADDR

ADDR is a two character hexadecimal field corresponding with the following:

ADDR	Field Name	Description
80 <sub>H</sub>	Response	'0' for messages sent from the master (POLL). '1' for messages received from an instrument (RESPONSE)
40 <sub>H</sub>	Error	Set to indicate that the data in this message is an error code and not a normal response.
20 <sub>H</sub>	Reply Required	Set by the master to indicate that a reply to this message is required by any slave that it is addressed to. If not set, the slave should silently perform the command.
00 <sub>H</sub> .. 1F <sub>H</sub>	Indicator Address	Valid instrument addresses are 01 <sub>H</sub> to 1F <sub>H</sub> (1 .. 31).  00 <sub>H</sub> is the broadcast address. All slaves must process broadcast commands. When replying to broadcasts, slaves reply with their own address in this field.

**CMD** is a two character hexadecimal field:

<b>CMD</b>	<b>Command</b>	<b>Description</b>
05 <sub>H</sub>	Read Literal	Read register contents in a 'human readable' format
11 <sub>H</sub>	Read Final	Read register contents in a hexadecimal data format
16 <sub>H</sub>	Read Final (Decimal)	Same as Read Final except numbers are decimal.
12 <sub>H</sub>	Write Final	Write the DATA field to the register.
17 <sub>H</sub>	Write Final (Decimal)	Same as Write Final except numbers are decimal.
10 <sub>H</sub>	Execute	Execute function defined by the register using parameters supplied in the DATA field.

<b>REG</b>	is a four character hexadecimal field that defines the address of the Register specified in the message. See Appendix 3: Communications Registers page 123 for a list of registers used by the instrument. The viewer software will show the register address for each setting in the menu structure when they are accessed.
<b>: DATA</b>	carries the information for the message. Some messages require no DATA (eg Read Commands) so the field is optional. When a DATA field is used a ':' (COLON) character is used to separate the header (ADDR CMD REG) and DATA information.
8	is the message termination (CR LF or “;”).

**Note:** The hexadecimal codes are combined in the fields described above when multiple options are active at the same time. For example an error response message from instrument address 5 would have an ADDR code of C5<sub>H</sub> (80<sub>H</sub> + 40<sub>H</sub> + 05<sub>H</sub>).

### 9.2.2. Termination

Message termination is possible in two ways.

- For normal communications that do not involve checksums use either a CRLF (ASCII 13, ASCII 10) as a terminator or a semicolon (;' ASCII ). There is no start-of-message delimiter.
- To use a checksum the message is framed as:

**SOH <Message> CRC EOT**

<b>SOH</b>	ASCII 01
<b>CRC</b>	a 4 character hexadecimal field comprising the 16 bit CRC checksum. The CRC uses the 16 bit CCITT polynomial calculation and includes only the contents of the <Message> section of the transmission.
<b>EOT</b>	ASCII 04

### 9.2.3. Error Handling

If a command cannot be processed, the indicator returns an error. The ERROR bit in the ADDR field is set and the DATA field contains the Error Code as follows:

Error	DATA	Description
Unknown Error	C000 <sub>H</sub>	Error is of unknown type
Not Implemented Error	A000 <sub>H</sub>	Feature not implemented on this device
Access Denied	9000 <sub>H</sub>	Passcode required to access this register
Data Under Range	8800 <sub>H</sub>	Data too low for this register
Data Over Range	8400 <sub>H</sub>	Data too high for this register
Illegal Value	8200 <sub>H</sub>	Data not compatible with this register
Illegal Operation	8100 <sub>H</sub>	CMD field unknown
Bad parameter	8040 <sub>H</sub>	Parameter not valid for this execute register
Menu in Use	8020 <sub>H</sub>	Cannot modify register values while SETUP menus are active
Viewer Mode required	8010 <sub>H</sub>	Advanced operation chosen which requires the instrument to be in viewer mode.
Checksum required	8008 <sub>H</sub>	A checksum is required for the chosen command.

**Table 6: Network error codes**

### 9.2.4. Ring Network Enhancement

Instruments with software revision V2.31+ can be configured in a Ring Network via a M42xx module (software revision 1.01+). This requires the central computer to send additional framing characters, 'Echo-On' (= <DC2> =ASCII 12 H) and 'Echo-Off' (= <DC4> =ASCII 14 H) around each command. Below is an example Ring Network command and response with two indicators:

#### COMMAND

```
<DC2>20110150:<CR><LF>
<DC4>
```

#### RESPONSE

```
<DC2>20110150:<CR><LF>
81110150:07/01/2030 17-29<CR><LF>
82110150:07/01/2030 17-30<CR><LF>
<DC4>
```

### 9.2.5. Calibrating an instrument over a network

An instrument can be calibrated over a network using the network protocol. The registers relating to calibration are listed in Appendix 3: Communications Registers page 123 and marked with the symbol “\*”. Note that changing the calibration of an instrument via the network will increment the calibration counters and void the scale certification.

These registers are protected by the full access passcode if it is being used. In this case, the Enter Full Passcode register is necessary in the process of calibration. If the rear button is used to access the menus normally, then a long press of the rear button will enter a mode that permits calibration via the network.

### 9.3. Network Protocol USER.DEF (K403 only)

The user defined network protocol allows the indicator to be used in legacy systems where the indicator must respond to a command that is not in the format of Protocol B. A custom input can be defined as well as an equivalent Protocol B command.

When the user defined network protocol matches the input in the INP.1 setting it will then interpret the Protocol B command in CMD.1. Below is an example of a simple command and response.

INP.1: \02W?\03

CMD.1: 2012004D:\BE\AA\96\A4\D7\C1\03

With the above example when the instrument receives <STX>W?<ETX> it will respond with the displayed weight in the format:

001000<CR><LF>

Notes:

1. Only one command (CMD.1) can be interpreted and it must be a fully formed Protocol B network command.
2. To send any of the characters used by the Protocol B network parser (<STX>, <CR>, <LF>, <SOH>, <EOH>, <ETX>, ;) they need to be double escaped. To change the above example to send the weight <STX><ETX> framed change CMD.1 to 2012004D:\02\BE\AA\96\A4\D7\03\03.

See section 16.3 Tokens on page 119 for information on the print tokens used in the above example.

## 9.4. Network Protocol SIMPLE

The simple network protocol allows the indicator to respond to common simple ASCII key press commands and enable the indicator to be used in legacy systems.

The response setting (RESP) defines if there is any response sent to successful commands. A setting of OK will send OK<CR> on successful receipt of command or ??<CR> if the command is not understood.

Function	Simple commands
Zero Key	Z<CR>, %z, \FAh, KZERO<CR>, MZ<CR>, m<CR>, KZ00<CR>(*), @00CZER<CR>(*), @00MZ<CR>(*)
Tare Key	T<CR>, %t, \F4h, KTARE<CR>, MT<CR>, t<CR>, KT00<CR>(*), @00CTAR<CR>(*), @00MT<CR>(*)
Gross/Net Key	%s, \F3h, KGROSSNET<CR>, KG00<CR>(*)
To Gross	G<CR>, 0%s, KGROSS<CR>, MG<CR>, C<CR>, r, @00CGRS<CR>(*), @00MG<CR>(*)
To Net	N<CR>, 1%s, KNET<CR>, MN<CR>, n<CR>, @00CNET<CR>(*), @00MN<CR>(*)
Print Key	%p, \F0h, KPRINT<CR>, KP00<CR>(*)
Single	P<CR>, W<CR>, \05h, \95h, \96h, S<CR>, H<CR>, R<CR>, Q<CR>, RW<CR>, Kp00<CR>(*), @00RDSP<CR>(*), @00RW<CR>(*)
0..9 Keys	0, 1, 2, 3, 4, 5, 6, 7, 8, 9, ., K0<CR>, K1<CR>, K2<CR>, K3<CR>, K4<CR>, K5<CR>, K6<CR>, K7<CR>, K8<CR>, K9<CR>, KDOT<CR>
OK Key	%e, \E5h, \0Dh, KENTER<CR>
Cancel Key	\1Bh

\* 00 is the broadcast address, this can be changed to an individual instruments address.

## 9.5. Network Protocol BARCODE

The barcode network protocol allows a barcode scanner to be connected to the instrument to select the product. The source setting allows the product to be selected based on its name, barcode or ID number. To select the example product:

Name: abcdefghi  
Barcode: 123456789abcd  
ID: 200

With barcode protocol source set to NAME send:  
abcdefghi <CR><LF>

With barcode protocol source set to BARCODE send:  
123456789abcd<CR><LF>

With barcode protocol source set to ID send:  
200<CR><LF>

## 9.6. Protocol B Examples

Read Gross Weight (Read Final)	Description
<b>COMMAND:</b> 201100268 <b>RESPONSE:</b> 81110026:000000648	<b>COMMAND:</b> Read Gross Weight (Register 0026): ADDR = 20 <sub>H</sub> : Reply required from any instrument CMD = 11 <sub>H</sub> : Read Final REG = 0026 <sub>H</sub> : Gross Weight <b>RESPONSE:</b> Response is from instrument #1 which currently has a Gross weight of 64 <sub>H</sub> = 100 kg.
<b>COMMAND:</b> 200500268 <b>RESPONSE:</b> 81050026: 100 kg 8	<b>COMMAND:</b> Read Gross Weight (Register 0026 <sub>H</sub> ): ADDR = 20 <sub>H</sub> : Reply required from any instrument CMD = 05 <sub>H</sub> : Read Literal REG = 0026 <sub>H</sub> : Gross Weight <b>RESPONSE:</b> Same response from instrument #1 but in literal format.
<b>COMMAND A:</b> 2112A381:Hello There8 <b>RESPONSE A:</b> C112A381:90008  <b>COMMAND B:</b> 2112001A:4D28 <b>RESPONSE B:</b> 8112001A:00008  <b>COMMAND C:</b> 2112A381:Hello There8 <b>RESPONSE C:</b> 8112A381:00008  <b>COMMAND D:</b> 211000108 <b>RESPONSE D:</b> 81100010:00008	<b>COMMAND A:</b> Write Print Header String (Register A381 <sub>H</sub> ) ADDR = 21 <sub>H</sub> : Reply required from instrument #1 CMD = 12 <sub>H</sub> : Write Final REG = A381 <sub>H</sub> : Print Header String DATA = 'Hello There' <b>RESPONSE A:</b> Instrument #1 reports "ERROR: Access Denied". (Writing to this register requires a passcode) <b>COMMAND B:</b> Enter SAFE SETUP Passcode (Register 1A <sub>H</sub> ) ADDR = 21 <sub>H</sub> : Reply required from instrument #1 CMD = 12 <sub>H</sub> : Write Final REG = 1A <sub>H</sub> : Enter SAFE PASSCODE DATA = 4D2 <sub>H</sub> (passcode is 1234) <b>RESPONSE B:</b> Instrument #1 reports Passcode Accepted <b>COMMAND C:</b> (resend COMMAND A). <b>RESPONSE C:</b> Instrument #1 reports "Command Successful". <b>COMMAND D:</b> Save Settings (Register 10 <sub>H</sub> ) ADDR = 21 <sub>H</sub> : Reply required from instrument #1 CMD = 10 <sub>H</sub> : Execute REG = 10 <sub>H</sub> : Save Settings <b>RESPONSE D:</b> Instrument #1 reports "Command Successful".

Trigger Zero Button Press (Write Final)	Description
<p>COMMAND A: 21120008:0E8 RESPONSE A: 81120008:00008</p> <p>COMMAND B: 21120008:8E8 RESPONSE B: 81120008:00008</p>	<p>COMMAND A: Send down the Zero button key code.</p> <p>RESPONSE A: Instrument #1 reports "Command Successful".</p> <p>COMMAND B: Do a long press of the F1 key.</p> <p>RESPONSE B: Instrument #1 reports "Command Successful".</p>
<p><b>Streaming (Write Final, Read Final, Execute)</b></p> <p>COMMAND A: 21120042:068 RESPONSE A: 81120042:00008</p> <p>COMMAND B: 21120043:118 RESPONSE B: 81120043:00008</p> <p>COMMAND C: 211100408 RESPONSE C: 81110040:000005DB000 000098</p> <p>COMMAND D: 21120041:038 RESPONSE D: 81120041:00008</p> <p>COMMAND E: 21100040:18 RESPONSE E: 81100040:000000008 81110040:000005DB000 000098 81110040:000005DB000 000098</p> <p>COMMAND G: 21100040:08 RESPONSE G: 81100040:000000008</p>	<p>COMMAND A: Setup to read the displayed weight.</p> <p>RESPONSE A: Instrument #1 reports "Command Successful".</p> <p>COMMAND B: Setup to read the IO status.</p> <p>RESPONSE B: Instrument #1 reports "Command Successful".</p> <p>COMMAND C: Read the combined data.</p> <p>RESPONSE C: Data is concatenated. It is 8 hexadecimal digits each.</p> <p>COMMAND D: Set streaming to 3Hz.</p> <p>RESPONSE D: Instrument #1 reports "Command Successful".</p> <p>COMMAND E: Start the automatic streaming.</p> <p>RESPONSE E: Instrument #1 reports "Command Successful" followed by streamed data at 3Hz.</p> <p>COMMAND G: Stop the automatic streaming.</p> <p>RESPONSE G: Instrument #1 reports "Command Successful".</p>

## 10. Automatic Weight Output

### 10.1. Overview

The automatic output is normally used to drive remote displays, a dedicated computer, or PLC communications. It is configured using the **SER.AUT** menu. The RS-232 or the RS-485 port can be used.

The rate of transmission is set by the TYPE setting. AUTO.LO and AUTO.HI send unsolicited messages at 10Hz and 25Hz respectively. SINGLE only sends messages when a SINGLE input is received from an external input. This enables external systems like PLCs to synchronise the AUTO output to their requirements. AUT.TRC sends a message for every traceable weight and is usually combined with FMT.TRC to provide a tally roll printer log.

### 10.2. Auto Weight Format String

The weight format string may be set to the following formats:

Format	Description
FMT.A	<STX> <SIGN> <WEIGHT(7)> <STATUS> <ETX>
FMT.B	<STX> <S0> <SIGN> <WEIGHT(7)> <UNITS(3)> <ETX>
FMT.C	<STX> <SIGN> <WEIGHT(7)> <S1> <S2> <S3> <S4> <UNITS(3)> <ETX>
FMT.D	<STX> <SIGN> <WEIGHT(7)> <ETX>
FMT.E	<STX> <SIGN> <WEIGHT(7)> <S5> <UNITS(3)> <MODE(4)> <ETX>
FMT.REG	ADDR CMD REG : DATA
FMT.TRC	CONSEC SP DATE SP TIME SP TRACE <CR><LF>
CUSTOM	As per contents of the EV.AUTO token string.

Where

- **STX**: Start of transmission character (ASCII 02).
- **ETX**: End of transmission character (ASCII 03).
- **SIGN**: The sign of the weight reading (space for positive, dash (-) for negative).
- **WEIGHT(7)**: A seven character string containing the current weight including the decimal point. If there is no decimal point, then the first character is a space. Leading zero blanking applies.
- **S0**: Provides information on the weight reading. The characters G/N/U/O/M/E represent Gross / Net / Underload / Overload / Motion / Error, respectively.
- **UNITS(3)**: A three character string, the first character being a space, followed by the actual units (eg. ^kg or ^t). If the weight reading is not stable, the unit string is sent as ^^.
- **S1**: Displays G/N/U/O/E representing Gross / Net / Underload / Overload / Error, respectively.
- **S2**: Displays M/^ representing Motion / Stable, respectively.
- **S3**: Displays Z/^ representing centre of Zero / Non-Zero, respectively.
- **S4**: Displays - representing single range.
- **S5**: Displays “/”m””c” representing Stable / Motion / Overload or Underload
- **Mode**: Displays “\_g\_” or “\_n\_” for gross or net weight.
- **‘ADDR CMD REG : DATA’**: This is the same format as the response from a READ FINAL network command. The SOURCE setting selects which register is selected.
- **SP**: Space character, “ “
- **CONSEC**: Consecutive print ID
- **DATE, TIME**: Date and time.
- **TRACE**: Traceable displayed weight.

## 11. Printing

### 11.1. Overview

The instrument can have up to two (2) printouts. There are three (3) types of printout:

- **RECORD:** Record printouts are essentially a single printout generated by a single print event.
- **DOCKET:** Docket printouts are comprised typically of the output of a number of print events. There is a start section that includes header information, followed by a number of transactions and finally the end of the docket including sub-total information etc.
- **REPORT:** Reports are used to print stored accumulation data for each product.

There are two different fixed formats for each printout type defined in the instrument. The format of these printouts is shown in the following sections.

For custom printing each print event has an associated token string which includes literal ASCII text along with special token characters that are expanded at the time of printing to fields like weight, time and date.

### 11.2. Print ID

A unique Consecutive Print ID appears on record printouts. It cannot be cleared and increments for every traceable weight reading. Additionally a Settable Consecutive Print ID is available through custom printing. It can be viewed and edited through the operator interface User ID key (long press key 5).

### 11.3. Record printouts

#### 11.3.1. K401

Format	Example
<b>FMT.A</b>	000000057 15/09/05 12:20:23 750kg G
<b>FMT.B</b>	Joe's Fruit & Veg 30 Yarmouth Pde Tamworth NSW 2040 01/01/2003 11:30 ID: 000000058 T: 5.0 kg G: 100.4 kg N: 95.4 kg Thank You!
<b>CUSTOM</b>	Format defined by REC.PRN token string.

#### 11.3.2. K402

Format	Example
<b>FMT.A</b>	001234 01/01/2003 11:30 100.4 kg G TOMATOES
<b>FMT.B</b>	Joe's Fruit & Veg

	30 Yarmouth Pde Tamworth NSW 2040 01/01/2003 11:30 ID: 001234 TOMATOES T: 5.0 kg G: 100.4 kg N: 95.4 kg Thank You!
<b>CUSTOM</b>	Format defined by REC.PRN token string.

### 11.3.3. Custom Record Events (K401 and K402)

There is one Custom Record Event that is associated with the pressing of the print key.

Action	Event	Event Description
Print Key	REC.PRN	Defines what is printed when the print key is pressed.

## 11.4. Docket printouts

### 11.4.1. K401

Format	Example
<b>FMT.A</b>	Joe's Fruit & Veg 30 Yarmouth Pde Tamworth NSW 2040 13/03/03 11:09:27 4.06 kg,      5.04 kg,      3.15 kg, 5.02 kg,      4.48 kg,      6.15 kg, Total      27.90 kg Items          6 Thank You!
<b>FMT.B</b>	Joe's Fruit & Veg 30 Yarmouth Pde Tamworth NSW 2040 13/03/03 11:09:27 4.06 kg 5.04 kg 3.15 kg 5.02 kg 4.48 kg 6.15 kg Total      27.90 kg Items          6 Thank You!
<b>CUSTOM</b>	EV.D.NEW PRN.KEY EV.P.END EV.P.NEW EV.D.END

## 11.4.2. K402

Format	Example
<b>FMT.A</b>	Joe's Fruit & Veg 30 Yarmouth Pde Tamworth NSW 2040 13/03/03 11:09:27 Onions 4.06 kg, 5.04 kg, 3.15 kg, Apples 5.02 kg, 4.48 kg, 6.15 kg, Total 27.90 kg Thank You!
<b>FMT.B</b>	Joe's Fruit & Veg 30 Yarmouth Pde Tamworth NSW 2040 13/03/03 11:09:27  Onions 4.06 kg 5.04 kg 3.15 kg Sub 12.25 kg  Apples 5.02 kg 4.48 kg 6.15 kg Sub 15.65 kg  Total 27.90 kg Thank You!
<b>CUSTOM</b>	EV.D.NEW PRN.KEY EV.P.END EV.P.NEW EV.D.END

## 11.4.3. Custom Docket Events (K401 and K402)

Custom Docket Events and associated operator actions:

Action	Event	Event Description
Print Key	EV.D.NEW	Event Docket New - controls the first part of the docket that is printed along with the first transaction.
	PRN.KEY	Event Print - controls the format of each transaction on the docket.
Change Product	EV.P.END	Event Product End* - generated when current product is changed
	EV.P.NEW	Event Product New - used when a new product is selected.
Long Press Print Key	EV.D.END	Event Docket End - controls the format of the end of the docket including printing sub-totals etc.

\* Note: The K401 supports one (1) product therefore these docket events will not be triggered.

## 11.5. Report printouts

Format	Example
<b>FMT.A</b>	13/03/2003 11:09:27 Grand Total Apples 5.65 kg Onions 2.25 kg Total 7.90 kg
<b>FMT.B</b>	13/03/2003 11:09:27 Grand Total Apples 5.65 kg, Onions 2.25 kg Total 7.90 kg
<b>CUSTOM</b>	REP.ST REP.PR REP.END

Custom Report Events and associated operator actions:

Action	Event	Event Description
Press Report Key	REP.ST	Report Start - defines the start of the report.
	REP.PR	Report Product **- defines what is printed for each product
Change Product	REP.END	Report End - defines the end of the report.

\*\* Note: REP.PR is for per product printing in the report and is not an event triggered by changing the product. If there is anything in the REP.PR then it will be printed for all products that have a total when the report is printed.

## 11.6. Custom Printing

A print docket is built up from multiple print passes. Each of the print passes is defined by a specific configuration string. Print passes are triggered by operator events – these include short and long press of the Print key and actions like changing products.

The content of the configuration string for each event includes direct text (the word “Weight” to be placed near the current weight for example) and control characters called ‘Tokens’. Tokens are used to specify where the instrument data fields are to be inserted.

Tokens are characters outside the normal printable range. Each token character is represented by a three character escape sequence consisting of a ‘\’ followed by two hex characters or by a three digit decimal ASCII number. When entering tokens via the instrument keys the decimal ASCII code is used. When entering tokens using the viewer software the escape sequence is used.

Examples of tokens:

\D7 (ASCII 215) = current displayed weight  
 \BF (ASCII 191) = date  
 \C0 (ASCII 192) = time

A simple custom format string might be:

'Weight: \D7\C1'

To produce Weight: 30.0kg ^ when the print key is pressed.

Events are triggered by short and long press of the Print key and changing products as listed as listed in the tables for each type.

Below are some examples of dockets and reports and their associated custom print strings.

Docket Example Print Outs	Custom Print Strings
Joe's Nuts 13/03/03 11:09:27 Peanuts 4.06 kg, 5.04 kg, Almonds 5.02 kg, 4.48 kg, Total 18.60 kg Thank You!	EV.D.NEW: \C3\C6\C1\BF \C0  PRN.KEY: \BA\E9,  EV.P.NEW: \C1\BA\D7  EV.P.END:  EV.D.END: \B8\C1Total: \DD\C1\C7\C1\C4
Joe's Nuts 13/03/03 11:09:27  Peanuts 4.06 kg 5.04 kg Sub 9.10 kg  Almonds 5.02 kg 4.48 kg Sub 9.50 kg  Total 18.60 kg Thank You!	EV.D.NEW: \C3\C6\C1\BF \C0\C1  PRN.KEY: \BA \E9\C1  EV.P.NEW: \C1\BA\D7\C1  EV.P.END: \BA Sub \DD\EC\C1  EV.D.END: \B8\C1Total \DD\C1\C7\C1\C4

Report Example Print Outs	Custom Print Strings
13/03/2003 11:09:27 Grand Total Peanuts 5.65 kg Almonds 2.25 kg Total 7.90 kg	REP.ST: \C3\BF \C0\C1Grand Total\C1  REP.PR: \BA\D7 \D9\C1  REP.END: Total \B8\D9\C1\C4
13/03/2003 11:09:27 Grand Total Peanuts 5.65 kg, Almonds 2.25 kg Total 7.90 kg	REP.ST: \C3\BF \C0\C1Grand Total\C1  REP.PR: \BA\D7 \D9,  REP.END: \C1Total \B8\D9\C1\C4

### 11.6.1. Page Tokens

The page number token must be used prior to the required token in the custom print string. For example the token D7 is used in both Page 0 and Page 4 and has different meanings.

Custom Print String:                    \**BE**\D7

Code		Token
190	(BE <sub>H</sub> )	Page 0: Current Weight
215	(D7 <sub>H</sub> )	Displayed reading (gross or net)

Custom Print String:                    \**BA**\D7

Code		Token
186	(BA <sub>H</sub> )	Page 4: Current Product
215	(D7 <sub>H</sub> )	Product name

Refer to Table 10: Print tokens: pages on page 119 for the list of codes for the tables and the various table are defined in section 16.3 Tokens page 119.

## 12. Special Functions

### 12.1. Introduction



The instrument has 3 special function keys on the front panel. The function of these keys can be configured to any of the key functions detailed below.



**<FUNCTION>** keys have no primary function pre-programmed. Each primary function has an associated overlay sticker (supplied) that should be applied to the function key to label the function. Ensure the keypad is clean and dry before affixing the sticker. Refer to Cleaning page 9 for more information.

### 12.2. Key Functions

#### 12.2.1. NONE

When set to **NONE** the special function key is not used during normal operation. This is the default setting.

#### 12.2.2. PRINT

A print key can be used to trigger any of the configured printouts. It can also add to totals or undo the last add. When docket printing, a long press ends the docket.

##### ◆ Short press

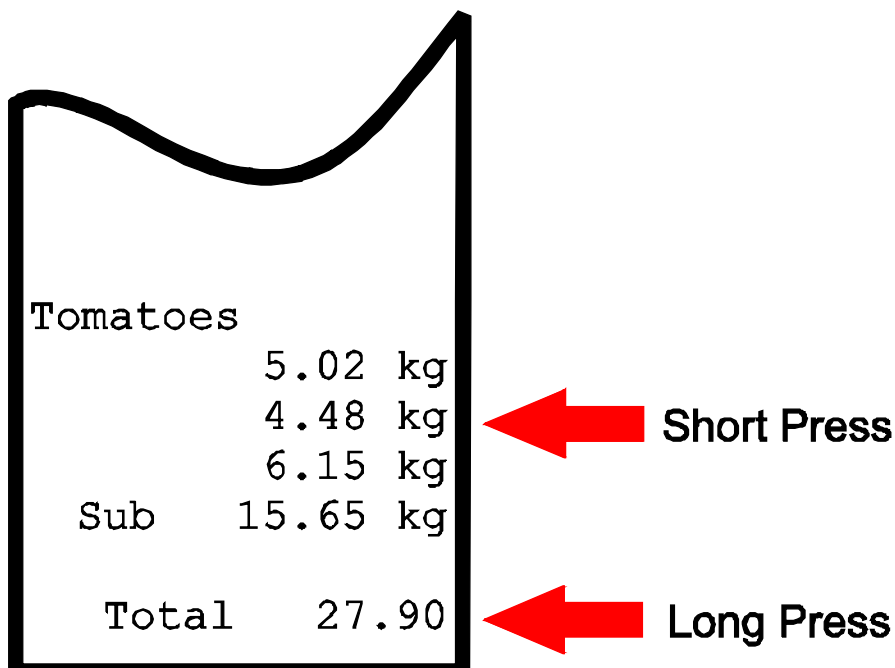
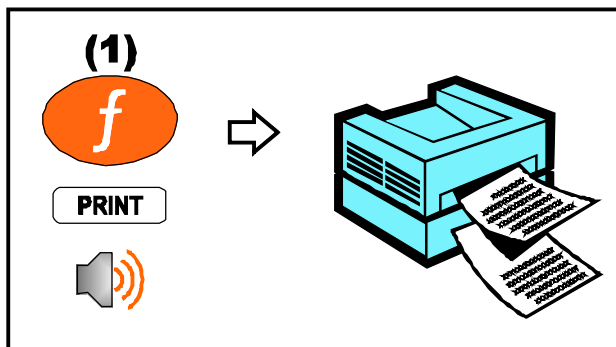

12.2.3. SINGLE

A single key is a manual trigger for the serial automatic transmit. A single automatic transmit string is sent when this key is pressed. This may be useful where a continual stream of serial data is not wanted.

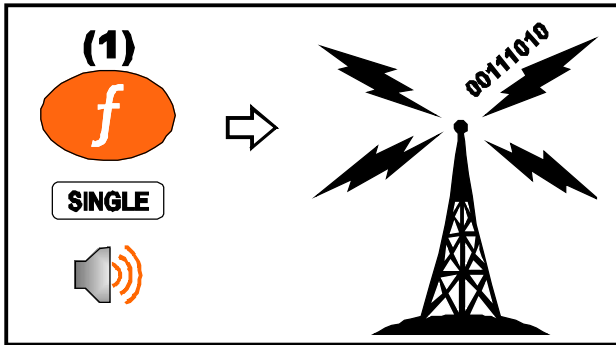

12.2.4. TEST

A test key is used to start a display test.

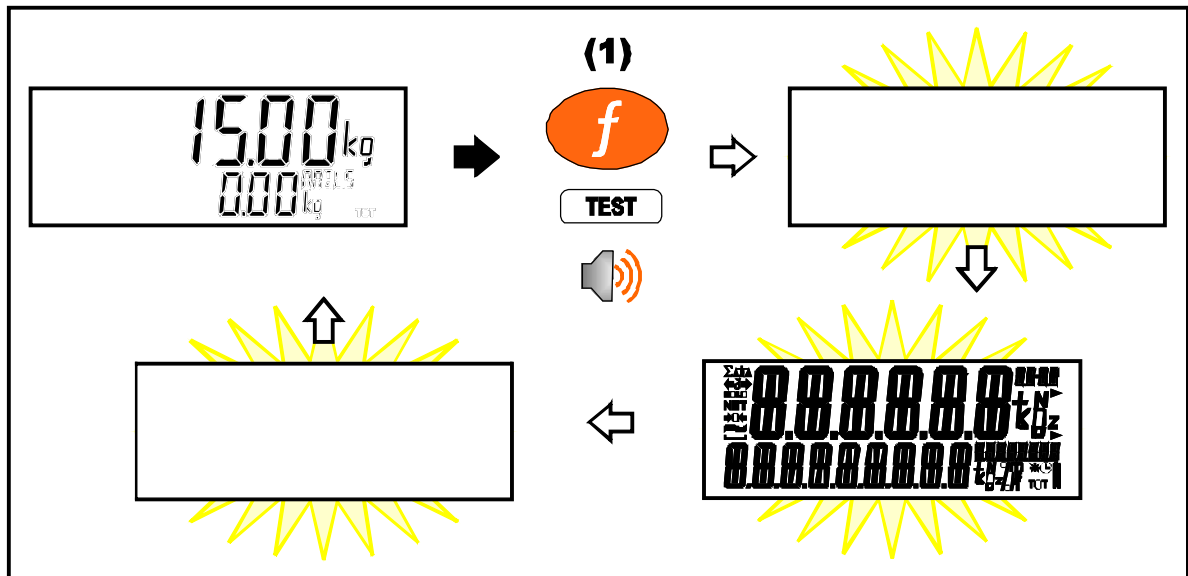

### 12.2.5. COUNT

A counting key is used to convert weight to number of items (pieces) on the scale.

◆ **Short press**

A short press switches the display between weight and pieces.

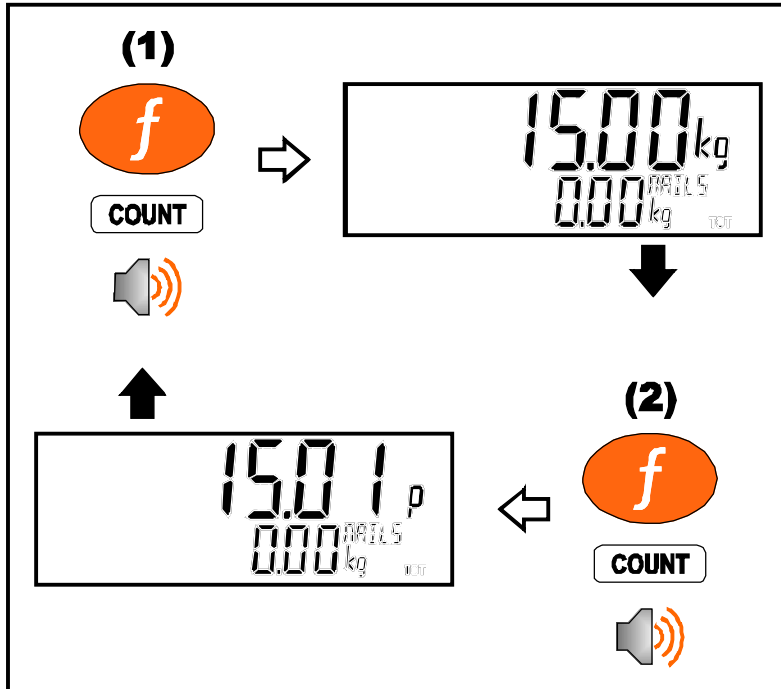

◆ **Long press**

A long press allows the sample size and weight to be changed.

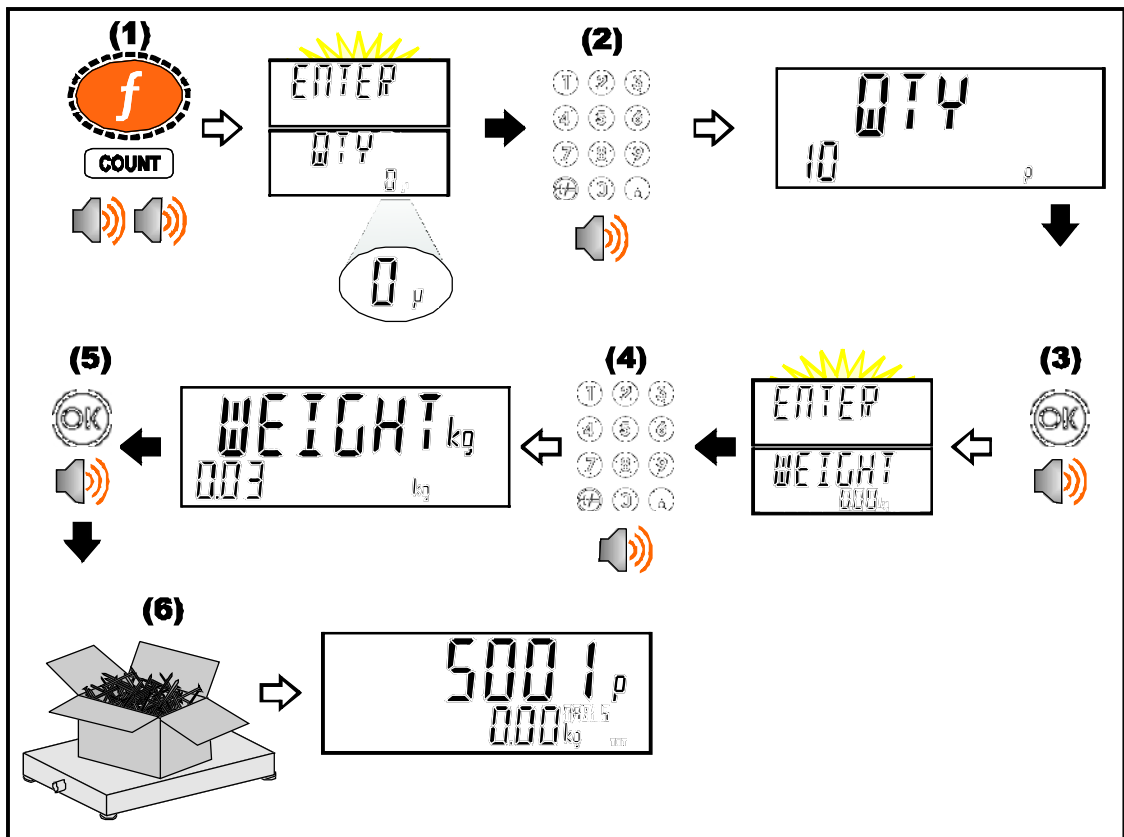

If EDT.WGT is set to OFF then the weight entry step shown above will be skipped and the current weight on the scale will be used. If EDT.CNT is set to OFF then the quantity entry step shown above will be skipped and a quantity of 100 will be used. If EDT.WGT is set to RESAMP then you can add more pieces and the indicator will adjust the piece weight as long as the change is less than the MAX.ADJ setting. If the resample was successful then the indicator will beep twice and store the new value, otherwise a long beep will sound and the new value will be discarded.

### 12.2.6. PIECE

A piece key is used to convert weight to number of items (pieces) on the scale. It is similar to a count key.

◆ **Short press**

A short press switches the display between weight and pieces.

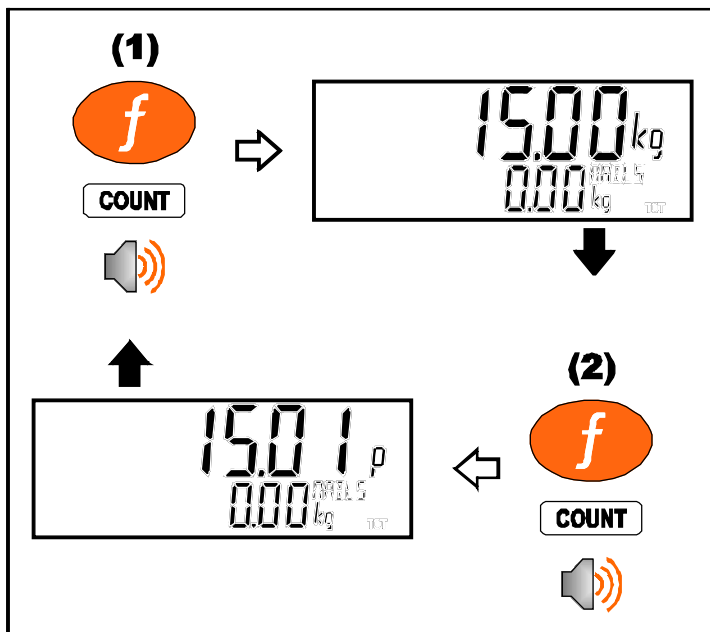

◆ **Long press**

A long press allows the piece weight to be entered.

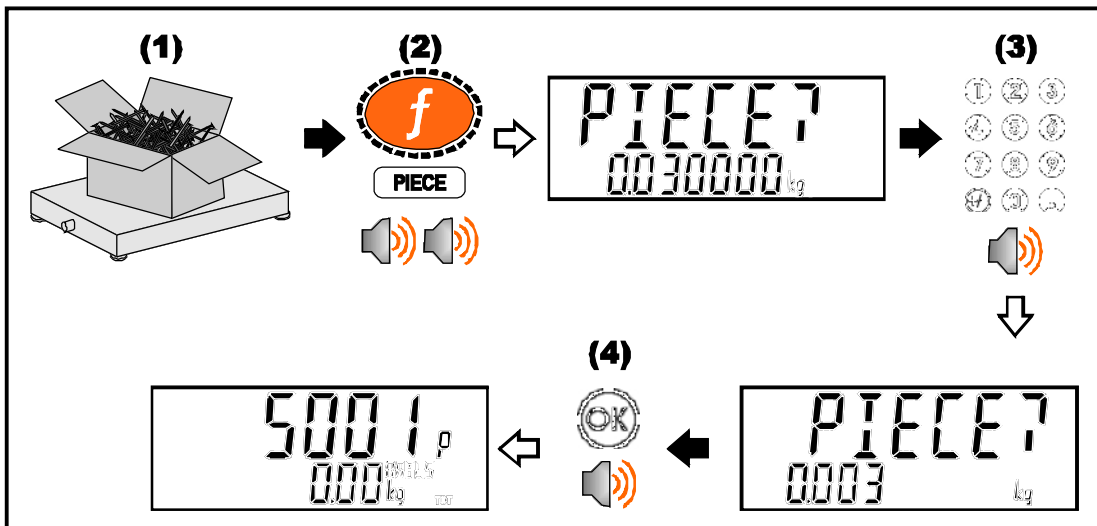

## 12.2.7. UNITS

The units key is used to convert primary (calibrated) units to alternative units.

### ◆ Short press

A short press switches between primary and alternative units.

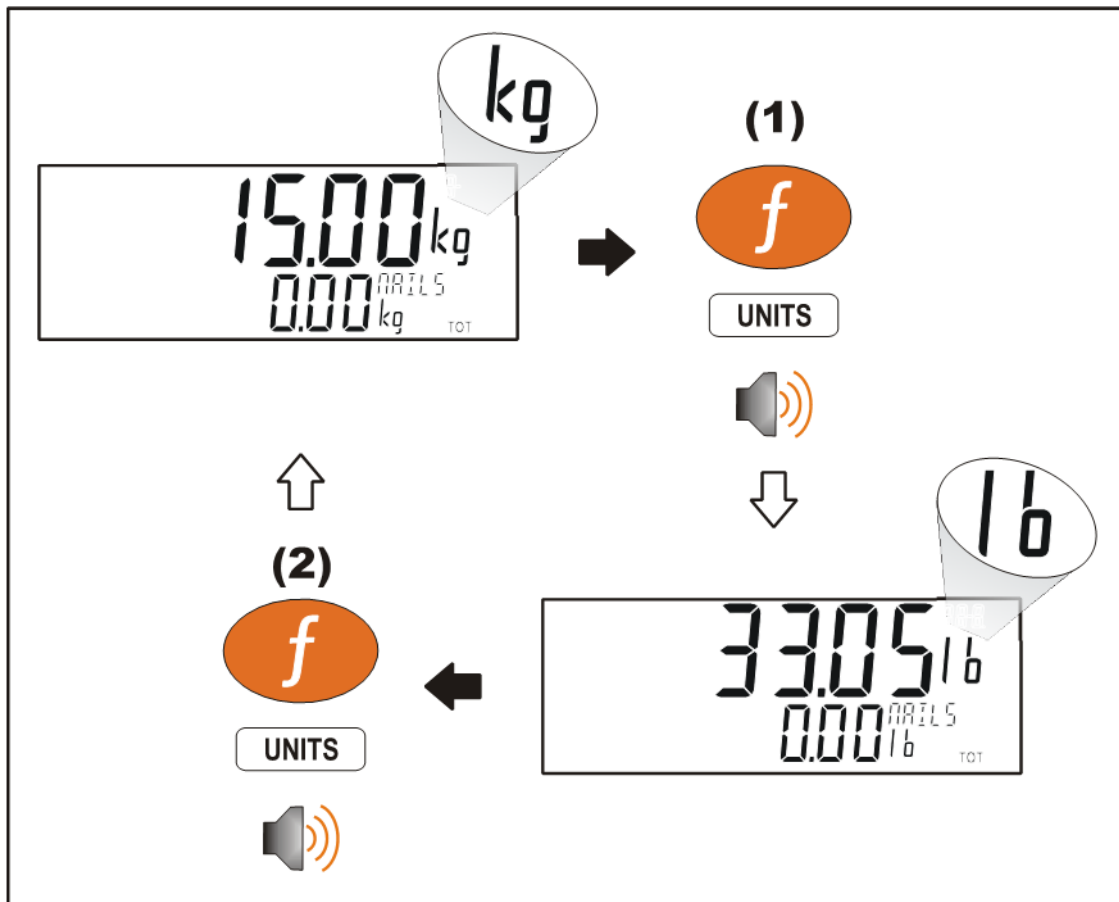

### ◆ Long press

A long press allows the units conversion factor to be entered. If lb/kg switching is chosen, this will be unavailable.

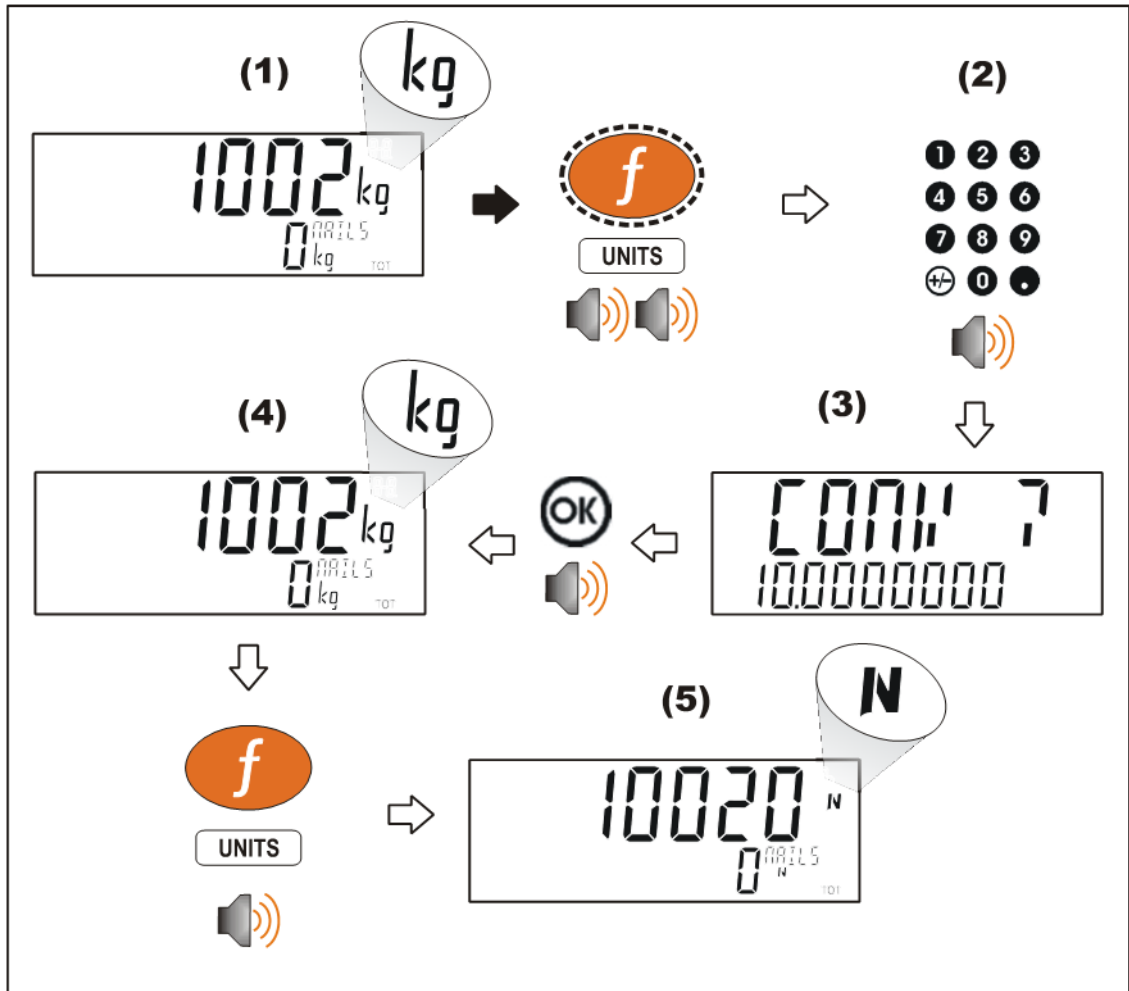

### 12.2.8. HOLD

A hold key performs a manual hold. Pressing the hold key again will cancel the hold.

#### ◆ Hold

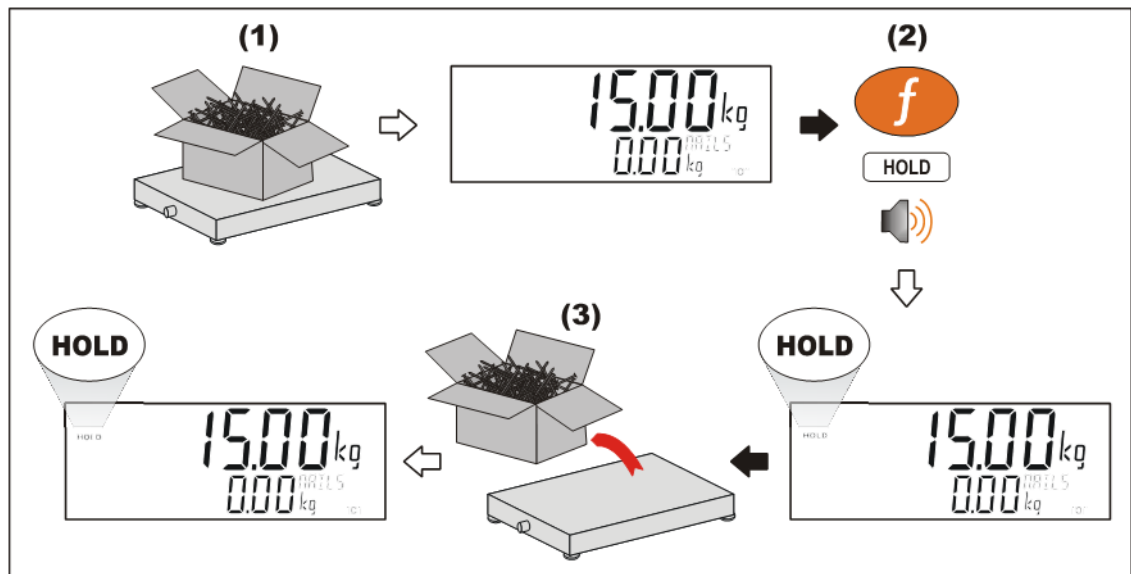

#### ◆ Release

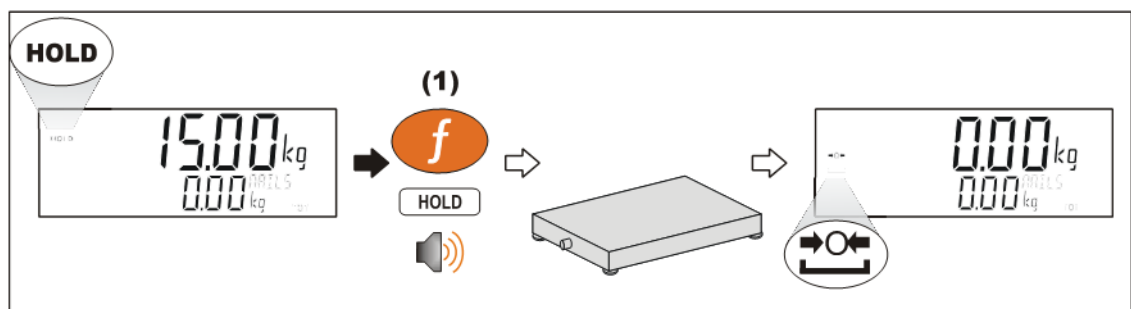

12.2.9. PEAK HOLD

The peak hold key implements a peak hold where the largest absolute weight, either positive or negative is stored and displayed.

◆ Short press

A short press will switch the peak hold display on and off.

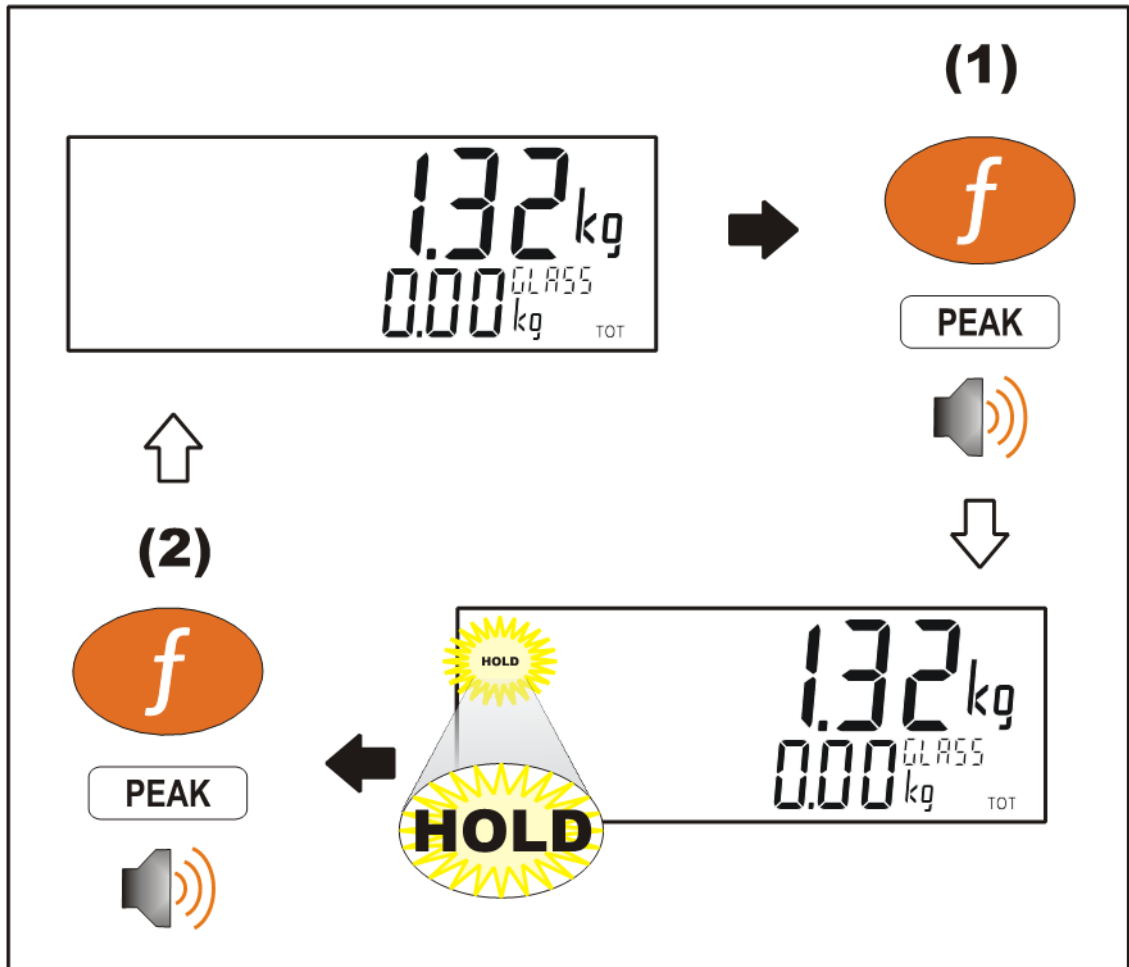

◆ Long press

A long press will clear the current peak values.

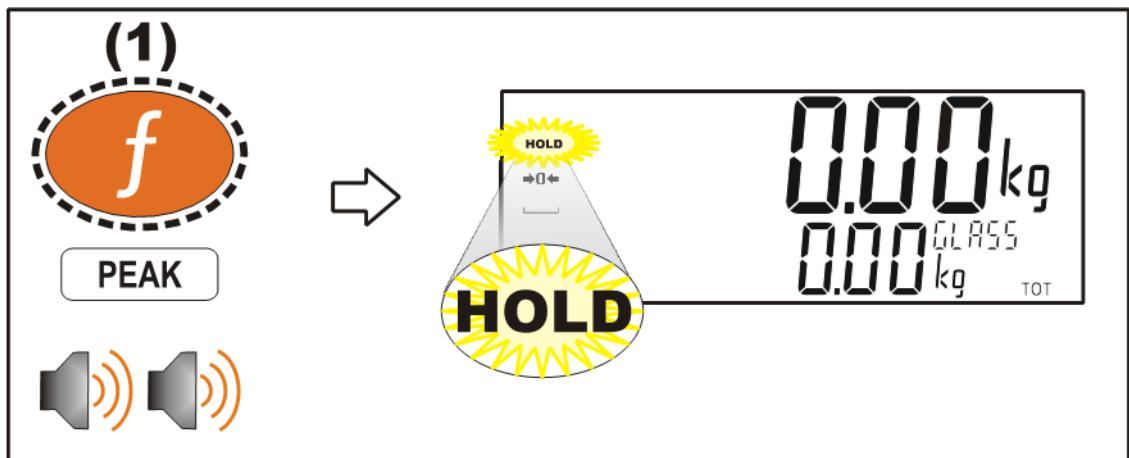

## ◆ The process

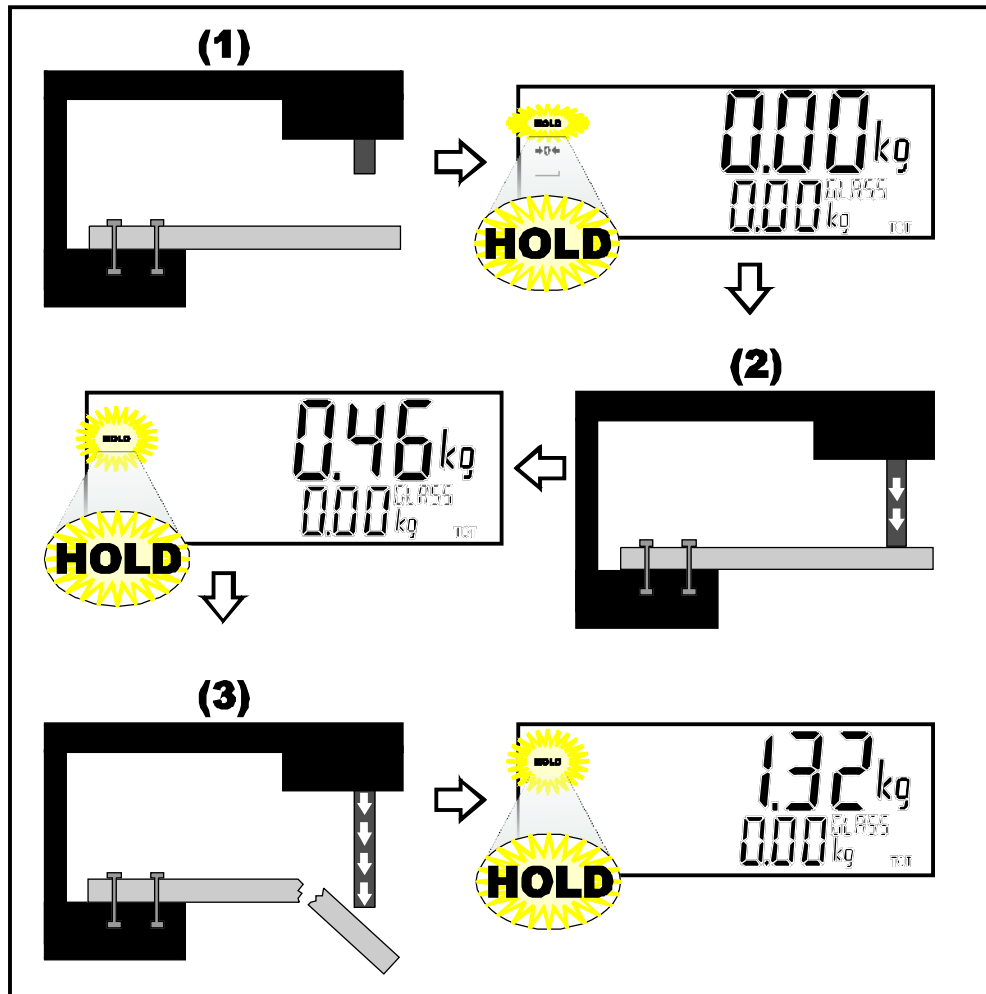

### 12.2.10. PRD.SEL

A short press of the product select button will cycle the total display (for the current product) through the available totals information. A long press allows the current product to be selected by number rather than name.

#### ◆ Short press

Cycles the display of totals information.

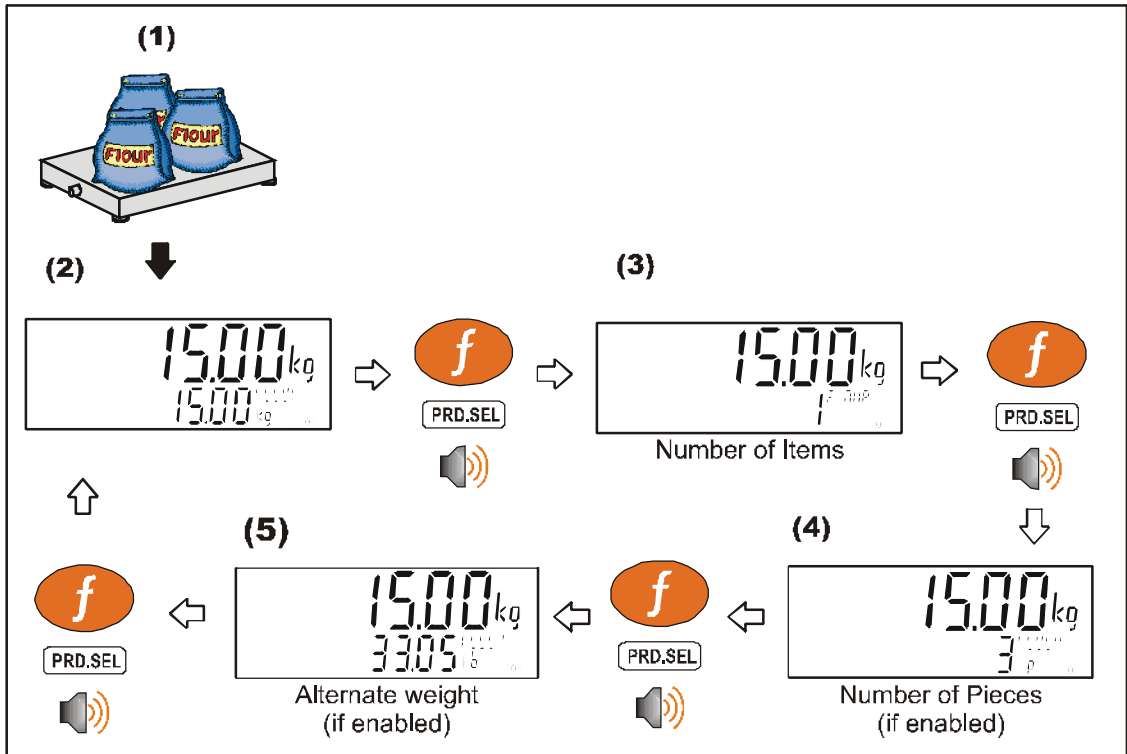

#### ◆ Long press

Select product by number.

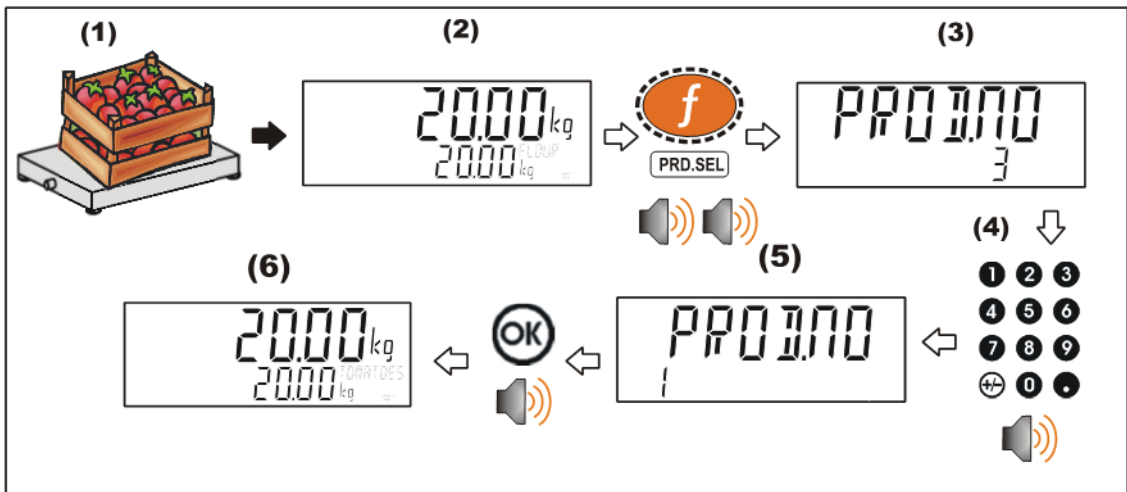

### 12.2.11. HI.RES

A short press of the high resolution button will enable or disable high resolution mode. If the instrument is in trade mode the high resolution mode will be restored to its original state after five seconds.

#### ◆ Short press – Industrial Mode

Display high resolution reading, until function key pressed again.

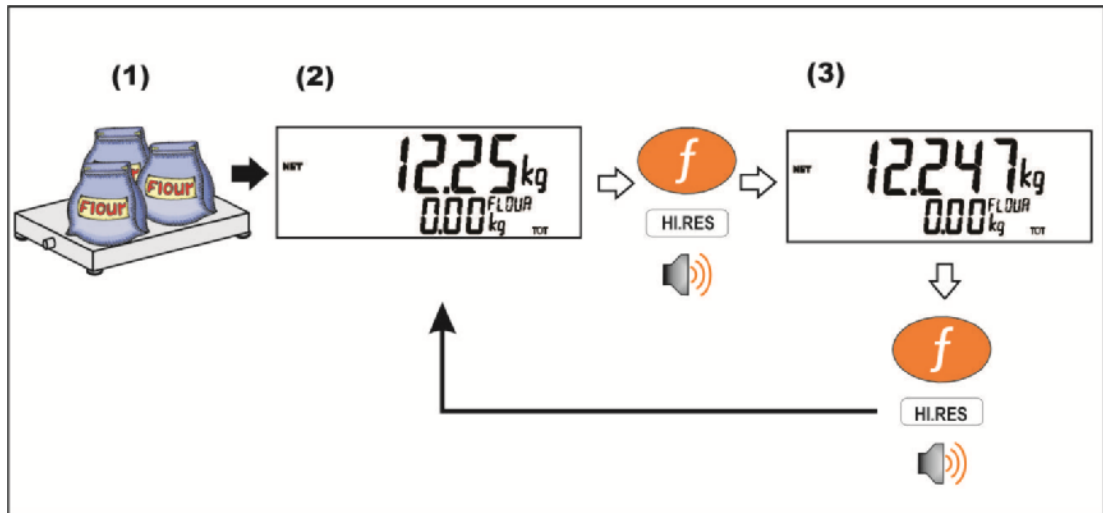

#### ◆ Short press – Trade Mode

Display high resolution reading for five (5) seconds, then return to original state.

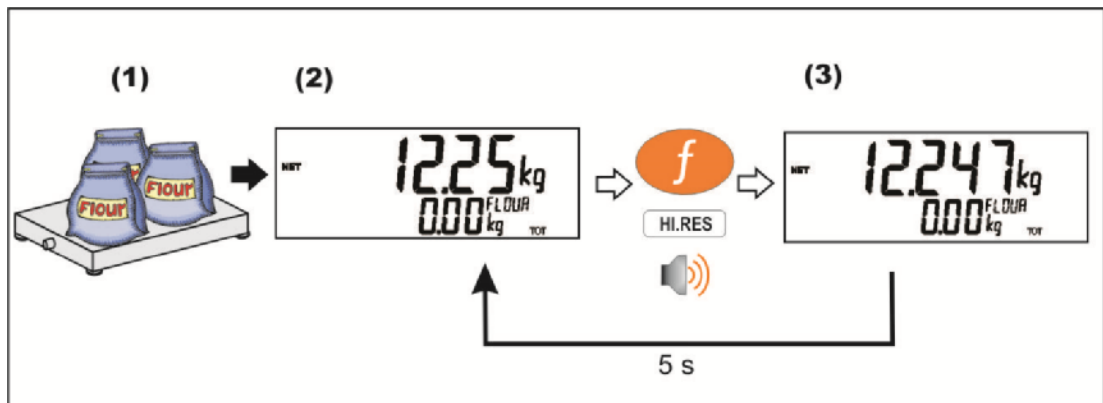

12.2.12. SC.EXIT

A short press of the scale exit button will trigger the scale exit setpoint if the weight is outside of the zero band.

12.2.13. SEMI.P.T

A short press of the semi-auto preset tare button will set the preset tare to the current gross weight.

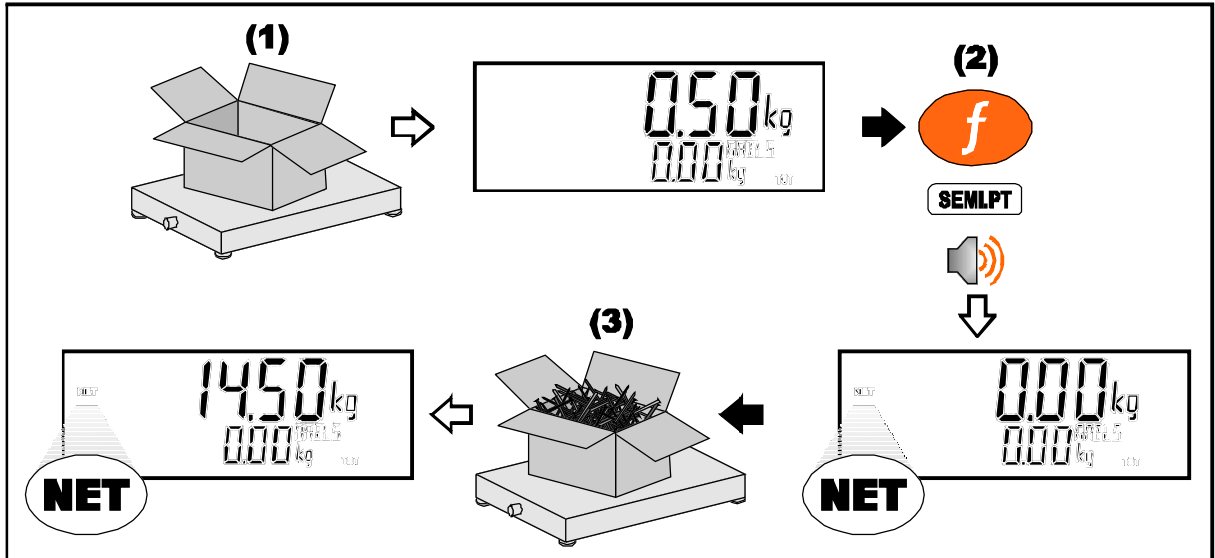

12.2.14. A.TARE

A short press of the auto tare button will enable or disable the auto tare feature, a capital A will be seen at the top left of the display when auto tare is enabled.

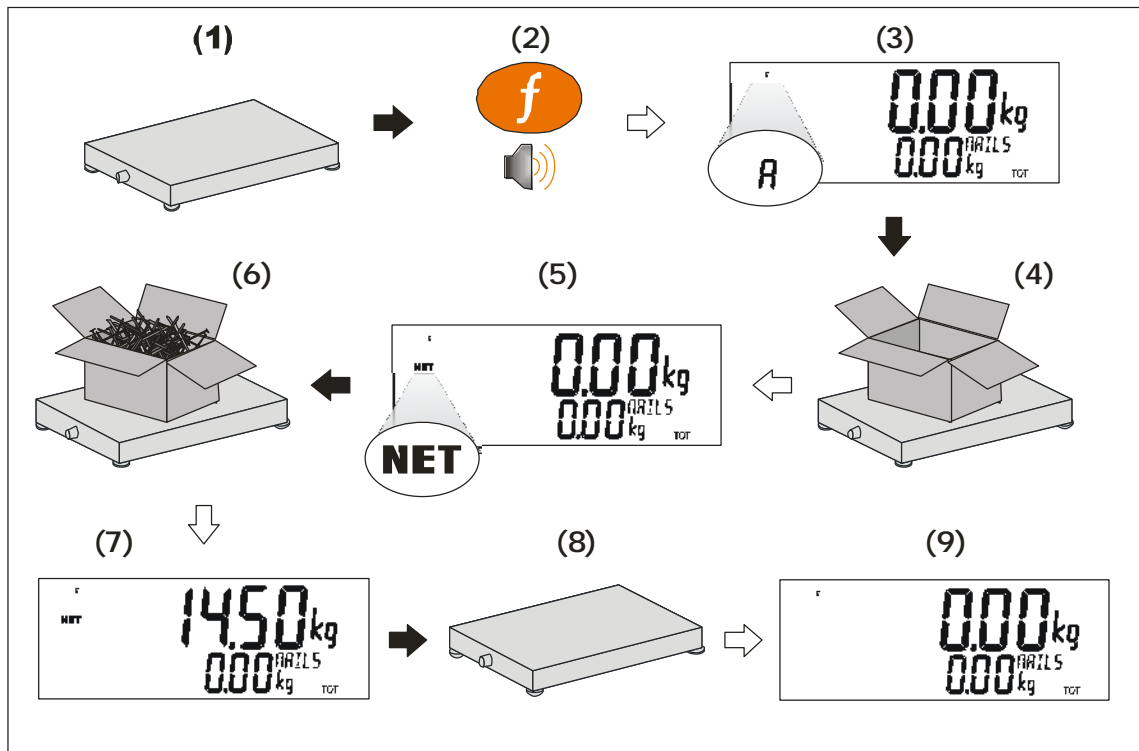

## 13. Setpoints

### 13.1. Overview

The K401 and K402 software supports up to 8 separate set points. Each set point is independently configured for a particular function and can be associated with a particular Output Driver. The set point can be configured to flash the instrument display or sound a buzzer as well as driving a physical output.

A set point target is set by the operator using the Target Key on the front panel or via Viewer using the Operator Menu. Refer to 5.2.12 Target page 36 for button operation.

The SCOPE setting for a set point defines if the target is global or can be set for each product.

### 13.2. Outputs

The instrument supports 32 input/output control points. The application software uses these control points to decide what the control functions are and the accessory modules respond according to their specific hardware.

Setpointing requires the use of outputs so it is important to select IO control points that have associated hardware output drivers that suit your application.

### 13.3. Common Settings

There are a number of settings that are common to all setpoint types. These are as follows:

- **OUTPUT:** Select which IO control point to use. Options are NONE, IO1..IO32. NONE is useful if the setpoint is only being used trigger an alarm.
- **LOGIC:** This setting determines whether the output is normally on or normally off. Logic HIGH means the output follows the activity of the setpoint and is on when the setpoint conditions are met. Logic LOW reverses the operation of the output.

For example: Consider a Center-of-Zero status setpoint. This type of setpoint is active when the Centre-of-Zero annunciator is lit. With logic HIGH an output would turn on whenever the Centre-of-Zero annunciator was lit. With logic LOW the output would turn off when the Centre-of-Zero annunciator is lit and remain on otherwise.

Note that the outputs revert to the off state when the instrument SETUP menus are active.

- **ALARM:** Select what alarm response is triggered when the setpoint is active. SINGLE sounds a single beep every two seconds, DOUBLE sounds a double beep every two seconds and FLASH flashes the instrument display. Note that the Alarm conditions are not influenced by the LOGIC setting, i.e. they follow the activity of the setpoint regardless of the physical state of the output.
- **NAME:** Name the setpoint. This will be shown when editing targets for OVER or UNDER type setpoints.

### 13.4. Weigh in (OVER) Setpoints and Weigh Out (UNDER) Setpoints

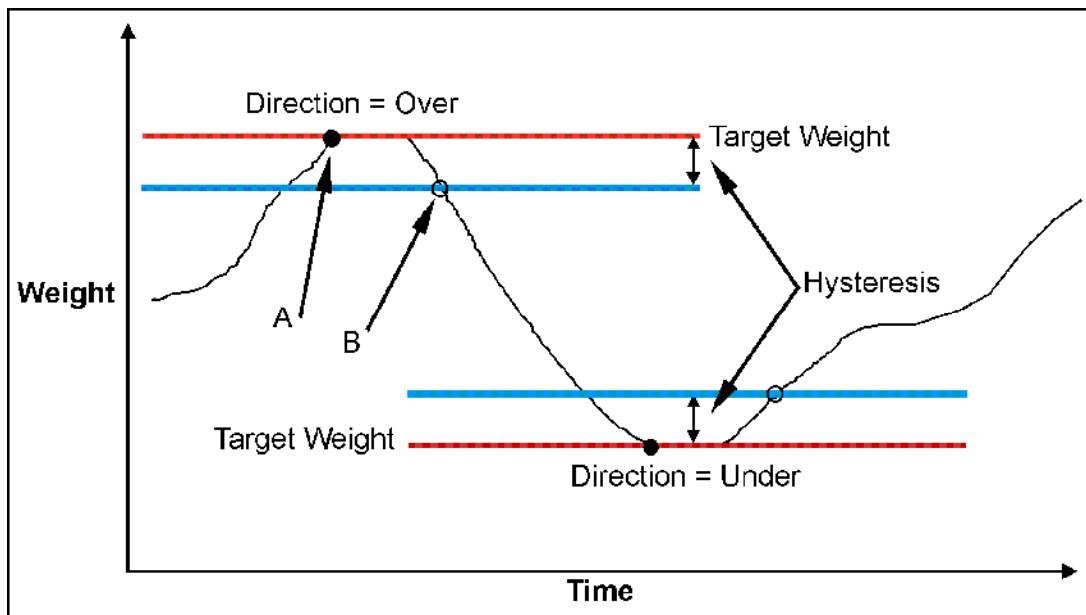

LOGIC	Point A	Point B
HIGH	ON	OFF
LOW	OFF	ON

Figure 13: OVER versus UNDER setpoints.

#### 13.4.1. Additional Settings

In addition to the common settings the following settings control the operation of the OVER and UNDER setpoints

- **SOURCE:** Select the weight source for the setpoint to use.

Options are:

- GROSS uses gross weight only
- NET uses net weight only
- 'GR or NT' uses either gross or net depending on which is currently displayed.
- ALT.GR uses alternate gross weight only
- ALT.NET uses alternate net weight only
- ALT.G or N uses either alternate gross of alternate net depending on which is currently displayed.
- PIECE uses gross or net piece count depending on which is currently displayed.
- REG: uses a register value.
- **SCOPE:** GLOBAL means that the same targets are used for every product. PROD lets each product have its own target values for the setpoint.

- **Hysteresis (HYS):** This setting determines the change in weight required for an active setpoint to become inactive again. A value of zero still leaves 0.5 graduations of hysteresis.
- **REG:** If the source is set to register (REG) then this setting is used to set the register to use. The register must be a number or weight value.

### 13.5. Status Based Setpoint Types

The following setpoint types are all based on the status of the instrument.

- **NONE:** Setpoint is always inactive.
- **ON:** Setpoint is always active. This type of setpoint is useful to show that the instrument is running.
- **Centre of Zero (COZ):** Setpoint is active when COZ annunciator is lit.
- **ZERO:** Setpoint is active when the weight is within the Zero Band setting.
  - **SOURCE:** The ZERO setpoint also has a SOURCE setting to determine if the zero condition is based on the gross or net reading. The GR.or.NT option uses the currently selected weight (gross or net).
- **NET:** Setpoint is active when the NET annunciator is lit.
- **MOTION:** Setpoint is active when the MOTION annunciator is lit.
- **ERROR:** Setpoint is active when the instrument detects any error condition signified by the display of Exxxxx on the primary display.
- **BUZZER:** Setpoint is active when the buzzer beeps.

### 13.6. Logic Setpoint Types

The following setpoint types are all based on the status of the inputs and the mask.

- **AND (LGC.AND):** Setpoint is active when all inputs in the mask are on.
- **OR (LGC.OR):** Setpoint is active when any inputs in the mask are on.
- **XOR (LGC.XOR):** Setpoint is active when only one input in the mask is on.

**SOURCE:** Select the source for the setpoint to use.

Options are:

- **IO** use the external IO
- **Status** use the instrument status
- **SETP** use the setpoint status
- **REG** use a register value

**REG:** If the source is set to register (REG) then this setting is used to set the register to use. The register must be a number or weight value. The decimal value of the register address should be used.

**MASK:** A 32 bit number that is use to match against the selected source. If the source is set to IO then IO1 is the least significant (first) bit and IO32 is the most significant (32<sup>nd</sup>) bit. If the source is set to setpoint (SETP) then setpoint 1 is the least significant (first) bit and setpoint 8 is the eighth bit, see second table below. The instrument status is broken down in the following table. This number should be entered as a decimal value.

Status info	Bit
Unused	Bits 19-32
Weight not held	18
Weight held	17
No errors	16
Overload	15
Underload	14
Error	13
Preset tare not active	12
Preset tare active	11
High range	10
Low range	9
Stable	8
Motion	7
Not centre-of-zero	6
Centre-of-zero	5
Not Zero	4
Zero	3
Gross	2
Net	1

SETP info	Bit
Unused	Bits 16-32
Not setpoint 8	16
Not setpoint 7	15
Not setpoint 6	14
Not setpoint 5	13
Not setpoint 4	12
Not setpoint 3	11
Not setpoint 2	10
Not setpoint 1	9
Setpoint 8	8
Setpoint 7	7
Setpoint 6	6
Setpoint 5	5
Setpoint 4	4
Setpoint 3	3
Setpoint 2	2
Setpoint 1	1

**DLY.ON:** delay before setpoint becomes active.

**HLD.OFF:** delay before setpoint becomes inactive.

### 13.7. Scale Entry/Exit Setpoint Types

The following setpoint types are all based on the status of the indicator.

- **Scale Ready (SC.REDY):** Setpoint is active when in the zero band and stable for longer than the time set in RDY.TIM.
- **Scale Exit (SC.EXIT):** Setpoint is active when outside of the zero band and either a print has occurred or the scale exit (SC.EXIT) special function has been triggered.

**Ready Time (RDY.TIM):** Time in seconds that the scale must be stable in the zero band before the scale is ready.

## 14. Analogue Output

### 14.1. Overview

The indicator supports a single analogue output used for analogue weight transmission. Setting up a system is a two stage process:

- First install the analogue output hardware and configure, calibrate and test the accessory module using the options in the H.WARE:ANL.HW menu.
- Second, configure the parameters of the information to be sent to the analogue output from the ANL.OUT menu.

### 14.2. Configuration of Hardware

#### 14.2.1. Configuration

**TYPE:** Set the TYPE to VOLTAGE (0..10V) or CURRENT (4..20mA). The analogue accessory will light an LED to indicate which output type is active.

**CLIP:** The CLIP setting determines if the analogue output is allowed to extend past the nominal limits. If CLIP is ON, the output will not go below 0V or above 10V for voltage outputs. For current output the limits are 4mA and 20mA. If CLIP is OFF the voltage can extend an extra 0.5 Volts or so past the limits and the current can extend from 0mA to 24mA.

#### 14.2.2. Calibration

Calibrate the lower and upper values of the analogue output using the CAL.LO and CAL.HI functions. Use the UP and DOWN arrows to adjust the output to the external system.

#### 14.2.3. Testing

The analogue output can be driven to any value using the FRC.OUT function. Use the UP and DOWN arrows to move the output up and down to test that the values shown on the instrument display match the readings taken externally.

### 14.3. Analogue Weight Transmission

**ABS (Absolute):** This setting allows negative weight readings to be treated as positive values for the purposes of the analogue output transmission. This is especially useful when transmitting negative net readings in WEIGH-OUT applications.

**SOURCE:** Use the SOURCE setting to determine what weight readings are to be sent. Options include gross weight always (GROSS), net weight always (NET) or gross or net readings depending on which is selected and currently displayed on the main display.

**WGT.LO (Weight Low)** and **WGT.HI (Weight High)** settings specify the weight range that corresponds to the analogue output range. For example, it is possible to set the instrument up to send a 0..10V signal between 10.0 kg and 20.0kg even though the scale is calibrated to measure weight from 0.0kg to 50.0kg. This effectively increases the resolution of the analogue output over the weight range of interest.

## 15. Appendix 1: Dimensions

Weight Indicator		Dimensions in mm (1 inch = 25.4 mm)	
<b>3D View</b> 	<b>Front View</b> 	<b>Side View</b> 	<b>Back View</b> 
Weight Indicator (With Rear Enclosure)		Dimensions in mm (1 inch = 25.4 mm)	
<b>3D View</b> 	<b>Back View</b> 	<b>Side View With Boot and Stand</b> 	<b>Side View</b> 

Table 7: Dimensions



## 15.1. Legal Sealing Details

There are several methods of legally sealing the instrument. The method chosen will depend on local regulations.

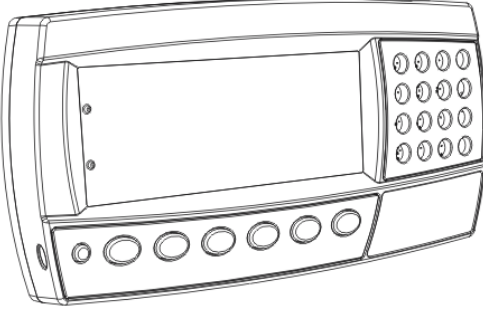
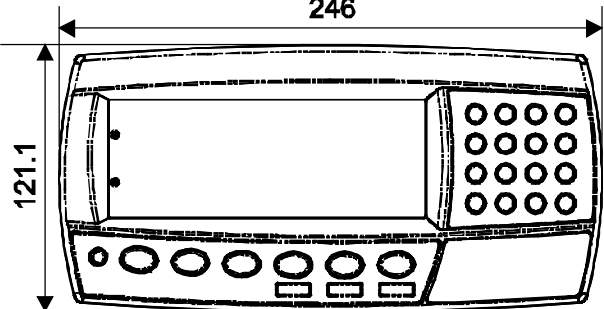
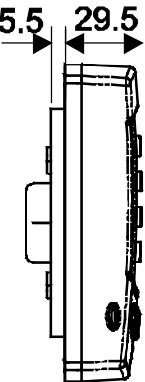
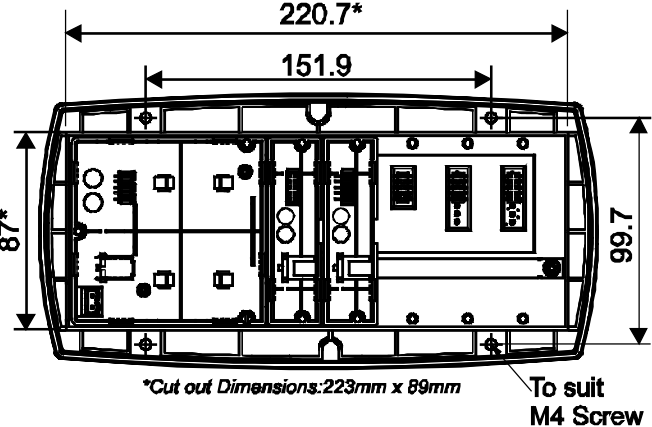
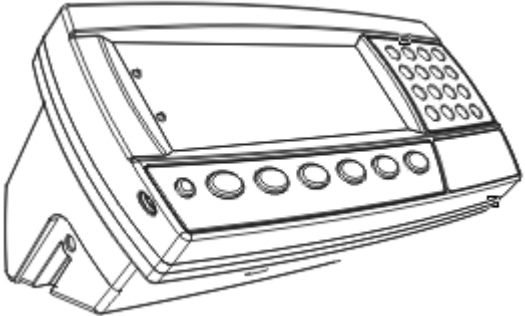
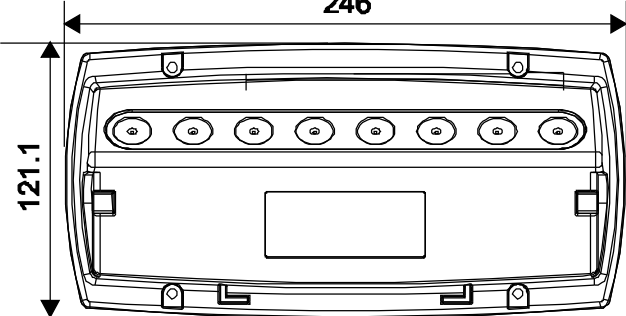
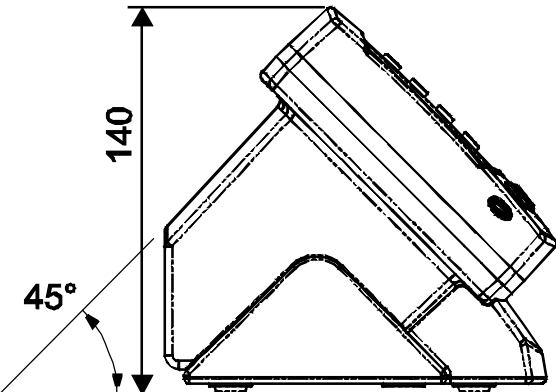
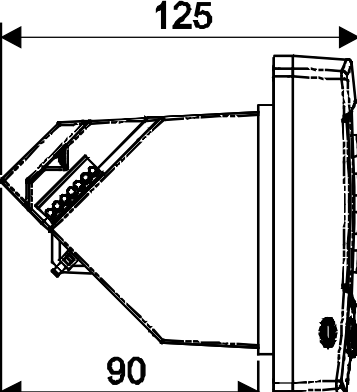
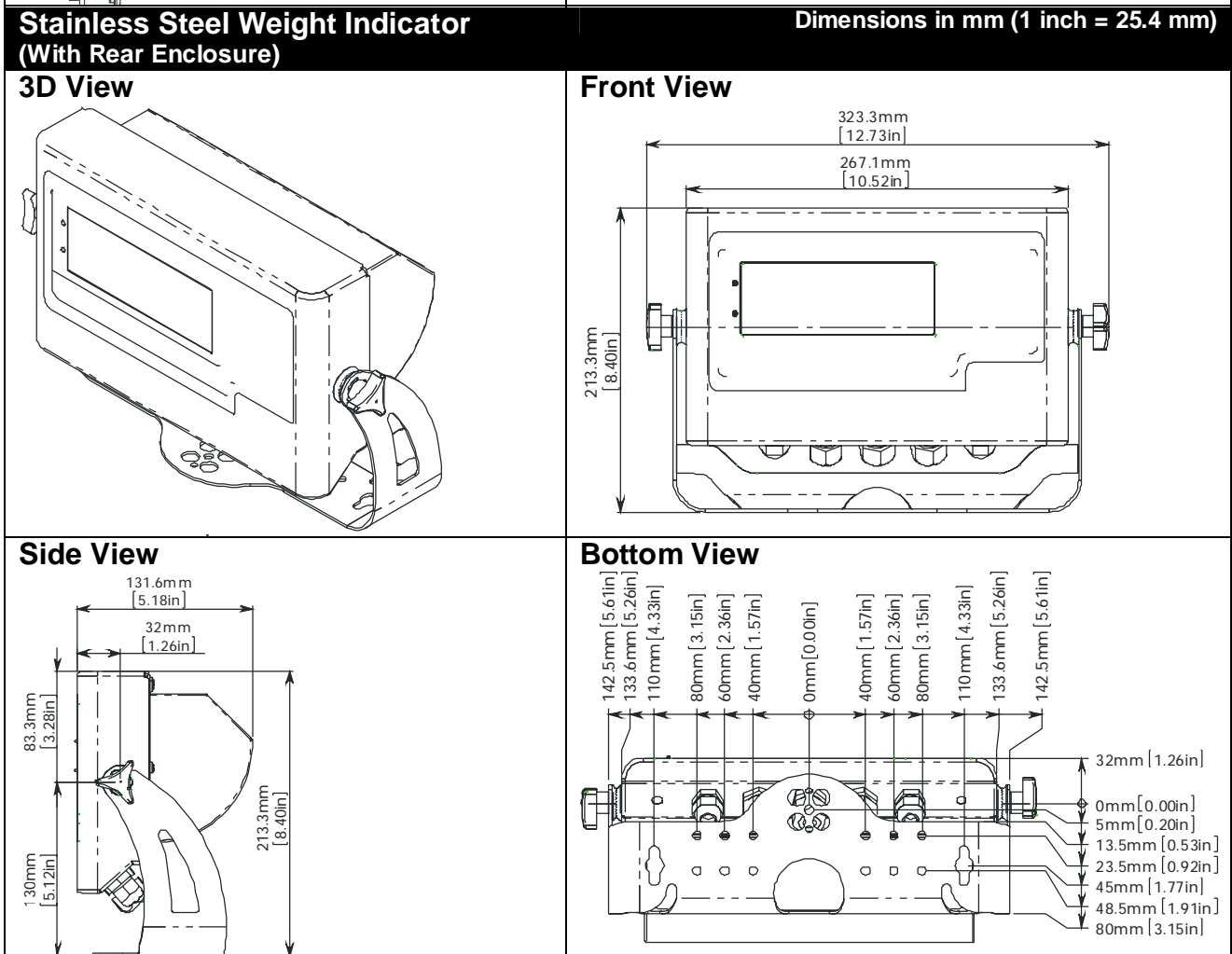
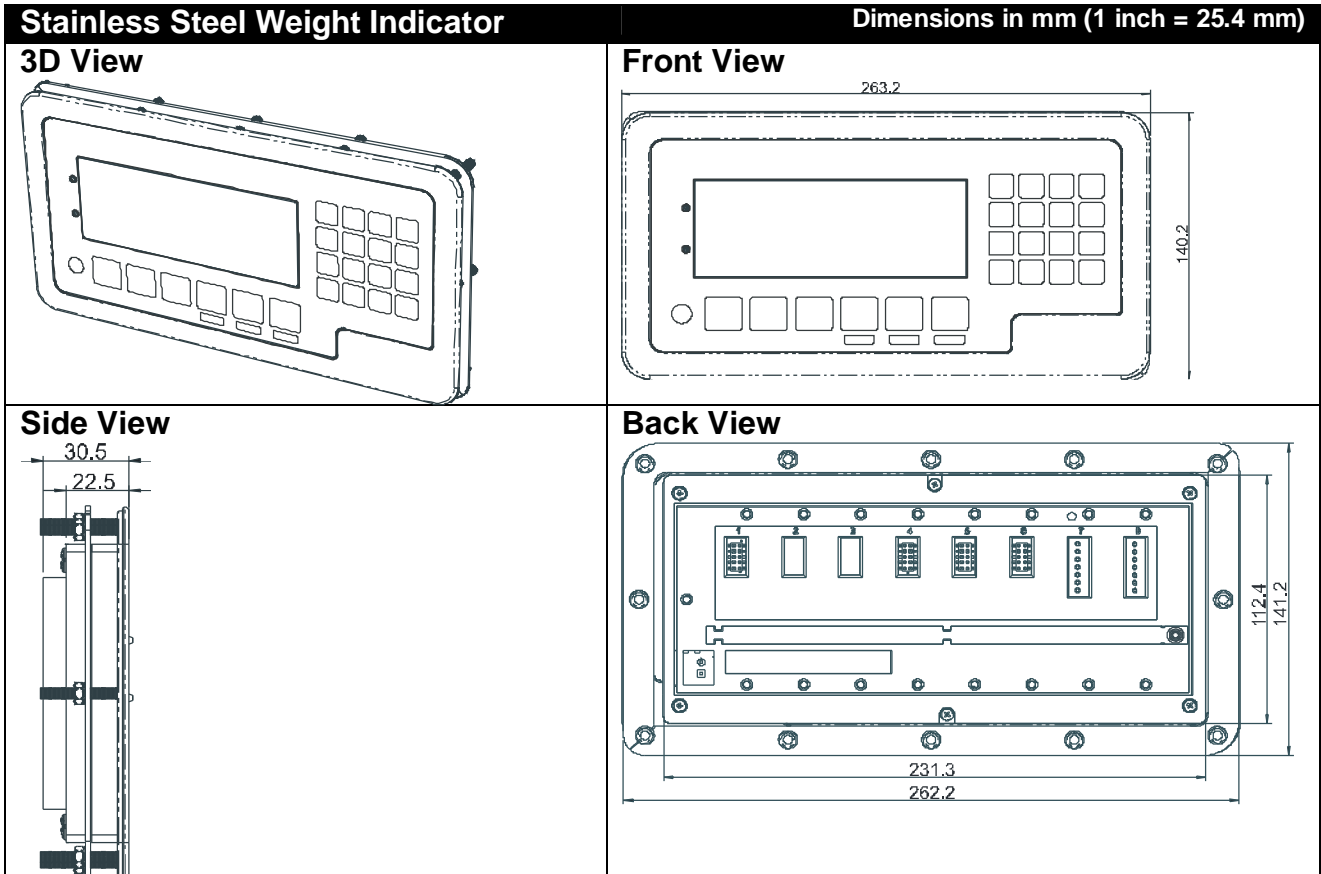
### 15.1.1. Trade Label

A trade label showing scale and instrument information is usually required. This can be placed on the front of the instrument:

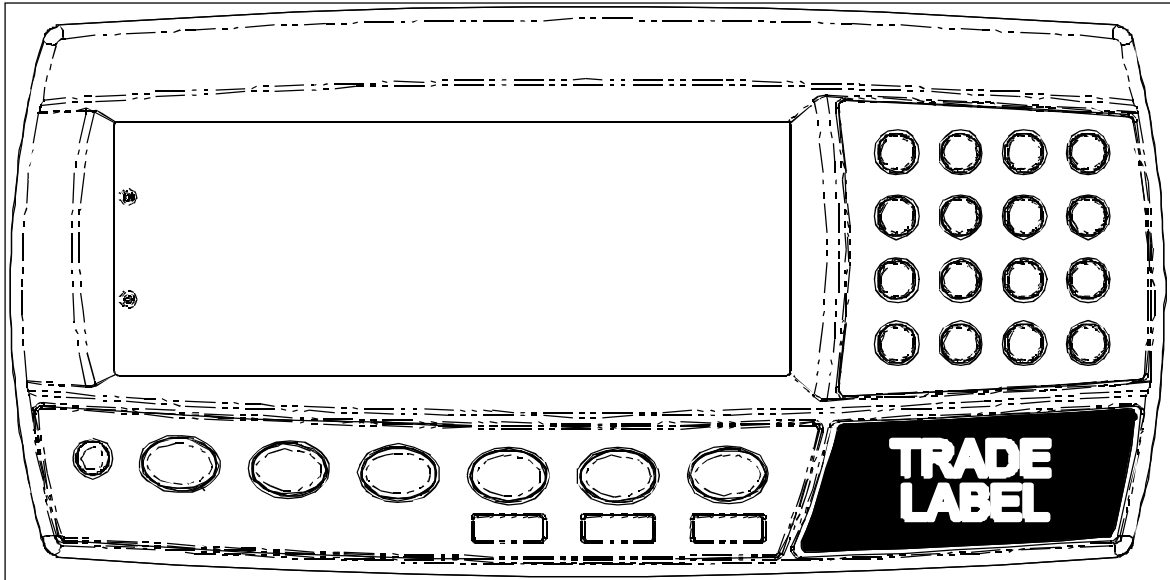

Figure 14: Trade label position.

### 15.1.2. Lead Seals

There are 2 methods of sealing the instrument with lead and wire seals:

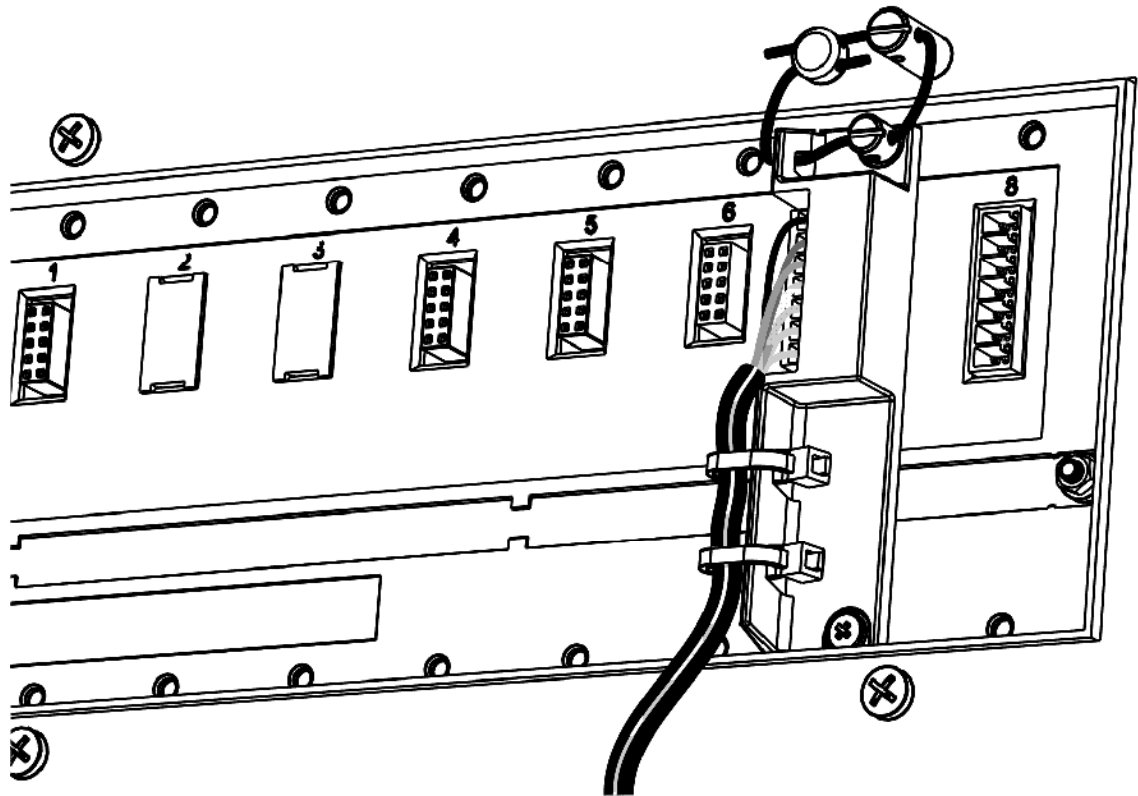

Figure 15: Lead seal on rear of instrument.

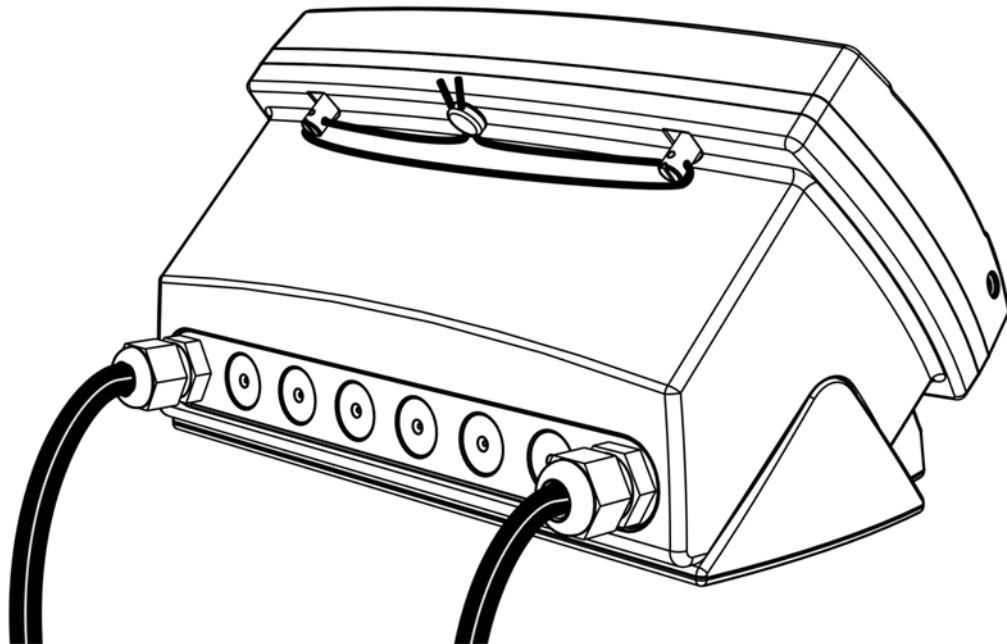

Figure 16: Lead seal on boot.

### 15.1.3. Destructible Sticker Seals

There are 2 methods of sealing with destructible stickers:

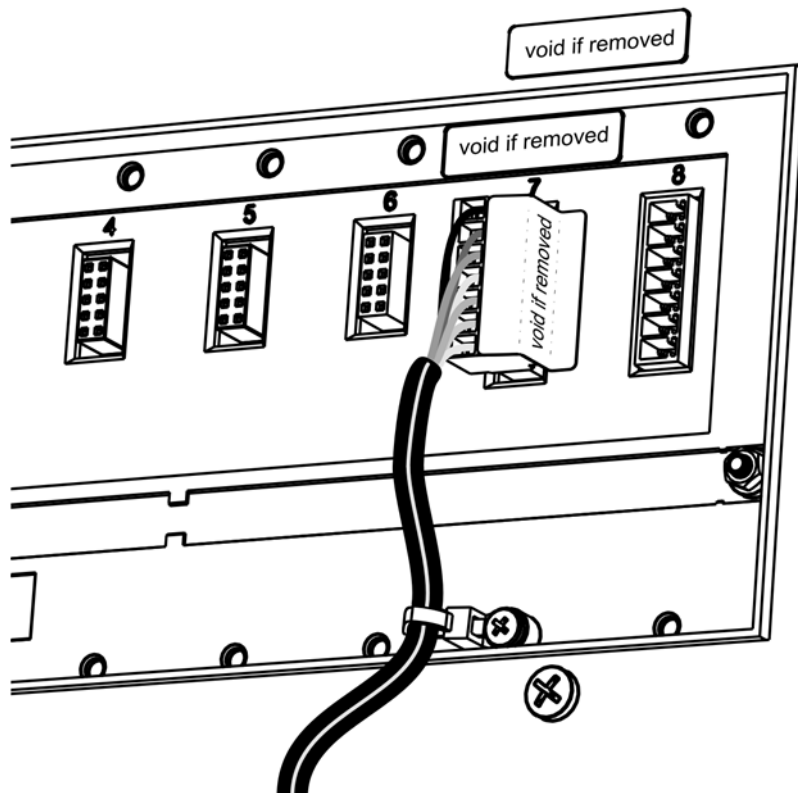

Figure 17: Destructible sticker seal on rear of instrument.

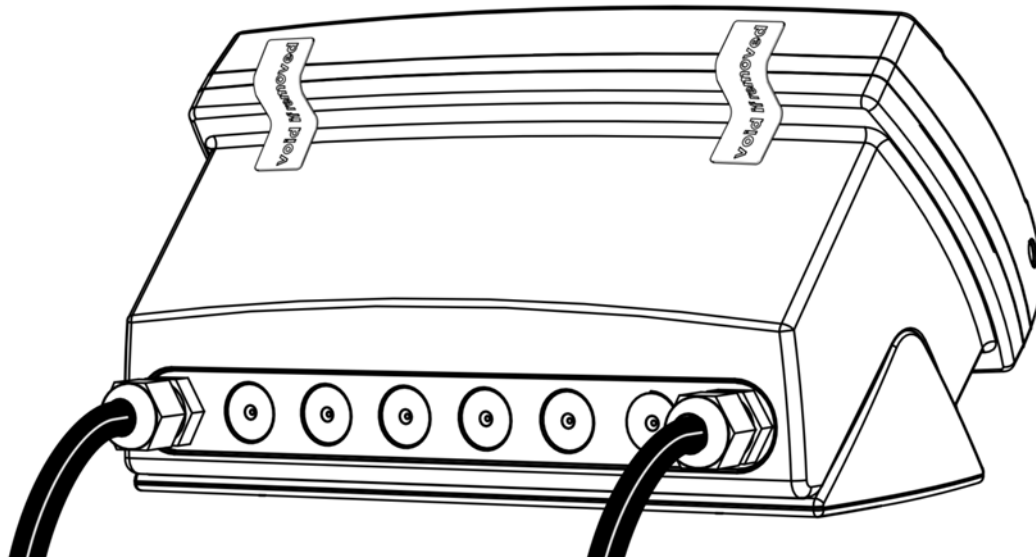

Figure 18: Destructible sticker seal on boot.

### 15.1.4. Electronic Seal

The value of the calibration counter should be written on the scale certification/sealing sticker. See page 40 for as description of the calibration counter.

## 16. Appendix 2: Print and Automatic Transmission Tokens

### 16.1. ASCII codes

Code	Char	Code	Ch	Code	Ch	Code	Ch	Code	Ch
000 (0)	NULL	026 (1A <sub>H</sub> )	SUB	052 (34 <sub>H</sub> )	'4'	078 (4E <sub>H</sub> )	'N'	104 (68 <sub>H</sub> )	'h'
001 (01 <sub>H</sub> )	SOH	027 (1B <sub>H</sub> )	ESC	053 (35 <sub>H</sub> )	'5'	079(4F <sub>H</sub> )	'O'	105 (69 <sub>H</sub> )	'i'
002 (02 <sub>H</sub> )	STX	028 (1C <sub>H</sub> )	FS	054 (36 <sub>H</sub> )	'6'	080 (50 <sub>H</sub> )	'P'	106 (6A <sub>H</sub> )	'j'
003 (03 <sub>H</sub> )	ETX	029 (1D <sub>H</sub> )	GS	055 (37 <sub>H</sub> )	'7'	081 (51 <sub>H</sub> )	'Q'	107 (6B <sub>H</sub> )	'k'
004 (04 <sub>H</sub> )	EOT	030 (1E <sub>H</sub> )	RS	056 (38 <sub>H</sub> )	'8'	082 (52 <sub>H</sub> )	'R'	108 (6C <sub>H</sub> )	'l'
005 (05 <sub>H</sub> )	ENQ	031 (1F <sub>H</sub> )	US	057 (39 <sub>H</sub> )	'9'	083 (53 <sub>H</sub> )	'S'	109 (6D <sub>H</sub> )	'm'
006 (06 <sub>H</sub> )	ACK	032 (20 <sub>H</sub> )	' '	058 (3A <sub>H</sub> )	':'	084 (54 <sub>H</sub> )	'T'	110 (6E <sub>H</sub> )	'n'
007 (07 <sub>H</sub> )	BEL	033 (21 <sub>H</sub> )	'!	059 (3B <sub>H</sub> )	','	085 (55 <sub>H</sub> )	'U'	111 (6F <sub>H</sub> )	'o'
008 (08 <sub>H</sub> )	BS	034 (22 <sub>H</sub> )	""	060 (3C <sub>H</sub> )	'<'	086 (56 <sub>H</sub> )	'V'	112 (70 <sub>H</sub> )	'p'
009 (09 <sub>H</sub> )	HT	035 (23 <sub>H</sub> )	'#'	061 (3D <sub>H</sub> )	'='	087 (57 <sub>H</sub> )	'W'	113 (71 <sub>H</sub> )	'q'
010 (0A <sub>H</sub> )	LF	036 (24 <sub>H</sub> )	'\$'	062 (3E <sub>H</sub> )	'>'	088 (58 <sub>H</sub> )	'X'	114 (72 <sub>H</sub> )	'r'
011 (0B <sub>H</sub> )	VT	037 (25 <sub>H</sub> )	'%'	063 (3F <sub>H</sub> )	'?'	089 (59 <sub>H</sub> )	'Y'	115 (73 <sub>H</sub> )	's'
012 (0C <sub>H</sub> )	FF	038 (26 <sub>H</sub> )	'&'	064 (40 <sub>H</sub> )	'@'	090 (5A <sub>H</sub> )	'Z'	116 (74 <sub>H</sub> )	't'
013 (0D <sub>H</sub> )	CR	039 (27 <sub>H</sub> )	""	065 (41 <sub>H</sub> )	'A'	091 (5B <sub>H</sub> )	'['	117 (75 <sub>H</sub> )	'u'
014 (0E <sub>H</sub> )	SO	040 (28 <sub>H</sub> )	'('	066 (42 <sub>H</sub> )	'B'	092 (5C <sub>H</sub> )	'\'	118 (76 <sub>H</sub> )	'v'
015 (0F <sub>H</sub> )	SI	041 (29 <sub>H</sub> )	')'	067 (43 <sub>H</sub> )	'C'	093 (5D <sub>H</sub> )	']'	119 (77 <sub>H</sub> )	'w'
016 (10 <sub>H</sub> )	DLE	042 (2A <sub>H</sub> )	'*'	068 (44 <sub>H</sub> )	'D'	094 (5E <sub>H</sub> )	'^'	120 (78 <sub>H</sub> )	'x'
017 (11 <sub>H</sub> )	DC1	043 (2B <sub>H</sub> )	'+'	069 (45 <sub>H</sub> )	'E'	095 (5F <sub>H</sub> )	'_'	121 (79 <sub>H</sub> )	'y'
018 (12 <sub>H</sub> )	DC2	044 (2C <sub>H</sub> )	','	070 (46 <sub>H</sub> )	'F'	096 (60 <sub>H</sub> )	'`'	122 (7A <sub>H</sub> )	'z'
019 (13 <sub>H</sub> )	DC3	045 (2D <sub>H</sub> )	'-'	071 (47 <sub>H</sub> )	'G'	097 (61 <sub>H</sub> )	'a'	123 (7B <sub>H</sub> )	'{'
020 (14 <sub>H</sub> )	DC4	046 (2E <sub>H</sub> )	'.'	072 (48 <sub>H</sub> )	'H'	098 (62 <sub>H</sub> )	'b'	124 (7C <sub>H</sub> )	' '
021 (15 <sub>H</sub> )	NAK	047 (2F <sub>H</sub> )	','	073 (49 <sub>H</sub> )	'I'	099 (63 <sub>H</sub> )	'c'	125 (7D <sub>H</sub> )	'}'
022 (16 <sub>H</sub> )	SYN	048 (30 <sub>H</sub> )	'0'	074 (4A <sub>H</sub> )	'J'	100 (64 <sub>H</sub> )	'd'	126 (7E <sub>H</sub> )	'~'
023 (17 <sub>H</sub> )	ETB	049 (31 <sub>H</sub> )	'1'	075 (4B <sub>H</sub> )	'K'	101 (65 <sub>H</sub> )	'e'	127 (7F <sub>H</sub> )	DEL
024 (18 <sub>H</sub> )	CAN	050 (32 <sub>H</sub> )	'2'	076 (4C <sub>H</sub> )	'L'	102 (66 <sub>H</sub> )	'f'		
025 (19 <sub>H</sub> )	EM	051 (33 <sub>H</sub> )	'3'	077 (4D <sub>H</sub> )	'M'	103 (67 <sub>H</sub> )	'g'		

**Table 8: ASCII Table**

(\*) Use ASCII 128 to implement a literal NULL character in a custom string. ASCII 0 is used to define the end of the string.

### 16.2. Use of Characters in the Extended ASCII table

To use characters in the extended ASCII table, 026 (1A<sub>H</sub>) should be used - it will allow the next character in a custom print string to be sent directly.

Example:

\1A\84 would be ä

### 16.3. Tokens

Tokens are special ASCII characters outside the normal printing range. These characters are used to specify where instrument data fields like 'Current Weight' are to be inserted into custom format strings.

#### 16.3.1. Non-paged generic tokens

Code	Token
128 (80 <sub>H</sub> )	ASCII NULL (send an ASCII 00H character)
191 (BF <sub>H</sub> )	Date
192 (C0 <sub>H</sub> )	Time (24H format)
193 (C1 <sub>H</sub> )	Newline
194 (C2 <sub>H</sub> )	Left spaces
195 (C3 <sub>H</sub> )	Top blank lines
196 (C4 <sub>H</sub> )	Bottom blank lines
197 (C5 <sub>H</sub> )	Unique consecutive print ID
198 (C6 <sub>H</sub> )	Header
199 (C7 <sub>H</sub> )	Footer
200 (C8 <sub>H</sub> )	Page end string
201 (C9 <sub>H</sub> )	User String Data 1
202 (CA <sub>H</sub> )	User String Data 2
203 (CB <sub>H</sub> )	User String Data 3
204 (CC <sub>H</sub> )	User String Data 4
205 (CD <sub>H</sub> )	User String Data 5
206 (CE <sub>H</sub> )	User String Name 1
207 (CF <sub>H</sub> )	User String Name 2
208 (D0 <sub>H</sub> )	User String Name 3
209 (D1 <sub>H</sub> )	User String Name 4
210 (D2 <sub>H</sub> )	User String Name 5
211 (D3 <sub>H</sub> )	Time (12H format)
213 (D5 <sub>H</sub> )	Settable consecutive print ID
214 (D6 <sub>H</sub> )	Reset to 1 the settable consecutive print ID

**Table 9: Print tokens: generic**

#### 16.3.2. Page tokens

As there is too much data to represent as individual tokens the tokens are divided up into pages. A page token is used to define the page for all subsequent tokens.

Code	Token
190 (BE <sub>H</sub> )	Page 0: Current Weight
189 (BD <sub>H</sub> )	Page 1: Held Weight
188 (BC <sub>H</sub> )	Page 2: Held or Current Weight
187 (BB <sub>H</sub> )	Page 3: Traceable Weight
186 (BA <sub>H</sub> )	Page 4: Current Product
185 (B9 <sub>H</sub> )	Page 5: Session Total
184 (B8 <sub>H</sub> )	Page 6: Grand Total
183 (B7 <sub>H</sub> )	Page 7: Register Data
182 (B6 <sub>H</sub> )	Page 8: Miscellaneous weight data

**Table 10: Print tokens: pages**

**16.3.3. Page 0, 1, 2, 3, 7 tokens: Weight Information**

These pages hold weight information. The same codes are used for each page.

Code	Token	
215 (D7 <sub>H</sub> )	Displayed reading (gross or net)	
216 (D8 <sub>H</sub> )	Gross reading	
217 (D9 <sub>H</sub> )	Net reading	
218 (DA <sub>H</sub> )	Piece reading	
219 (DB <sub>H</sub> )	Alternative displayed reading (gross or net)	
220 (DC <sub>H</sub> )	Alternative gross reading	
221 (DD <sub>H</sub> )	Alternative net reading	
222 (DE <sub>H</sub> )	mV/V value	
223 (DF <sub>H</sub> )	Absolute gross peak reading	
224 (E0 <sub>H</sub> )	Preset tare value	
225 (E1 <sub>H</sub> )	Tare value (tare or preset tare)	
226 (E2 <sub>H</sub> )	Tare label (T or PT)	
227 (E3 <sub>H</sub> )	Unit ID	page 0 only
	Tracable weight date	Page 3 only
	Register Header	Page 7 only
228 (E4 <sub>H</sub> )	Ticket end	page 0 only
	Tracable weight time	Page 3 only
	Register Footer	Page 7 only
229 (E5 <sub>H</sub> )	Status 0: <b>Error, Overload, Underload, Motion, Net, Gross</b> (Uses last weight sent)	page 0 only
230 (E6 <sub>H</sub> )	Status 1: <b>Error, Overload, Underload, Net, Gross</b> (Uses last weight sent)	page 0 only
231 (E7 <sub>H</sub> )	Status 2: <b>Motion</b> , ‘ ‘	page 0 only
232 (E8 <sub>H</sub> )	Status 3: <b>Centre of Zero</b> , ‘ ‘	page 0 only
233 (E9 <sub>H</sub> )	Status 4: <b>-</b> , <b>Range 1</b> , <b>Range 2</b> (Uses last weight sent)	page 0 only
234 (EA <sub>H</sub> )	Status 5: <b>C</b> , <b>Motion</b> , ‘ ‘	page 0 only
235 (EB <sub>H</sub> )	Status 6: <b>_N_ Net, _G_ Gross</b> (Uses last weight sent)	page 0 only
236 (EC <sub>H</sub> )	Status 7: <b>Error, Overload, Underload, Motion, Net, Gross</b> (Uses automatic transmission reading)	page 0 only
237 (ED <sub>H</sub> )	Automatic transmit reading	page 0 only
238 (EE <sub>H</sub> )	Automatic transmit start characters	page 0 only
239 (EF <sub>H</sub> )	Automatic transmit end characters	page 0 only
240 (F0 <sub>H</sub> )	Weight units	page 0 only
241 (F1 <sub>H</sub> )	Displayed string (primary display)	page 0 only
242 (F2 <sub>H</sub> )	Displayed unit (primary display)	page 0 only
243 (F3 <sub>H</sub> )	Auto Transmit FMT.REG header	page 0 only
244 (F4 <sub>H</sub> )	Auto Transmit FMT.REG weight	page 0 only
245 (F5 <sub>H</sub> )	Auto Transmit FMT.REG status	page 0 only
246 (F6 <sub>H</sub> )	Auto Transmit FMT.REG footer	page 0 only
247 (F7 <sub>H</sub> )	Alternative Tare value	page 0 only
248 (F8 <sub>H</sub> )	Status 8: <b>Overload, Underload, In range</b>	page 0 only
249 (F9 <sub>H</sub> )	Status 9: <b>Motion, Stable</b>	page 0 only
250 (FA <sub>H</sub> )	Status 10: <b>OL</b> over/underload, <b>US</b> unstable, <b>ST</b> stable	page 0 only
251 (FB <sub>H</sub> )	Status 11: <b>Gross, Net</b>	page 0 only
252 (FC <sub>H</sub> )	IO status	page 0 only
253 (FD <sub>H</sub> )	Setpoint status	page 0 only

**Table 11: Print tokens: weight information**

**16.3.4. Page 4, 5, 6 tokens: Product Information:**

These pages hold product information where:

<b>Code</b>	<b>Token</b>
215 (D7 <sub>H</sub> )	Product name
216 (D8 <sub>H</sub> )	Barcode
217 (D9 <sub>H</sub> )	Total weight
218 (DA <sub>H</sub> )	Total alternative weight
219 (DB <sub>H</sub> )	Total pieces
220 (DC <sub>H</sub> )	Number of adds
221 (DD <sub>H</sub> )	Total docket weight
222 (DE <sub>H</sub> )	Total docket alternative weight
223 (DF <sub>H</sub> )	Total docket pieces
224 (E0 <sub>H</sub> )	Number of docket adds
225 (E1 <sub>H</sub> )	Preset tare
226 (E2 <sub>H</sub> )	Counting sample weight
227 (E3 <sub>H</sub> )	Counting sample pieces
228 (E4 <sub>H</sub> )	Counting piece weight
229 (E5 <sub>H</sub> )	Alternative weight conversion
233 (E9 <sub>H</sub> )	Last weight added
234 (EA <sub>H</sub> )	Last alternative weight added
235 (EB <sub>H</sub> )	Last pieces added
236 (EC <sub>H</sub> )	Clear docket totals
237 (ED <sub>H</sub> )	Reset last product add
238 (EE <sub>H</sub> )	Clear totals on all products
242 (F2 <sub>H</sub> )	Product ID

**Table 12: Print tokens: product information**

**16.3.5. Page 8 tokens: Miscellaneous weight data**

These tokens hold weight/alternate weight information depending on which is being displayed.

<b>Code</b>	<b>Token</b>
215 (D7 <sub>H</sub> )	Displayed reading (gross or net)
216 (D8 <sub>H</sub> )	Gross reading
217 (D9 <sub>H</sub> )	Net reading
218 (DA <sub>H</sub> )	Tare value (tare or preset tare)
219 (DB <sub>H</sub> )	Status 12: weight units: <b>Kg, Lb</b> , ‘ ‘
220 (DC <sub>H</sub> )	Status 13: <b>Gross, Net</b>
221 (DD <sub>H</sub> )	Status 14: <b>Overload/underload, Motion</b> , ‘ ‘
222 (DE <sub>H</sub> )	Piece reading
223 (DF <sub>H</sub> )	Counting piece weight
224 (E0 <sub>H</sub> )	Status 15: <b>GS</b> (gross), <b>NT</b> (net) (uses last weight sent)
225 (E1 <sub>H</sub> )	Tilt X (K491 only)
226 (E2 <sub>H</sub> )	Tilt Y (K491 only)
227 (E3 <sub>H</sub> )	Tilt XY (K491 only)

**Table 12: Print tokens: weight information**

### 16.3.6. Format tokens

Format tokens define the behaviour of all subsequent tokens in a string.

Code	Format Tokens
149 (95 <sub>H</sub> )	5 character weight string, decrementing to 3 with wrapping (5,4,3,5...)
150 (96 <sub>H</sub> )	6 character weight string
151 (97 <sub>H</sub> )	7 character weight string
152 (98 <sub>H</sub> )	8 character weight string
153 (99 <sub>H</sub> )	9 character weight string
154 (9A <sub>H</sub> )	10 character weight string
155 (9B <sub>H</sub> )	No sign characters
156 (9C <sub>H</sub> )	Sign is '+' for positive and '-' for negative
157 (9D <sub>H</sub> )	Sign is '0' for positive and '-' for negative
158 (9E <sub>H</sub> )	Sign is '+' for positive and '-' for negative
159 (9F <sub>H</sub> )	No decimal point
160 (A0 <sub>H</sub> )	Decimal point is '.'
161 (A1 <sub>H</sub> )	Decimal point is ','
162 (A2 <sub>H</sub> )	Weight sent without leading characters
163 (A3 <sub>H</sub> )	Weight sent with '+' for leading characters
164 (A4 <sub>H</sub> )	Weight sent with '0' for leading characters
165 (A5 <sub>H</sub> )	Show weight on error
166 (A6 <sub>H</sub> )	Show dashes instead of weight on error
167 (A7 <sub>H</sub> )	Show spaces instead of weight on error
168 (A8 <sub>H</sub> )	Use uppercase status characters
169 (A9 <sub>H</sub> )	Use lowercase status characters
170 (AA <sub>H</sub> )	Hide units
171 (AB <sub>H</sub> )	Show decimal point even if it is at the end of a number
172 (AC <sub>H</sub> )	Turn page and line tracking off
173 (AD <sub>H</sub> )	Toggle space between weight and units
174 (AE <sub>H</sub> )	Increment the length or print IDs with wrapping from 6 to 9
175 (AF <sub>H</sub> )	Don't show weight

**Table 13: Print tokens: formatting**

Printouts have default format tokens of line and page tracking are enabled and:

Weight	Time
<ul style="list-style-type: none"> <li>• 8 character weight string</li> <li>• Decimal point symbol is '.'</li> <li>• Leading characters are spaces</li> <li>• Weight is sent on error</li> <li>• Positive sign is space, negative sign is '-'</li> <li>• Weights are displayed with units</li> <li>• Status characters are uppercase</li> </ul>	<ul style="list-style-type: none"> <li>• Date separator is '/'</li> <li>• Time separator is ':'</li> <li>• Date format is the format configured in the setup menu</li> <li>• Time is 24 hour</li> </ul>

The Format token must be used before the token that requires the formatting. For example where the current weight is 10kg and a formatted with no units is needed:

`\BE\AA\D7` would be 10

Whereas if the AA is used after the D7 it has no effect.

`\BE\D7\AA` would be 10kg

## 17. Appendix 3: Communications Registers

Register addresses shown in both Hex (<sub>H</sub>) and decimal (<sub>d</sub>)

Name	Address	Type	Description																														
Software Model	0003 <sub>H</sub> 3 <sub>d</sub>	String	Returns software loaded (eg K402)																														
Software Version	0004 <sub>H</sub> 4 <sub>d</sub>	String	Returns software version (eg V1.0)																														
Serial Number	0005 <sub>H</sub> 5 <sub>d</sub>	Number	Returns instrument serial number																														
Key buffer entry	0008 <sub>H</sub> 8 <sub>d</sub>	Number	<p>Adds a key to the key buffer. The short press key codes are shown below. For long presses, set the most significant bit to 1. Key codes are:</p> <table style="width: 100%; border: none;"> <tr> <td>00<sub>H</sub>: 0</td> <td>0E<sub>H</sub>: F1</td> <td>15<sub>H</sub>: DOWN</td> </tr> <tr> <td>:</td> <td>0F<sub>H</sub>: F2</td> <td>16<sub>H</sub>: OK</td> </tr> <tr> <td>09<sub>H</sub>: 9</td> <td>10<sub>H</sub>: F3</td> <td>17<sub>H</sub>: SETUP</td> </tr> <tr> <td>0A<sub>H</sub>:</td> <td>11<sub>H</sub>: +/-</td> <td>20<sub>H</sub>: IO1</td> </tr> <tr> <td>Power</td> <td>12<sub>H</sub>: DP</td> <td>:</td> </tr> <tr> <td>0B<sub>H</sub>:</td> <td>13<sub>H</sub>: CANCEL</td> <td>3F<sub>H</sub>: IO32</td> </tr> <tr> <td>Zero</td> <td>14<sub>H</sub>: UP</td> <td></td> </tr> <tr> <td>0C<sub>H</sub>:</td> <td></td> <td></td> </tr> <tr> <td>Tare</td> <td></td> <td></td> </tr> <tr> <td>0D<sub>H</sub>: G/N</td> <td></td> <td></td> </tr> </table>	00 <sub>H</sub> : 0	0E <sub>H</sub> : F1	15 <sub>H</sub> : DOWN	:	0F <sub>H</sub> : F2	16 <sub>H</sub> : OK	09 <sub>H</sub> : 9	10 <sub>H</sub> : F3	17 <sub>H</sub> : SETUP	0A <sub>H</sub> :	11 <sub>H</sub> : +/-	20 <sub>H</sub> : IO1	Power	12 <sub>H</sub> : DP	:	0B <sub>H</sub> :	13 <sub>H</sub> : CANCEL	3F <sub>H</sub> : IO32	Zero	14 <sub>H</sub> : UP		0C <sub>H</sub> :			Tare			0D <sub>H</sub> : G/N		
00 <sub>H</sub> : 0	0E <sub>H</sub> : F1	15 <sub>H</sub> : DOWN																															
:	0F <sub>H</sub> : F2	16 <sub>H</sub> : OK																															
09 <sub>H</sub> : 9	10 <sub>H</sub> : F3	17 <sub>H</sub> : SETUP																															
0A <sub>H</sub> :	11 <sub>H</sub> : +/-	20 <sub>H</sub> : IO1																															
Power	12 <sub>H</sub> : DP	:																															
0B <sub>H</sub> :	13 <sub>H</sub> : CANCEL	3F <sub>H</sub> : IO32																															
Zero	14 <sub>H</sub> : UP																																
0C <sub>H</sub> :																																	
Tare																																	
0D <sub>H</sub> : G/N																																	
Secondary Display Left	000E <sub>H</sub> 14 <sub>d</sub>	String	Write to this register to display data on left side of Secondary Display. Note: The display must be in Top mode.																														
Secondary Display Right	000F <sub>H</sub> 15 <sub>d</sub>	String	Write to this register to display data on left side of Secondary Display. Note: The display must be in Top mode.																														
Save Settings	0010 <sub>H</sub> 16 <sub>d</sub>	Execute	Execute function with no parameters saves any FULL or SAFE setup changes. Operator changes are saved automatically																														
Enter Full Passcode	0019 <sub>H</sub> 25 <sub>d</sub>	Number	<p>Write a Passcode to this register to unlock settings protected by a FULL Passcode. If a full passcode has been set, this must be done before any registers (which require a full passcode) are accessed.</p> <p>Example: Sent (passcode 1):20120019; Response: 81120019:0000</p>																														
Enter Safe Passcode	001A <sub>H</sub> 26 <sub>d</sub>	Number	Write a Passcode to this register to unlock settings protected by a SAFE Passcode																														
ADC Sample Number	0020 <sub>H</sub> 32 <sub>d</sub>	Number	Read current sample number since last power on. (32 bit)																														
System Status *	0021 <sub>H</sub> 33 <sub>d</sub>	Number	<p>This register can be read to obtain the status of the instrument.</p> <p>32 status bits sent as 8 hex chars, where:</p> <table style="width: 100%; border: none;"> <tr> <td>00020000<sub>H</sub>:</td> <td>Overload</td> </tr> <tr> <td>00010000<sub>H</sub>:</td> <td>Underload</td> </tr> <tr> <td>00008000<sub>H</sub>:</td> <td>Error (see System Error)</td> </tr> <tr> <td>00004000<sub>H</sub>:</td> <td>SETUP menus active</td> </tr> <tr> <td>00002000<sub>H</sub>:</td> <td>Calibration in progress</td> </tr> <tr> <td>00001000<sub>H</sub>:</td> <td>Motion</td> </tr> <tr> <td>00000800<sub>H</sub>:</td> <td>Centre of Zero</td> </tr> <tr> <td>00000400<sub>H</sub>:</td> <td>Zero</td> </tr> </table>	00020000 <sub>H</sub> :	Overload	00010000 <sub>H</sub> :	Underload	00008000 <sub>H</sub> :	Error (see System Error)	00004000 <sub>H</sub> :	SETUP menus active	00002000 <sub>H</sub> :	Calibration in progress	00001000 <sub>H</sub> :	Motion	00000800 <sub>H</sub> :	Centre of Zero	00000400 <sub>H</sub> :	Zero														
00020000 <sub>H</sub> :	Overload																																
00010000 <sub>H</sub> :	Underload																																
00008000 <sub>H</sub> :	Error (see System Error)																																
00004000 <sub>H</sub> :	SETUP menus active																																
00002000 <sub>H</sub> :	Calibration in progress																																
00001000 <sub>H</sub> :	Motion																																
00000800 <sub>H</sub> :	Centre of Zero																																
00000400 <sub>H</sub> :	Zero																																

Name	Address	Type	Description
			00000200 <sub>H</sub> : Net For calibration, bit 13 (00002000 <sub>H</sub> ) is high when a calibration is taking place. Example: Send (status):20110021; Response (not calibrating): 81110021:00008400 Or Response (calibrating): 81110021:0000A400
System Error	0022 <sub>H</sub> 34 <sub>d</sub>	Number	Diagnostic Errors
Absolute mV/V	0023 <sub>H</sub> 35 <sub>d</sub>	Number	Absolute mV/V reading where 10000 = 1.0mV/V
Unused	0024 <sub>H</sub> 36 <sub>d</sub>	Number	
Gross/Net Weight	0025 <sub>H</sub> 37 <sub>d</sub>	Number	These registers return weight data.
Gross Weight	0026 <sub>H</sub> 38 <sub>d</sub>	Number	Read Final: 8 character Hexadecimal number. Example: 00000064 for 100 kg
Net Weight	0027 <sub>H</sub> 39 <sub>d</sub>	Number	Read Literal: Formatted string including decimal point units and Gross/Net indication. Example: " 10.0 kg N"
Tare Weight	0028 <sub>H</sub> 40 <sub>d</sub>	Number	
Peak Hold	0029 <sub>H</sub> 41 <sub>d</sub>	Number	
Manual Hold	002A <sub>H</sub> 42 <sub>d</sub>	Number	
Grand Total	002B <sub>H</sub> 43 <sub>d</sub>	Number	
Alternate Units Gross	002C <sub>H</sub> 44 <sub>d</sub>	Number	
Raw ADC counts	002D <sub>H</sub> 45 <sub>d</sub>	Number	2,560,000 = 1.0mV/V
Alternate Units Net	002E <sub>H</sub> 46 <sub>d</sub>	Number	as above
System Fullscale	002F <sub>H</sub> 47 <sub>d</sub>	Number	Fullscale weight of the instrument.
Traceable weight available flag	0030 <sub>H</sub> 48 <sub>d</sub>	Number	0: No traceable weights since start up 1: Traceable weight data is valid
Traceable ID	0031 <sub>H</sub> 49 <sub>d</sub>	Number	The unique ID for the traceable weight.
Traceable weight	0032 <sub>H</sub> 50 <sub>d</sub>	Number	Traceable weight in primary units
Traceable weight (alt)	0033 <sub>H</sub> 51 <sub>d</sub>	Number	Traceable weight in alternate units
Traceable weight (p)	0034 <sub>H</sub> 52 <sub>d</sub>	Number	Traceable weight in pieces
Traceable tare weight	0035 <sub>H</sub> 53 <sub>d</sub>	Number	Tare weight valid during traceable weight.
Traceable PT flag	0036 <sub>H</sub> 54 <sub>d</sub>	Number	0: no preset tare 1: preset tare
Traceable date: year	0037 <sub>H</sub> 55 <sub>d</sub>	Number	Date and time that the traceable was acquired.
Traceable date: month	0038 <sub>H</sub>	Number	

Name	Address	Type	Description
	56 <sub>d</sub>		
Traceable date: day	0039 <sub>H</sub>	Number	
	57 <sub>d</sub>		
Traceable date: hour	003A <sub>H</sub>	Number	
	58 <sub>d</sub>		
Traceable date: minute	003B <sub>H</sub>	Number	
	59 <sub>d</sub>		
Traceable date: second	003C <sub>H</sub>	Number	
	60 <sub>d</sub>		
Stream Data	0040 <sub>H</sub> 64 <sub>d</sub>	Block	Returns a block of data which is selected in Stream Register 1 .. 5. Use a read command to read a single set of data. Use an execute command (with a parameter of 1) to switch on automatic transmission
Stream Mode	0041 <sub>H</sub> 65 <sub>d</sub>	Option	0: Manual - read 'Stream Data' register 1: Auto sync - Data is sent whenever new readings are available. 2: Auto 10Hz – Data is sent at 10Hz 3: Auto 3Hz – Data is sent at 3Hz 4: Auto 1Hz – Data is sent at 1Hz
Stream Register 1..5	0042 <sub>H</sub> 66 <sub>d</sub> .. 0046 <sub>H</sub> 70 <sub>d</sub>	Option	1..16 selects registers from ADC Sample (0020 <sub>H</sub> ) to System Fullscale (002F <sub>H</sub> ). 17 is IO Status (0051 <sub>H</sub> )
Print Token String	004C <sub>H</sub> 76 <sub>d</sub>	String	Sends a string to the configured printer port. The string can contain print tokens.
Reply Token String	004D <sub>H</sub> 77 <sub>d</sub>	String	Same as 004C <sub>H</sub> except that the completed string is returned to the sender.
Reply registers	004E <sub>H</sub> 78 <sub>d</sub>	String	Get the value of multiple number registers in a single read. The register IDs are listed in hexadecimal. All numbers are returned as 32 bit. Example: To get the net and tare weights, send "2012004E:00270028;"
Reply Stream ID	004F <sub>H</sub> 79 <sub>d</sub>		Same as register 004E <sub>H</sub> except that stream IDs are used. Example: To get the first 3 items of stream data, send "2012004F:010203;"
IO Status	0051 <sub>H</sub> 81 <sub>d</sub>	Number	32 bits of IO status sent as 8 hex chars
Piece Weight	0053 <sub>H</sub> 83 <sub>d</sub>	Number	The current weight in pieces
Settable Consecutive Print ID	007A <sub>H</sub> 122 <sub>d</sub>	Number	The settable consecutive print ID.
User ID strings 1 .. 5	0090 <sub>H</sub> 144 <sub>d</sub> .. 0094 <sub>H</sub> 148 <sub>d</sub>	String	These strings are also accessed via the ID function on the keypad.

Name	Address	Type	Description
The following registers relate to tilt values (K491 only)			
Tilt X	00A0 <sub>H</sub> 160 <sub>d</sub>	Number	The current tilt value in the X axis
Tilt Y	00A1 <sub>H</sub> 161 <sub>d</sub>	Number	The current tilt value in the Y axis
Tilt X Absolute	00A2 <sub>H</sub> 162 <sub>d</sub>	Number	The absolute tilt value in the X axis
Tilt Y Absolute	00A3 <sub>H</sub> 163 <sub>d</sub>	Number	The absolute tilt value in the X axis
Tilt XY	00A4 <sub>H</sub> 164 <sub>d</sub>	Number	The current tilt value
<b>The following registers relate to calibration (marked with *).</b>			
Calibration weight *	0100 <sub>H</sub> 256 <sub>d</sub>	Number	This register is used to set the calibration weight for span and linearity calibrations. Weights are sent in decimal or hexadecimal (depending on command used). They must be in displayed weight without decimal point or units. Example: <ul style="list-style-type: none"> <li>• 10.00kg → 1000 → 3E8H</li> <li>• 1000kg → 1000 → 3E8H</li> <li>• 0.1000t → 1000 → 3E8H</li> </ul> Example: Sent (10.00kg): 20120100:3E8 Response(ok): 81120100:0000
Zero calibration *	0102 <sub>H</sub> 258 <sub>d</sub>	Execute	This register is used to perform a zero calibration in the same way as the zero calibration via the menus. The display will change to indicate that a zero calibration is taking place. Example: Sent (calibrate): 20100102 Response (ok): 81110102:00000000 Send (status?): 20110021 Response (calibrating): 81110021:0000A400 Send (status?): 20110021 Response (calibrating): 81110021:0000A400 Send (status?): 20110021 Response (not calibrating): 81110021:00008400
Span calibration *	0103 <sub>H</sub> 259 <sub>d</sub>	Execute	This register is used to perform a span calibration in the same way as the span calibration via the menus. The display will change to indicate that a span calibration is taking place. The calibration weight must be entered before a span is executed using register 0100H. Example: Sent (1000kg cal weight): 20120100:3E8 Response(ok): 81120100:0000 Sent (calibrate): 20100103 Response (ok): 81110103:00000000 Send (status?): 20110021 Response (calibrating): 81110021:0000A400 Send (status?): 20110021 Response (calibrating): 81110021:0000A400 Send (status?): 20110021 Response (not calibrating): 81110021:00008400

Name	Address	Type	Description
Linearity calibration *	0104 <sub>H</sub> 260 <sub>d</sub>	Execute	<p>This register is used to perform linearity compensation. Up to 10 linearity points can be used [numbered 0 .. 9]. The calibration weight must be entered, using register 0100H, before doing a linearity calibration. The display will change to show that a linearisation is taking place. The linearisation point number is sent as a parameter [numbered 0 .. 9].</p> <p>Example:            Sent (5000kg cal weight): 20120100:1388            Response(ok): 81120100:0000            Sent (calibrate 1st point): 20100104:0            Response (ok): 81100103:00000000            Send (status?): 20110021            Response (calibrating): 81110021:0000A400            Send (status?): 20110021            Response (calibrating): 81110021:0000A400            Send (status?): 20110021            Response (not calibrating): 81110021:00008400</p>
Clear Linearity *	0105 <sub>H</sub> 261 <sub>d</sub>	Execute	<p>This register clears a previously entered linearisation calibration. There are 10 linearisation points [numbered 0 .. 9] which can be cleared separately. The linearisation point to clear is sent as a parameter.</p> <p>Example:            Sent (Clear 1st point): 20100105:0            Response (ok): 81100105:00000000</p>
Direct zero calibration*	0106 <sub>H</sub> 262 <sub>d</sub>	Execute	<p>This register is used to perform a direct zero calibration in the same way as the direct zero calibration via the menus. A direct zero calibration is very fast and the display may not change in the same way as a zero calibration.</p> <p>The mV/V value is sent as a parameter. It is sent as mV/V x 10000. Example:</p> <ul style="list-style-type: none"> <li>• 0.5mV/V → 5000 → 1388H</li> <li>• 1.0mV/V → 10000 → 2710H</li> <li>• 2.5mV/V → 25000 → 61A8H</li> </ul> <p>Example:            Sent (0.5mV/V): 20100106:1388            Response(ok): 81100106:00000000</p>
Direct span calibration*	0107 <sub>H</sub> 263 <sub>d</sub>	Execute	<p>This register is used to perform a direct span calibration in the same way as the direct span calibration via the menus. A direct span calibration is very fast and the display may not change in the same way as a span calibration.</p> <p>The mV/V value OF FULLSCALE is sent as a parameter. It is sent as mV/V x 10000. E.g:</p> <ul style="list-style-type: none"> <li>• 0.5mV/V → 5000 → 1388H</li> <li>• 1.0mV/V → 10000 → 2710H</li> <li>• 2.5mV/V → 25000 → 61A8H</li> </ul> <p>Example use:            Sent (1.0mV/V): 20100107:2710            Response(ok): 81100106:00000000</p>
Current Time/Date	0150 <sub>H</sub>	String	Read this register to get instrument date/time

Name	Address	Type	Description
	336 <sub>d</sub>		settings (eg 10/12/2005 18:30:10). (Can be SAFE Passcode protected)
Date Format	0151 <sub>H</sub> 337 <sub>d</sub>	Option	Write 0 for MMDDYYYY or 1 for DDMMYYYY
Day	0152 <sub>H</sub> 338 <sub>d</sub>	Number	Read/Write current day (1..31)
Month	0153 <sub>H</sub> 339 <sub>d</sub>	Number	Read/Write current month(1..12)
Year	0154 <sub>H</sub> 340 <sub>d</sub>	Number	Read/Write current year (2000..2099)
Hour	0155 <sub>H</sub> 341 <sub>d</sub>	Number	Read/Write current hour (0..23)
Minute	0156 <sub>H</sub> 342 <sub>d</sub>	Number	Read/Write current minute (0..59)
Second	0157 <sub>H</sub> 343 <sub>d</sub>	Number	Read/Write current second (0..59)
Session Total Weight	0210 <sub>H</sub> 528 <sub>d</sub>	Number	Session total information
Session Total Alt Wgt	0211 <sub>H</sub> 529 <sub>d</sub>		
Session Total Pieces	0212 <sub>H</sub> 530 <sub>d</sub>		
Session Total Num	0213 <sub>H</sub> 531 <sub>d</sub>		
Grand Total Weight	0220 <sub>H</sub> 544 <sub>d</sub>	Number	Grand total information
Grand Total Alt Wgt	0221 <sub>H</sub> 545 <sub>d</sub>		
Grand Total Pieces	0222 <sub>H</sub> 546 <sub>d</sub>		
Grand Total Num	0223 <sub>H</sub> 547 <sub>d</sub>		
<b>The following registers relate to the DSD.</b>			
Auto clear DSD	8290 <sub>H</sub> 33424 <sub>d</sub>	Option	Auto write over oldest records when full (0..1)
Read DSD Record	8291 <sub>H</sub> 33425 <sub>d</sub>	Execute	Reads requested DSD record
Read Next DSD Record	8292 <sub>H</sub> 33426 <sub>d</sub>	Execute	Reads next DSD record
Read Prev. DSD Record	8293 <sub>H</sub> 33427 <sub>d</sub>	Execute	Reads Previous DSD record
Read Oldest Record	8294 <sub>H</sub> 33428 <sub>d</sub>	Execute	Reads Oldest DSD record
Read Newest Record	8295 <sub>H</sub> 33429 <sub>d</sub>	Execute	Reads Newest DSD record
Clear DSD	8296 <sub>H</sub> 33430 <sub>d</sub>	Execute	Clears all records on DSD
<b>The Active Product is the product shown on the instrument display. It is the product which is currently active in the instrument.</b>			
Change Active Product using Product number	B000 <sub>H</sub> 45056 <sub>d</sub>	Number	Write number to change the active product. Read to find out active product number.
Clear all Totals	B002 <sub>H</sub> 45058 <sub>d</sub>	Execute	Execute to clear All Totals

Name	Address	Type	Description
Clear Session Totals	B003 <sub>H</sub> 45059 <sub>d</sub>	Execute	Execute to clear Session Totals only
Clear Docket Totals	B004 <sub>H</sub> 45060 <sub>d</sub>	Execute	Execute to clear printing Docket Totals only
Delete all products	B005 <sub>H</sub> 45061 <sub>d</sub>	Execute	Execute to delete all products
Change Active Product using Product Name	B006 <sub>H</sub> 45062 <sub>d</sub>	String	Write name to change the active product. Read to find out name of active product.
<b>All changes to product information are made to the selected product. This product is selected via the comms and is used for network commands only. It may be different to the active product in the instrument.</b>			
Select product by name	B00F <sub>H</sub> 45071 <sub>d</sub>	String	Write name to select product, read to find out selected product name.
Select product by number	B010 <sub>H</sub> 45072 <sub>d</sub>	Number	Write number to select product, read to find out selected product number.
<b>The following registers all work with the Selected Product.</b>			
Delete	B011 <sub>H</sub> 45073 <sub>d</sub>	Execute	Execute with no parameters to delete the selected product. This can be done only if the product total is zero.
Re-name	B012 <sub>H</sub> 45074 <sub>d</sub>	String	Write to change name of selected product.
Name	B013 <sub>H</sub> 45075 <sub>d</sub>	String	Read selected product name.
Preset Tare	B015 <sub>H</sub> 45077 <sub>d</sub>	Number	Read/Write Preset Tare
Sample Size	B016 <sub>H</sub> 45078 <sub>d</sub>	Number	Read/Write Sample Size
Sample Weight	B017 <sub>H</sub> 45079 <sub>d</sub>	Number	Read/Write Sample Weight
Piece Weight	B018 <sub>H</sub> 45080 <sub>d</sub>	Number	Read/Write Piece Weight
Alternate Unit Conversion Factor	B019 <sub>H</sub> 45081 <sub>d</sub>	Number	Read/Write Conversion Factor. 1000000 = 1.0
Target 1 .. Target 8	B080 <sub>H</sub> 45184 <sub>d</sub> .. B087 <sub>H</sub> 45191 <sub>d</sub>	Number	Setpoint targets for the Selected Product
Total Weight Total Alternate Wgt Total Pieces Total Num	B102 <sub>H</sub> 45314 <sub>d</sub> .. B105 <sub>H</sub> 45317 <sub>d</sub>	Number	Product total information
Total Docket Weight Total Docket Alt Wgt Total Docket Pieces Total Docket Num	B180 <sub>H</sub> 45440 <sub>d</sub> .. B183 <sub>H</sub> 45443 <sub>d</sub>	Number	Product docket total information

Note: The viewer software will show the register address for each setting in the menu structure when they are accessed. Note that register addresses are not guaranteed to remain the same between software types and versions.

## 18. Appendix 4: Setup Menu Quick Reference

**Note:** ⊗ Read-only Safe Setup. Changing this setting **will increment** the Calibration Counter.  
 1 Read-only Safe Setup. Changing this setting **will not increment** the Calibration Counter.

L1	L2	L3	L4	Item	
GEN.OPT	LANG			Operator language	
	P.T.SCP			Preset tare scope	
	DATE.F			Date Format	
	P.CODE	SAFE.PC			Safe setup passcode
		FULL.PC			Full setup passcode
		OP.PC			Operator passcode
	KEY.LOC	P			Power key lock
		ZERO, TARE, GR.NET			Fixed Function Keys
		F1,F2,F3			Programmable Function Keys
		CLOCK, VIEW etc			Operator Functions
	DISP	B.LIGHT			Backlight operation
		FREQ			Display update frequency
		AUX.DSP			Auxiliary display function
		VIEW			Default View
	ID.NAME	NAME.1 .. NAME.5		Names for the five User ID strings	
POWER	AUT.OFF			Auto-off	
	START			Pause on Start-Up	
STR.EDT			String editor mode		
USR.DEF			User defaults (all items except scale menu items)		
H.WARE	ALLOC			Check hardware allocation and use	
	LC.HW	MVV		mV/V test	
		OL.CNT		Overload count	
		OL.CLR		Clear overload count	
	SER1.HW, SER2.HW	BAUD, PARITY, etc		Settings for serial port 1 (SER1.HW) and the optional serial port 2 (SER2.HW).	
	ETH.HW	DHCP, IP, G.WAY		IP Configuration settings for the M4221 Ethernet module	
		ETH.DEF		Reset the M4221 Ethernet module to defaults	
	IO.HW	FRC.OUT		Force outputs test	
		TST.IN		Check inputs test	
		DB.1.8 - DB.25.32	DBNC.1. DBNC.32	Debounce settings for inputs	
	ANL.HW	TYPE		Voltage or current selection	
		CLIP		Output clip enable	
		FRC.OUT		Force analog output test	
		ANL.CAL	ADJ.LO	Adjust lo output (4mA or 0V)	
			ADJ.HI	Adjust hi output (20mA or 10V)	
	DSD.HW	AUTO.C		Automatically overwrite oldest records when DSD full	
		DSD.STR		Custom string to store with DSD records	
	TILT.HW (K491 only)	ANGLE		Displays current X,Y angles	
		FACTOR		Displays current compensation factor	
		ZERO		Sets the user zero of the tilt sensor	
F.ZERO		Restores the factory zero of the tilt sensor			
SCALE	BUILD	TYPE		Range type	
		CABLE		6-WIRE or 4-WIRE	
		DP		Decimal Point position	
		CAP1		Capacity of Scale / Range 1 / Interval 1	
		E1		Resolution of Scale / Range 1 / Interval 1	
		CAP2		Capacity of Scale / Range 2 / Interval 2	
		E2		Resolution of Scale / Range 2 / Interval 2	
		UNITS		Scale Units	
		HI.RES		x10 Expanded mode	
		MAX.XY		Maximum XY Tilt setting (K491 only)	
		MAX.X		Maximum X Tilt setting (K491 only)	
		MAX.Y		Maximum Y Tilt setting (K491 only)	
		OPTION	USE		Trade Use
			FILTER		Averaging
	MOTION		Motion Detection		
	Z.RANGE		Range of Zero (%)		
	Z.TRACK		Zero Tracking		
	Z.INIT		Zero on Startup		
	Z.BAND		Band of Zero		
	EXT.EX		External excitation		
	R.ENTRY		Full access via rear button only		
	TOT.OPT		Weight type for totalising		
	CAL		ZERO		Calibrate Zero
			SPAN		Calibrate Span

L1	L2	L3	L4	Item		
		ED.LIN		Set Linearisation		
		CLR.LIN		Clear Linearisation		
		DIR.ZER		Direct mV/V Zero Calibration		
		DIR.SPN		Direct mV/V Span Calibration		
		TILT A		Tilt Compensation Factor A (K491 only)		
		TILT B		Tilt Compensation Factor B (K491 only)		
		TILT C		Tilt Compensation Factor C (K491 only)		
		TILT D		Tilt Compensation Factor D (K491 only)		
		LC.ZERO		Loadcell zero offset (K491 only)		
		DEF.CAL		Default Calibration (all scale settings to defaults)		
	QA	QA.OPT		QA Enable		
		QA.YEAR, QA.MONTH		QA Expiry Date		
		QA.DAY				
FUNC	NUM			Number of special functions		
	SF1 – SF8	TYPE		Type		
		KEY		Key assignment (Not for Thumbwheel)		
		PRT.OUT		Print: printout		
		TOTAL		Print: totalising		
		CLR.ASK		Print: Confirm clear		
		AUTO		Print: Automatic		
		IL.TYPE		Print: Interlock type		
		I.LOCK		Print: Interlock		
		SCOPE		Counting, Units: Scope		
		MODE		Units: Mode		
		UNIT		Units: Alternative unit		
		U.STR		Units: Alternative unit string		
		EDT.WGT		Counting: Edit weight		
		MAX.ADJ		Counting: Maximum adjustment % for resample		
		EDT.CNT		Counting: Edit count		
		AUT.OUT		Single: Auto Output to use		
		BLANK		Blank: Blanking function		
		IO.BAND		Thumb: Inputs connected to thumbwheel		
		FUNC		Remote Key: Function to trigger		
CLR.TOT			Report print clear totals			
THRESH		Auto-tare: Weight threshold before taring				
ZER.DLY		Auto-tare: Delay before switching to gross in zero band				
SER.NET (K401, K402, K491)	ADDR			Network address		
	NUM			Number of networks		
	NET.1 – NET.n	TYPE		Protocol type		
		SERIAL		Serial port		
		RESP		Respond with OK for simple protocol commands		
SOURCE			Source for barcode protocol			
SER.NET (K403)	ADDR			Network address		
	NUM			Number of networks		
	NET.1 – NET.n	TYPE		Protocol type		
		SERIAL		Serial port		
		INP.1		User defined input (USER.DEF protocol only)		
CMD.1			User defined command (USER.DEF protocol only)			
SER.AUT	NUM			Number of Serial outputs		
	AUTO.1 – AUTO.n	TYPE		Frequency		
		SERIAL		Serial port		
		FORMAT		Format		
		SOURCE		Weight type		
		EV.AUTO		Custom format string		
PRINT	NUM			Number of printouts		
	HEADER			Header		
	FOOTER			Footer		
	PAGE	WIDTH			Page width	
		HEIGHT			Page Height	
		PG.END			Page End String	
	SPACE	TOP			Blank lines at the top	
		LEFT			Blank characters on the left	
		BOTTOM			Blank lines at the bottom	
	PRINT.1 – PRINT.n	TYPE			Printout type	
		FORMAT			Format	
		SERIAL			Serial port	
		NAME			Name	
		CUSTOM	REC.PRN			Custom string for record printout
			DOC.PRN			Custom string for docket printout
	EV.D.NEW				Custom string for new docket	

L1	L2	L3	L4	Item
			<b>EV.D.END</b>	Custom string for end of docket
			<b>EV.P.NEW</b>	Custom string for new product
			<b>EV.P.END</b>	Custom string for end of product
			<b>REP.ST</b>	Custom string for start of report
			<b>REP.PR</b>	Custom string for each product in a report
			<b>REP.END</b>	Custom string for end of report
<b>SETP</b>	<b>NUM</b>			Number of Setpoints
	<b>SETP1 .. SETP8</b>	<b>TYPE</b>		Type of setpoint
		<b>OUTPUT</b>		Output to use
		<b>LOGIC</b>		Active High or Active Low logic control
		<b>ALARM</b>		Setpoint Alarm
		<b>SOURCE</b>		Target value source
		<b>SCOPE</b>		Product or global targets
		<b>HYS</b>		Hysteresis
		<b>MASK</b>		Logic setpoint mask
		<b>DLY.ON</b>		Logic setpoint delay on
		<b>HLD.OFF</b>		Logic setpoint hold off
		<b>RDY.TIM</b>		Scale ready setpoint wait time
		<b>REG</b>		Register to use as source
		<b>NAME</b>		Name of the setpoint
<b>ANL.OUT</b>	<b>ABS</b>			Use absolute weight
	<b>SOURCE</b>			Weight type
	<b>RANGE</b>			Weight range
	<b>WGT.LO</b>			Weight for low transmission
	<b>WGT.HI</b>			Weight for high transmission
<b>End</b>	<b>End</b>			Save and Close

Table 13: Menus

## 19. Appendix 5: Error Messages

### 19.1. Overview

A number of error messages may be displayed to warn of operation outside of the acceptable limits. These messages may appear on either the primary or the secondary display. Short messages (XXXXXX) will appear as a single message. Longer messages (XXXXXX) (YYYYYY) will appear on the display in two parts, first the (XXXXXX) part, then the (YYYYYY) part.

### 19.2. Weighing Errors

These messages show status messages or errors that may occur during normal weighing operation.

Error	Description	Resolution
(U.LOAD)	The weight is below the minimum allowable weight reading.	Increase the weight or decrease the minimum allowable weight reading.
(O.LOAD)	The weight is above the maximum allowable weight reading. Warning - overloading may damage mechanical scale elements.	Check the condition of load cell connections. Check for damaged load cell.
(ERROR) (RANGE)	The weight reading is beyond the limit set for Zero operation. The operation of the <ZERO> key is limited in the setup during installation. The indicator cannot be Zeroed at this weight.	Increase the Zero Range (Z.RANGE) or use the <TARE> key instead.
(ERROR) (MOTION)	Scale motion has prevented a <ZERO> or <TARE> operation from occurring on command.	Try the operation again once the scale is stable.
(ERROR) (ADC)	An error with the ADC has prevented a <ZERO> or <TARE> operation from occurring	Ensure loadcell cabling is correct.
(TILT.HI) (K491 only)	The X angle has exceeded MAX.X setting, the Y angle has exceeded the MAX.Y setting, the combined XY angle has exceeded the MAX.XY setting or has exceeded the maximum tilt range of the sensor	Operate the system within these limits.

Table 14: Errors: weighing

### 19.3. Setup Errors

These messages show status messages or errors that may occur during the instrument setup. See section 8.4 for calibration errors.

Error	Description	Resolution
(ENTRY) (DENIED)	When accessing setup, more than three attempts have been made with the incorrect passcode.	Turn the instrument off. When the instrument is turned back on, enter the correct passcode to access setup.
(WR DENIED) (RD DENIED)	The instrument may be in Safe Setup and an item that	Access Full Setup to access this item.

Error	Description	Resolution
	needs Full Setup has been selected for editing.	

**Table 15: Errors: setup****19.4. Diagnostic Errors**

The instrument continually monitors the condition of the internal circuits. Any faults or out-of-tolerance conditions are shown on the display as an **E** type error message.

In the table below the following terms are used:

- **Check:** This item can be checked on site by service personnel.
- **Return for Service:** The instrument must be returned for factory service.

Error	Description	Resolution
(E0001)	The power supply voltage is too low.	Check supply
(E0002)	The power supply voltage is too high.	Check scale / cables
(E0004)	Positive sense voltage out or range.	Check scale connections and SCALE:BUILD:CABLE setting.
(E0008)	Negative sense voltage out or range.	Check scale connections and SCALE:BUILD:CABLE setting.
(E0010)	Temperature is outside of allowable limits	Check location
(E0020)	Module Error	Replace Module
(E0040)	Data not received from Tilt Sensor	Check Tilt Sensor
(E0200)	The calibration information has been lost.	Re-calibrate
(E0400)	The factory information has been lost.	Return for Service
(E0800)	Application settings have been set to defaults.	Check and re-enter application settings
(E2000)	ADC Out of Range Error. This may be caused from a broken load cell cable.	Check BUILD:CABLE setting. Check load cell cable, wiring, etc.
(E4000)	The runtime information has been lost.	Check Zero and tare settings.

**Table 16: Errors: diagnostic**

The **E** type error messages are additive. For example if instrument is running off batteries and the temperature drops, the battery voltage may be too low. The resulting error messages will be **E 0011** (0001 + 0010). The numbers add in hexadecimal as follows:

**1 - 2 - 3 - 4 - 5 - 6 - 7 - 8 - 9 - A - B - C - D - E - F**  
 (For example, 2 + 4 = 6, or 4 + 8 = C)

## 20. Appendix 6: M4221 Ethernet Module

### 20.1. Overview

The M4221 Ethernet module provides IP (internet protocol) connectivity to the indicator. The information in this appendix only applies to indicators fitted with this module.

### 20.2. Network Configuration

After installing the module, and connecting it to the network it is necessary to configure the network settings for the module. These settings may be automatically configured from your network via DHCP (Dynamic Host Configuration Protocol), or may need to be set manually. Contact your network administrator for settings appropriate to your network. The DHCP setting, IP address, network mask, default gateway and DNS servers are configured from the indicator via the ETH.HW menu (Section 7.2.4 on page 48). Additionally a host name & DHCP client ID may be optionally configured from the Module web page.

### 20.3. Viewing the Current Configuration

The Acc menu provides access to the current IP configuration of the module. Refer to Section 5.2.15 on page 38.

### 20.4. Services

The M4221 provides a number of services via the network, including a configuration web page and two TCP ports providing access to the indicators' serial ports SER.3A and SER.3B.

#### 20.4.1. TCP Sockets

SER.3A can be accessed via TCP port 2222 on the module. This port allows only one simultaneous connection as it is bi-directional

SER.3B can be accessed via TCP port 2223 on the module. This port allows up to 10 simultaneous connections, as it is transmit only (data is sent from the indicator to the PC).

As with other serial modules, it is necessary to configure a function (networking, printing or auto-outputs) on the indicator to communicate via SER.3A or SER.3B.

The Viewer software can be used to test the connection to the indicator. This requires Viewer version 1.44+. Select a TCP connection from the connection settings dialog, and enter the indicator IP address or hostname. The TCP port should be set to 2222.

#### 20.4.2. Web Interface

There is a Web page provided by the module. This can be accessed by determining the IP address from the Acc menu, and then entering the following into your web browser: `http://<module_ip_address>/`. The default username for the module web page is "admin", and the default password is "PASS".

## 21. Appendix 7: M4501 DSD Module

### 21.1. Overview

The M4501 DSD module provides alibi memory along with custom string support. The information in this appendix applies only to indicators fitted with this module.

### 21.2. Writing records

A record will be stored in the DSD whenever a traceable weight is generated, A traceable weight is only generated when a print of type RECORD or DOCKET occurs, and only for TOTAL values of NONE or ADD. For more information on print setup see sections 7.8 PRINT (Printouts) on page 67 and 11 Printing on page 89. The DSD will also be written when a print occurs in alibi mode.

If a custom string is set then it will be stored along with the traceable weight. The custom string accepts all print tokens. For more information on the custom string and auto clear settings see section 7.2.8 DSD.HW on page 50.

### 21.3. Reading records

The records can be viewed in alibi mode or read through the communications interface. For more information on viewing DSD records in alibi mode see section 5.2.14 Alibi on page 37. View400 can be used to retrieve the records from the instrument or you can manually send communications commands to the instrument. For a list of registers relating to reading DSD record via the comms interface see section 17 Appendix 3: Communications Registers on page 123.

The reply to a DSD record read command will look like the following example:

```
81108295:1,2009/08/04,11:12:24, 2000,kg,GROSS, 0,kg,TARE,
4410,lb,13,p
```

This response is comma separated and contains the following data:

Response header: record ID, date, time, weight, units, gross/net, tare weight, tare units, tare/P.tare., alternate weight, alternate units, piece count, piece units, custom string

If the custom string DSD.STR: \BA\D7,\C9 is set then the reply will be:

```
81108295:2,2009/08/04,12:12:08, 950,kg,NET, 50,kg,P.TARE, 2095,lb, 6,p
,FLOUR ,AA MINES
```

See section 16.3 Tokens on page 119 for information on the print tokens used in the above example.

## 22. Glossary

### 22.1. Glossary of Terms

Term	Definition
Count-by	The smallest change in weight units that the display can show. See also Resolution.
Division	A single graduation.
EEPROM	Electrically Erasable Programmable Read-Only Memory
EMC	Electro-Magnetic Compatibility Regulation
FIR	Finite Impulse Response
Full Scale	The maximum gross weight allowed on the scale. This is used to detect overload and underload conditions, etc.
Graduations	The maximum number of display steps between zero gross load and full capacity gross load. It is equal to the full scale divided by the resolution.
LED	Light Emitting Diode
NTEP	National Type Evaluation Program
OIML	International Organization of Legal Metrology
PLC	Programmable Logic Controller
Range	Total change in weight between zero gross load and full capacity gross load (i.e. the nominated total capacity of the scale). It is always given in displayed weight units.
Resolution	The smallest change in weight units that the display can show. See also Count-by.
RFI	Radio Frequency Interference
Ring Network	A network of up to 31 Instruments connected to a central computer
Optical Communications Cable	Opto-isolated infrared communications cable which uses a magnetically coupled head to attach to the front of the instrument
RS-232	Standard for communications hardware layers.
Step-Response	The step-response is the time between placing a weight on the scale and the correct weight reading being displayed.
Transients	A temporary voltage oscillation or spike caused by a sudden change of load (or other external influence).
Units	The actual units of measurement (kilograms, tonnes, pounds, etc.).

**22.2. List of Figures**

Figure 1: Weight Indicator .....	6
Figure 2: Cable Connections .....	10
Figure 3: 4-Wire Connections.....	11
Figure 4: Loadcell Connections.....	11
Figure 5: RS-232 - Instrument to PC using COM Port (DB9).....	12
Figure 6: RS-232 – Instrument to Printer (DB25) .....	12
Figure 7: RS-232 Short Cable Runs (Ring Network using COM Port) .....	13
Figure 8: RS-232 Long Cable Runs (Ring Network using COM Port) .....	14
Figure 9: Optical Communications attachment.....	16
Figure 10: Cable Shield Connection .....	17
Figure 11: Chart - Zero and Span Points to Interpolate Weight from Load Cell .....	72
Figure 12: Chart - Non-Linear Characteristic for Load Cell Output.....	77
Figure 13: OVER versus UNDER setpoints.....	108
Figure 14: Trade label position.....	115
Figure 15: Lead seal on rear of instrument.....	116
Figure 16: Lead seal on boot.....	116
Figure 17: Destructible sticker seal on rear of instrument.....	117
Figure 18: Destructible sticker seal on boot.....	117

**22.3. List of Tables**

Table 1: Document Conventions.....	7
Table 2: Instrument specifications .....	8
Table 3: Industrial vs trade modes.....	40
Table 4: Calibration errors .....	79
Table 4: Tilt Calibration errors.....	80
Table 5: Network error codes.....	83
Table 6: Dimensions .....	113
Table 7: ASCII Table .....	118
Table 8: Print tokens: generic.....	119
Table 9: Print tokens: pages.....	119
Table 10: Print tokens: weight information.....	120
Table 11: Print tokens: product information .....	121
Table 12: Menus.....	132
Table 13: Errors: weighing.....	133
Table 14: Errors: setup .....	134
Table 15: Errors: diagnostic.....	134

## 23. Index

- 4**  
4-Wire Connection, 10
- 6**  
6-Wire Connection, 11
- A**  
Automatic Weight Output, 88  
Auxiliary Connection, 11
- B**  
Basic Weighing Terminology, 39
- C**  
Cable Connections, 9  
Calibration, 72  
Calibration Counter, 40  
Clear Linearisation, 78  
CLR.LIN, 78  
Connecting Shields, 16  
COUNT, 98, 99
- D**  
Data Entry, 19  
  Numeric Entry, 21  
  Selections and Options, 22  
DC Power Supply, 10  
Diagnostic Errors, 135
- Digital Calibration with Test Weights, 72  
Direct mV/V Calibration, 76  
Direct Span Calibration, 76  
Direct Zero Calibration, 76  
Document Conventions, 7
- E**  
Earthing, 17  
ED.LIN, 78  
Edit Linearisation Points, 78  
Electrical Safety, 9  
EMC Immunity, 9  
Error Messages, 134  
Exiting Full or Safe Setup, 20
- F**  
Filtering Techniques, 39  
Front Panel Special Function Key, 96  
Full Setup Passcode, 40  
FUNCTION Key, 96
- G**  
General Setup Information, 39  
Glossary of Terms, 138
- H**  
HOLD, 103
- I**  
Industrial vs OIML and NTEP Mode, 40
- K**  
Key Functions, 96
- L**  
Load Cell Connection, 10  
Load Cell Signals, 10
- N**  
NONE, 96  
NVRAM, 6
- O**  
Optical Communications, 15
- P**  
Passcode, 39  
PEAK HOLD, 103  
Printing, 89
- R**  
RFI, 138  
RS-232 Serial, 12
- S**  
Safe Setup Passcode, 41  
Scale Build, 10  
Sealing Details, 116  
Sealing Requirements, 17, 18
- Serial PC Link, 12  
Serial Printer Connections, 12  
Serial Remote Display, 12, 14  
Setup Display Prompts, 20  
Setup Errors, 134  
Setup Menu Quick Reference, 131  
Sigma-Delta A/D converter, 6  
Span Calibration Routine, 74  
Special Functions, 96  
Specifications, 7, 8  
Stability Considerations, 38
- T**  
TARE Key, 28  
TEST, 97
- U**  
UNITS, 100  
Using Linearisation, 77
- W**  
Weighing Errors, 134
- Z**  
Zero Calibration Routine, 73  
ZERO Key, 28

Notes:

**SMART WEIGHING SOLUTIONS**

