

## Table of Contents

<b>1. INTRODUCTION</b>	<b>5</b>
1.1. Overview	5
1.2. Approvals	5
1.2.1. Trade versions	6
1.3. The Manuals Set	6
1.4. This Reference Manual	6
1.5. Document Conventions	6
<b>2. SPECIFICATIONS</b>	<b>7</b>
<b>3. INSTALLATION</b>	<b>8</b>
3.1. Introduction	8
3.2. General Warnings	8
3.3. Electrical Safety	8
3.4. Cleaning	8
3.5. Panel Mount Template	8
3.6. Cable Connections	9
3.7. DC Power (DC PWR + , DC PWR –)	9
3.8. Load Cell Connection	9
3.8.1. Load Cell Signals and Scale Build	9
3.8.2. 4-Wire Connection	10
3.8.3. 6-Wire Connection	10
3.9. Auxiliary Connections	11
3.9.1. RS-232 Serial	11
3.9.2. Remote Input	14
3.9.3. Outputs	15
3.10. opto-LINK (Optional)	16
3.11. Connecting Shields	17
3.11.1. Cable Shield Connection and Earthing	17
3.12. Regulatory Sealing Requirements	17
<b>4. DATA ENTRY</b>	<b>18</b>
4.1. Editing Annunciators	18
4.2. Numeric Entry	19
4.3. Selections and Options	19
<b>5. BASIC OPERATION</b>	<b>20</b>
5.1. Display	20
5.2. Has a key been locked?	21
5.3. Editing Function	21
5.4. Stability – What is a “Stable Error”?	21
5.5. POWER Key	21

5.6.	ZERO Key.....	22
5.7.	TARE Key.....	22
5.8.	GROSS/NET Key.....	23
5.9.	PRINT Key.....	23
5.10.	FUNCTION Key.....	23
<b>6.</b>	<b>CONFIGURATION .....</b>	<b>24</b>
6.1.	General Setup Information.....	24
6.2.	Basic Weighing Terminology.....	24
6.3.	Filtering Techniques.....	25
6.4.	Industrial vs OIML and NTEP Modes.....	25
6.5.	Calibration Counter.....	25
6.6.	Passcodes.....	26
6.6.1.	Full Setup Passcode.....	26
6.6.2.	Safe Setup Passcode.....	26
6.6.3.	Setup Lock-Out.....	26
<b>7.</b>	<b>CALIBRATION.....</b>	<b>28</b>
7.1.	Performing a Digital Calibration with Test Weights.....	28
7.1.1.	ZERO (Zero Calibration Routine).....	29
7.1.2.	SPAN (Span Calibration Routine).....	29
7.2.	Performing a Calibration with Direct mV/V Entry.....	29
7.2.1.	DIR.ZER (Direct Zero Calibration Entry).....	29
7.2.2.	DIR.SPN (Direct Span Calibration Entry).....	29
<b>8.</b>	<b>SETUP .....</b>	<b>30</b>
8.1.	Accessing Setup.....	30
8.1.1.	Access using Full Setup.....	30
8.1.2.	Access using Safe Setup.....	30
8.1.3.	Setup Display Prompts.....	31
8.2.	Exiting Full or Safe Setup.....	31
8.3.	Groups and Items.....	31
8.4.	Setup Menus.....	32
8.4.1.	BUILD (Scale Build).....	32
8.4.2.	OPTION (Scale Options).....	33
8.4.3.	CAL (Scale Calibration).....	34
8.4.4.	SPEC (Special Settings Menu).....	34
8.4.5.	CLOC (Clock) – K35*.....	37
8.4.6.	TEST (Special Test Functions).....	37
8.4.7.	FACTRY (Factory Adjustment Menu).....	38
8.4.8.	– End – (Leaving Setup).....	38
<b>9.</b>	<b>SERIAL OUTPUTS (K344, K35*).....</b>	<b>39</b>
9.1.	Serial Output Types.....	39

---

9.2.	NET - Network Communications .....	40
9.3.	Auto Weight Format String.....	40
9.4.	Menu Setup - SERIAL (Serial Communications Options) .....	41
<b>10.</b>	<b>STANDARD PRINTING – K344 (NO CLOCK/CALENDAR).....</b>	<b>43</b>
<b>11.</b>	<b>STANDARD PRINTING – K35* (WITH CLOCK/CALENDAR) .....</b>	<b>44</b>
11.1.	Printing Number of Pieces with Counting Active.....	44
11.2.	Printing Total Weight.....	45
11.3.	Printing Total Weight and Number of Pieces.....	45
<b>12.</b>	<b>PROGRAMMABLE PRINTING – K35*.....</b>	<b>46</b>
12.1.	How to set custom print strings using View 300 .....	46
12.2.	Tokens .....	46
12.3.	Using Tokens Example .....	46
12.4.	Clear Custom Print Strings.....	46
12.5.	Printing Custom Print Strings .....	47
12.6.	Master Serial Output .....	47
12.7.	Auto Output Speed.....	47
12.8.	Print Interlock .....	47
<b>13.</b>	<b>SETPOINTS – K356.....</b>	<b>48</b>
13.1.	Setpoint Menu Setup - SET.PTS.....	48
13.2.	Setpoint Configuration.....	49
13.3.	Setpoint Source .....	49
13.4.	Setpoint Target .....	49
13.5.	Setpoint Type (OVER/UNDER) and Hysteresis.....	50
<b>14.</b>	<b>SPECIAL FUNCTIONS KEY – K35* .....</b>	<b>51</b>
14.1.	Introduction .....	51
14.2.	Key Functions .....	51
14.2.1.	NONE.....	51
14.2.2.	TEST.....	51
14.2.3.	COUNT .....	51
14.2.4.	UNITS .....	51
14.2.5.	HOLD and PEAK HOLD.....	52
14.2.6.	SHOW.T .....	52
14.2.7.	HI.RES.....	52
14.2.8.	A.TARE .....	52
14.2.9.	SET.PT (K356).....	53

---

<b>15.</b>	<b>APPENDIX - TRADE SEALING DETAILS .....</b>	<b>54</b>
<b>16.</b>	<b>APPENDIX – ABS R320 DIMENSIONS .....</b>	<b>55</b>
<b>17.</b>	<b>APPENDIX – STAINLESS STEEL R323 DIMENSIONS .....</b>	<b>57</b>
<b>18.</b>	<b>SETUP MENU QUICK REFERENCE .....</b>	<b>59</b>
<b>19.</b>	<b>ERROR MESSAGES .....</b>	<b>61</b>
	19.1. Weighing Errors .....	61
	19.2. Setup and Calibration Errors .....	62
	19.3. Diagnostic Errors .....	63
<b>20.</b>	<b>APPENDIX - RINWIRE PROTOCOL.....</b>	<b>64</b>
<b>21.</b>	<b>GLOSSARY TERMS .....</b>	<b>67</b>
	21.1. List of Figures .....	67
	21.2. List of Tables.....	68
<b>22.</b>	<b>INDEX .....</b>	<b>69</b>

## 1. Introduction

This instrument is a precision digital indicator using the latest Sigma-Delta analogue to digital conversion technology to ensure fast and accurate weight readings.



**Figure 1: Weight Indicator**

The setup and calibration of the instrument are digital, with a non-volatile security store for all setup parameters.

The instrument may be operated from 4.8V, 7.2V, 9.6V, 12V or 24V batteries or a DC power source from 7V to 24V. There is a soft power on/off function that retains memory of the indicator's state. Once an instrument is turned on it will automatically start up again if the external power is interrupted.

The instrument is fitted with opto-LINK communications as standard. This allows a temporary isolated communications link to be established with a PC using an opto-LINK cable, which enables software upgrades and the use of computerised setup and calibration via the Viewer software. Refer to opto-LINK (Optional) page 16 for more information.

### 1.1. Overview

This instrument provides **ZERO** and **TARE** functionality as well as more setup options (eg. serial and setpoints) and printing functionality.

It also supports special functions (eg. peak-hold, averaging, counting, etc.), via the user definable **<FUNCTION>** key. It is equipped with an NVRAM store to ensure day-to-day operating settings (eg. **ZERO**, **TARE**, **CLOCK**, etc.), are retained when power is removed.

This instrument has two isolated transistor outputs with status display on the front panel as well as the RS-232 communications port that can be used for printer driving or connection to a remote display or PC. There is a built-in clock for date-stamping printed outputs.

### 1.2. Approvals

C-tick approved and CE approved.

### 1.2.1. Trade versions

- NMI approval (4000 divisions at 0.8 $\mu$ V/division).
- NTEP approval (10000 divisions at 0.8 $\mu$ V/division).

### 1.3. The Manuals Set

This manual is part of a set of manuals covering the setup and operation of the instrument. The set includes the following:

- **Reference Manual** - Contains detailed information on calibration and setup. This manual is intended for use by Scale Technicians who are installing the instrument.
- **Communications Manual** - Contains details on the extended networking capabilities (communications protocol).

### 1.4. This Reference Manual

There are several indicators based on the R320 with differing enclosure and mounting arrangements. This manual contains details of information common to all derivatives of the R320 series of indicators.

**Note:** In this manual any reference to the R320 includes the other indicators in the series except where stated otherwise.

### 1.5. Document Conventions

The following document conventions (typographical) are used throughout this Reference Manual.

<b>Bold Text</b>	Bold text denotes words and phrases to note.
<b>&lt;Key&gt;</b>	<b>&lt;Key&gt;</b> denotes a Keypad key. <b>Note:</b> In the Specifications section the < symbol means <b>less than</b> and the > symbol means <b>greater than</b> .
<b>^</b>	This symbol denotes one space
<b>Ä</b>	Items marked with ⊗ indicate that the setting is available only in Full Setup and is trade critical. When trade critical settings are changed the calibration counter will be incremented.

## 2. Specifications

		R320 (ABS Housing)	R323 (Stainless Steel)
<b>Resolution</b>		Up to 60,000 divisions, minimum of 0.25 $\mu$ V/division	
<b>Zero Cancellation</b>		$\pm 2.0$ mV/V	
<b>Span Adjustment</b>		0.1mV/V to 3.0mV/V full scale	
<b>Excitation</b>		5 V for up to 4 x 350 or 8 x 700 ohm load cells (4-wire or 6-wire plus shield) Max total load cell resistance: 3,500 $\Omega$ (4x350 $\Omega$ Nontrade 8x350 $\Omega$ )	
<b>A/D Type</b>		24bit Sigma Delta with 8,388,608 internal counts 20 updates/second	
<b>Operating Environment</b>		Temperature: -10° to +50°C ambient (14° to 122° F) Humidity: <90% non-condensing IP65 when panel mounted	
<b>Display</b>		LED Backlit LCD with six 20mm (0.8") high digits with units and annunciators	
<b>Setup and Calibration</b>		Full digital with visual prompting in plain messages	
<b>Digital Filter</b>		Sliding window average from 0.1 to 4.0 s	
<b>Zero Range</b>		Selectable from $\pm 2\%$ to $\pm 100\%$ Full Scale	
<b>Standard Power Input</b>		7 to 24VDC, 4.8, 9.6, 12 and 24V batteries (2.5 VA max) ON/OFF key with memory feature	
<b>Variants</b>	<b>AC</b>	AC Plug pack: 110/240VAC 50/60Hz in 12VDC 1.5A out	AC Power supply: 110/240VAC 50/60Hz in 12VDC 1.2A out
	<b>Battery</b>	12V battery pack (rechargeable NiMH)	12V battery pack (rechargeable NiMH)
		4 x AA batteries	-
<b>Case Materials</b>		ABS Housing	Stainless Steel Flush Mount
<b>Packing Weights</b>		Basic Indicator: 0.34kg (12oz)	Basic Indicator: 0.49kg (17oz)
<b>Optical Data Communications</b>		Magnetically coupled infra-red communications Conversion cables available for RS232 or USB	
		<b>K342</b>	<b>K344</b> <b>K354</b> <b>K356</b>
<b>Serial Outputs</b>		-	RS232 automatic transmit, network or printer outputs. Transmission rate: 2400, 4800, 9600 or 19200 baud
<b>Functions</b>		Manual Hold	Unit switching, counting, manual hold, peak hold,, totalising, high resolution, auto tare, display test
<b>Assignable Function Keys</b>		Fixed to Hold	1
<b>Battery Backed Clock Calendar</b>		-	Battery life 10 years minimum
<b>Input/Outputs</b>		-	2 Outputs - isolated transistor drive outputs (300mA total at 50VDC)
		-	1 Input
<b>Set points</b>		-	2
<b>Approvals</b>		4,000 d @ 0.8uV/d NMI (S-420), OIML R76 10,000d III/III L NTEP 08-072 A1 FCC, CE, C-tick,	

## 3. Installation

### 3.1. Introduction

The following steps are required to set up the indicator.

- Inspect indicator to ensure good condition.
- Use connection diagrams to wire up load cell, power and auxiliary cables as required.
- Use the panel mount template provided for hole locations.
- Connect Power to indicator and press **<POWER>** key to turn the instrument on.
- Refer to the Setup section page 30 for information on configuring and calibrating the instrument.
- To turn instrument off press and hold **<POWER>** key for three seconds (until display blanks).

### 3.2. General Warnings

- Indicator not to be subject to shock, excessive vibration or extremes of temperature (before or after installation).
- Inputs are protected against electrical interference, but excessive levels of electromagnetic radiation and RFI may affect the accuracy and stability.
- The instrument should be installed away from any sources of excessive electrical noise.
- The load cell cable is particularly sensitive to electrical noise and should be located well away from any power or switching circuits.
- For full EMC or for RFI immunity, termination of cable shields and correct earthing of the instrument is essential.
- Indicator and load cell cable are sensitive to excessive electrical noise. Install well away from any power or switching circuits.

### 3.3. Electrical Safety

- For your protection all mains electrical hardware must be rated for environmental conditions of use.
- Pluggable equipment must be installed near an easily accessible power socket outlet.
- To avoid the possibility of electric shock or damage to the instrument, always switch off or isolate the instrument from the power supply before maintenance is carried out.

### 3.4. Cleaning

- To maintain the instrument, never use harsh abrasive cleaners or solvents. Wipe the instrument with a soft cloth **slightly** dampened with warm soapy water.

### 3.5. Panel Mount Template

Use the panel mount template for drill hole locations. The template indicates positions for the two 4mm mounting screws through the panel. Also displayed on the template is the position of the rectangular hole that should be cut to allow for the connection of cables. The template supplied with the indicator allows for front or rear machining of the panel.

### 3.6. Cable Connections

All cable connections are made to the rear of the instrument using screwless terminals. Wires must be stripped of insulation by at least 10mm. To install, depress the orange lever beside the terminal required and push wire into the hole. Release the lever and pull gently on the wire to ensure it is securely trapped in the terminal. It is not necessary to tin the ends of the wire with solder or to add crimp ferrules to the wires, however, these techniques are also compatible with the terminals and may ultimately make for a neater job.

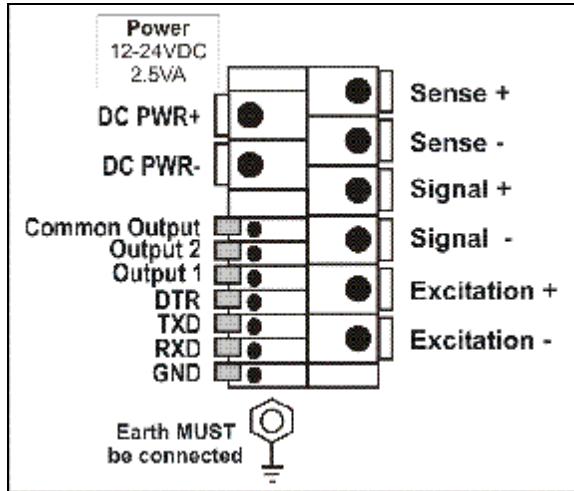

Figure 2: Cable Connections

### 3.7. DC Power (DC PWR + , DC PWR –)

The DC supply need not be regulated, provided that it is free of excessive electrical noise and sudden transients. The instrument can be operated from a high quality plug-pack as long as there is sufficient capacity to drive both it and the load cells.

If an optional battery pack is fitted, then the supplied charging system must be used.

### 3.8. Load Cell Connection

#### 3.8.1. Load Cell Signals and Scale Build

Very low output scale bases may be used but may result in some instability in the weight readings when used at higher resolutions. Generally speaking, the higher the load cell output, or the lower the number of divisions, the greater the display stability and accuracy.

The instrument can display the millivolt-per-volt reading that can be used to check scale base signal output levels. For more information, refer to TEST (Special Test Functions) page 37.

The instrument may be connected for either 4-wire or 6-wire operation. To correspond with the actual cabling installation the instrument must be configured in setup to the correct setting. For more information, refer to **CABLE**

**(4-Wire or 6-Wire)** Ä page 32.

### 3.8.2. 4-Wire Connection

The minimum connectivity requirements are the connection of four wires (ie. Excitation + and – along with Signal + and –). Internally the instrument has a precision analogue switch that connects the Sense + and – lines directly to the Excitation + and – lines when 4-wire mode is selected.

A 4-wire connection is only suitable for short cable runs. Where long cable lengths are needed, a 6-wire extension is required to maintain accuracy.

The BUILD:CABLE option must be set to **4** to allow for 4-wire connection. Refer to **CABLE**

(4-Wire or 6-Wire) Ä page 32.

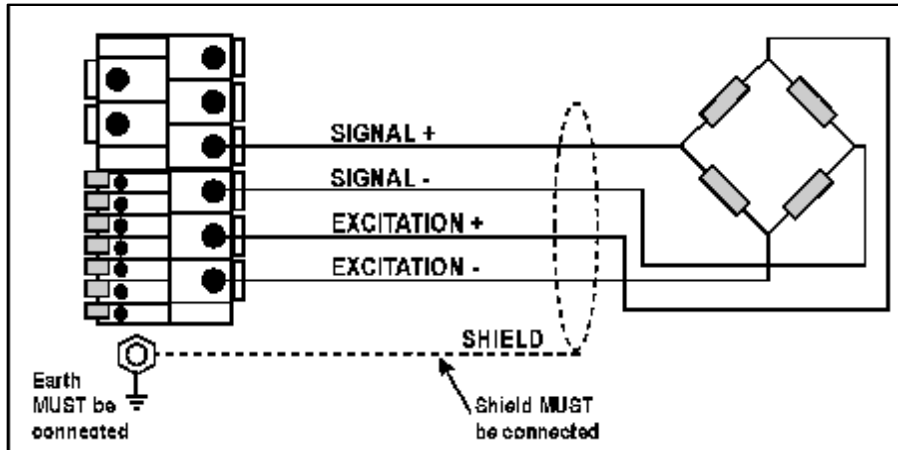

Figure 3: 4-Wire Connections

### 3.8.3. 6-Wire Connection

The excitation and signal lines are connected the same as for a 4-wire installation. The extra two wires (Sense + and –) should be connected to the Excitation + and – lines as close as possible to the load cell itself. Typically these connections are made in a load cell termination box.

The BUILD:CABLE option must be set to **6** (the default) to allow for 6-wire connection. Refer to **CABLE**

(4-Wire or 6-Wire) Ä page 32.

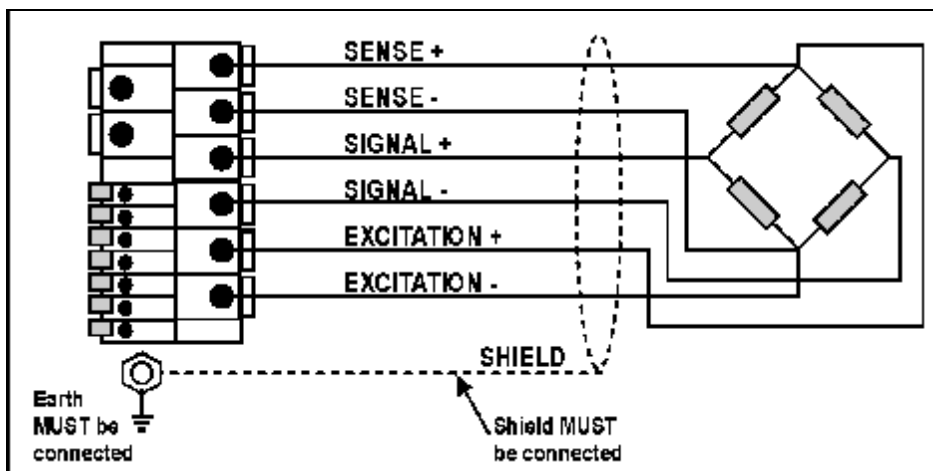

Figure 4: 6-Wire Connections

### 3.9. Auxiliary Connections

This section provides diagrams to illustrate the terminal connections.

#### 3.9.1. RS-232 Serial

Network: One Instrument to PC (RXD, TXD, GND)

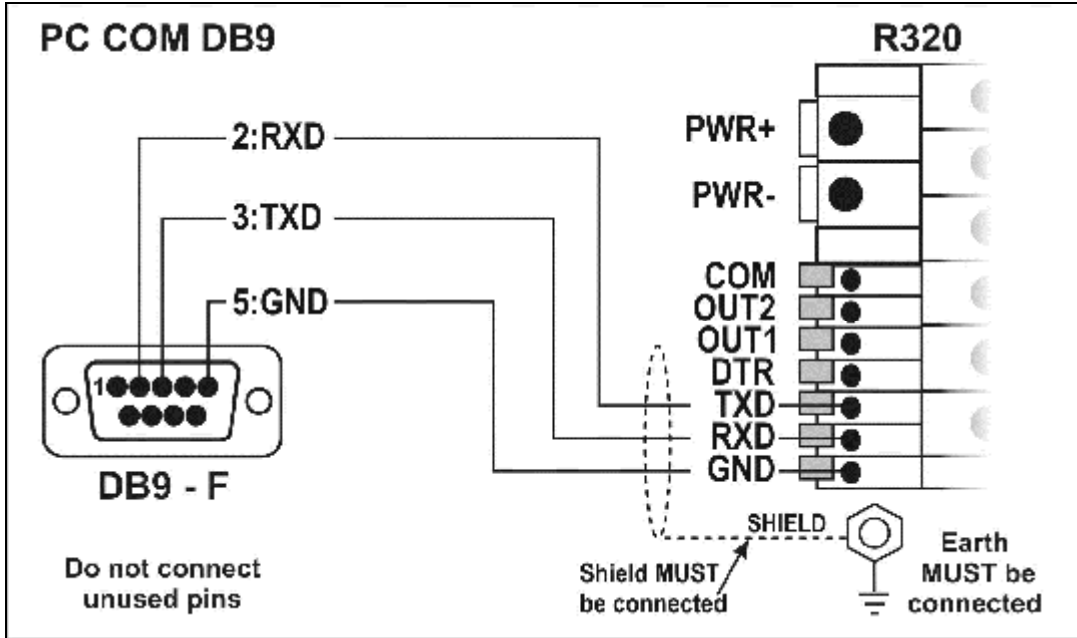

Figure 5: RS-232 – One Instrument to PC using COM Port (DB9)

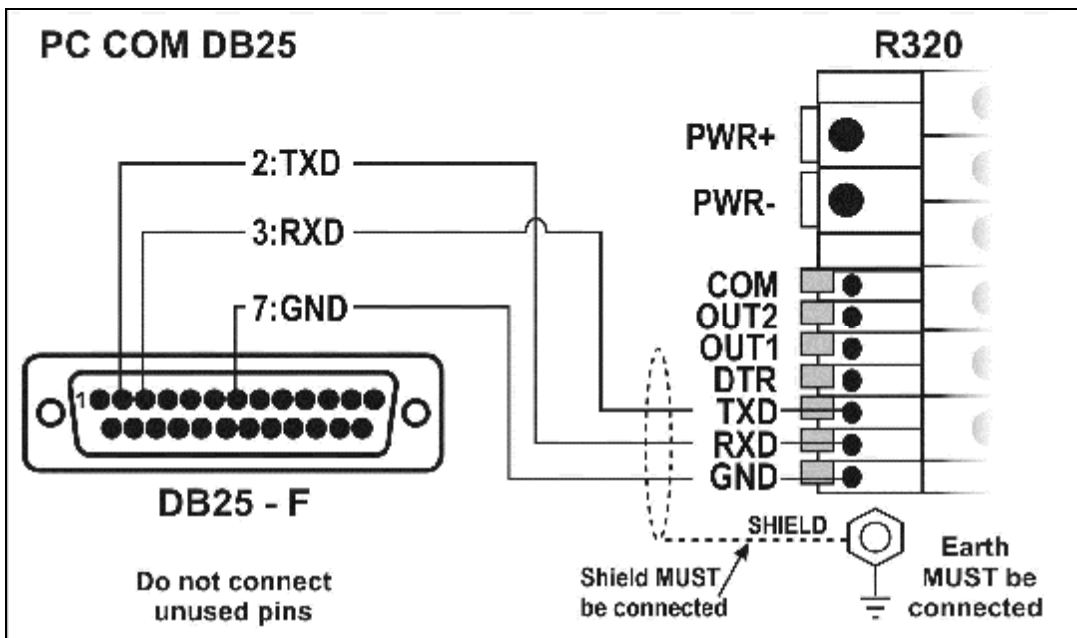

Figure 6: RS-232 – One Instrument to PC using COM Port (DB25)

## Ring Networks: Multiple Instruments to PC (RXD, TXD, GND)

Instruments can be configured in a Ring Network.

The Short Ring Network layout can be used in situations up to a total cable run length of about 150 m (500 ft) at 9600 baud in a clean EMC environment. If there are communications errors, or for longer cable runs, lower the baud rate to 4800 or 2400, and/or use the Long Ring Network in Figure 8 below, which uses a separate return path from the 'Last Instrument' to the PC.

For DB25 connections at the PC connector, refer to Figure 6 above.

When operating in a Ring Network, the Instruments must have:

- **same** serial port options, i.e., baud, parity, data bits, stop bits;
- **unique** addresses.

### Short Ring Network: Multiple Instruments to PC (RXD, TXD, GND)

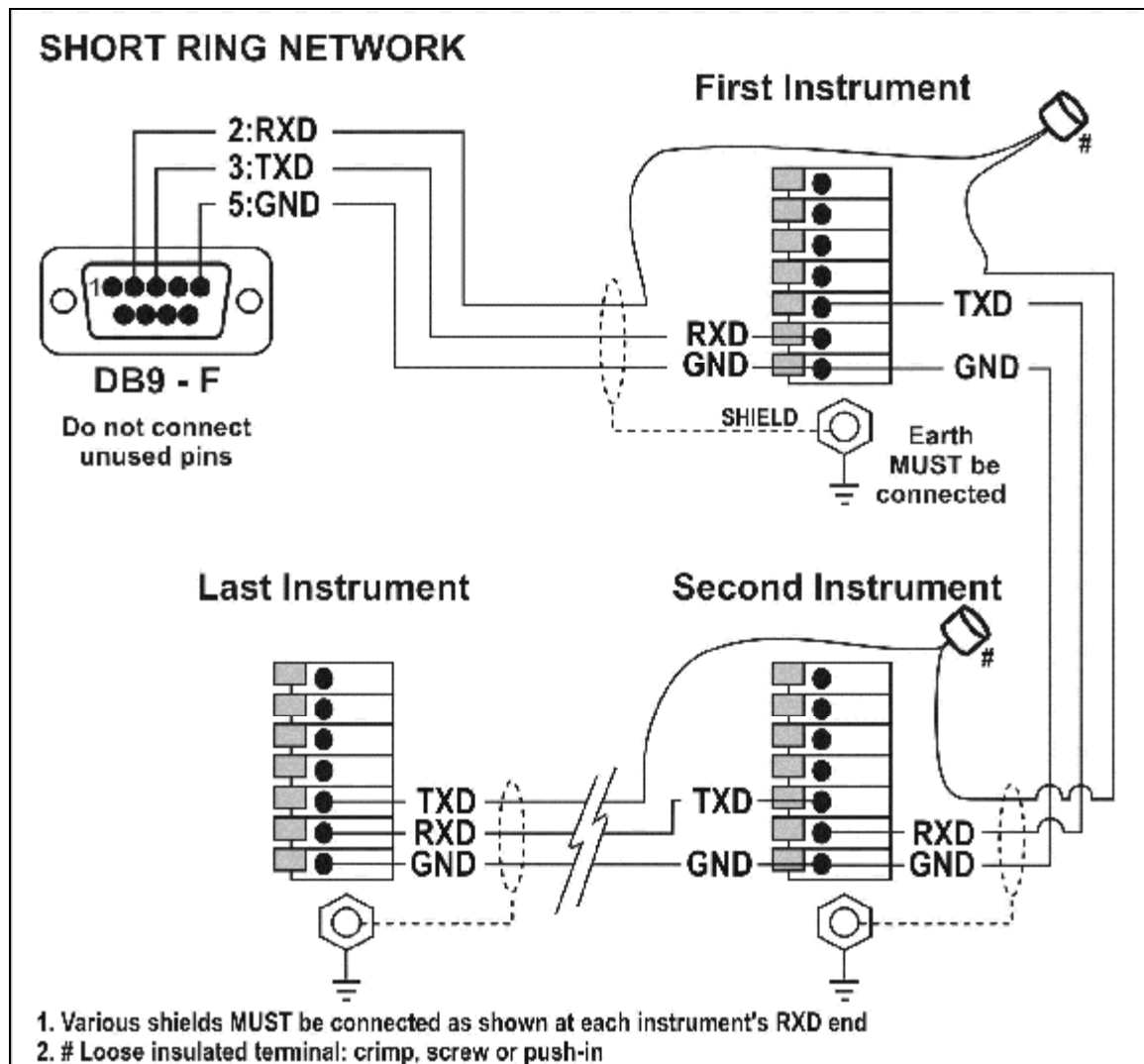
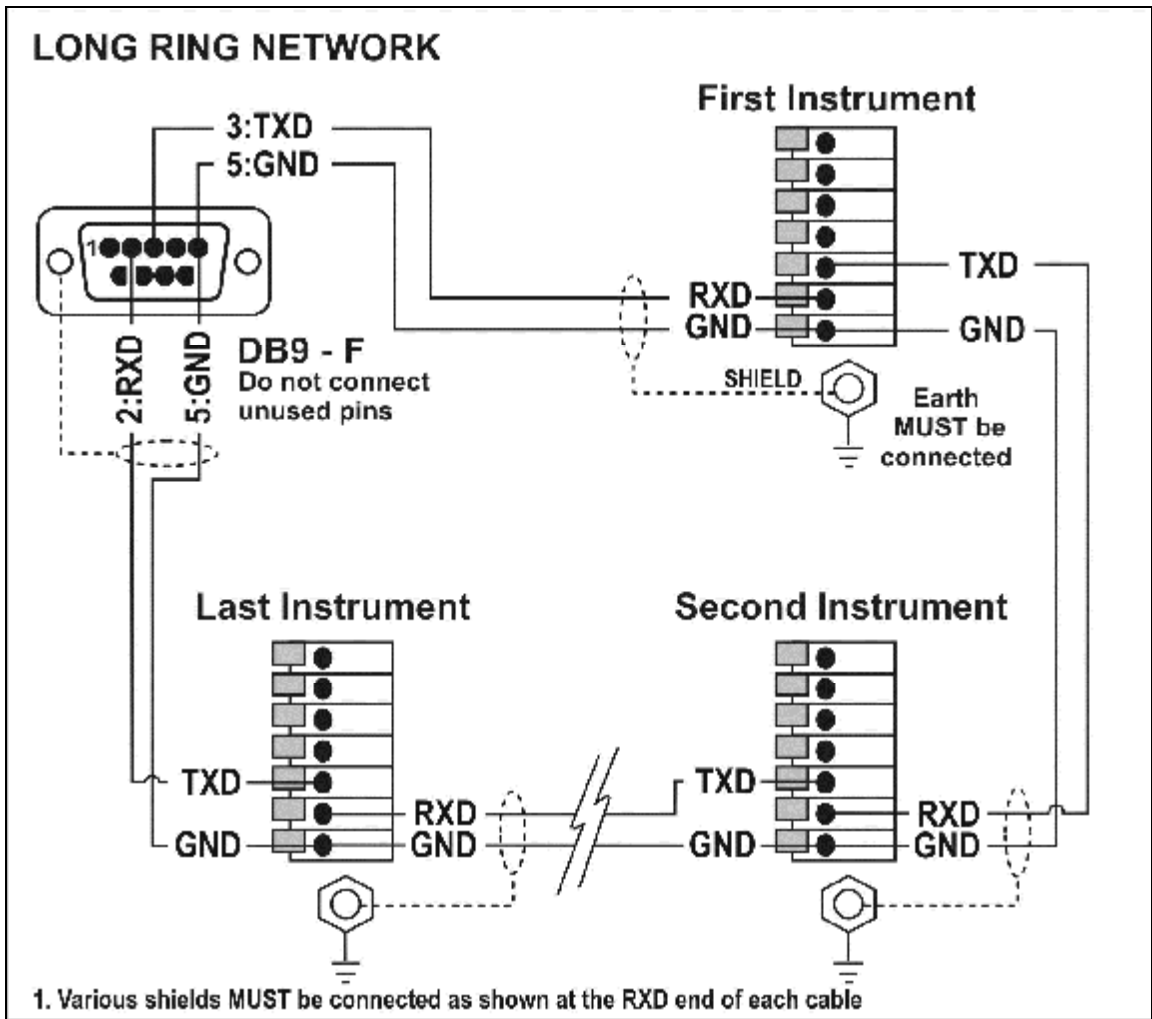

Figure 7: RS-232 Short Cable Runs: Ring Network using COM Port (DB9)

**Long Ring Network: Multiple Instruments to PC (RXD, TXD, GND)**

The Long Ring Network layout can be used in situations where each leg of the cable run can be up to about 150 m (500 ft) at 9600 baud. If there are communications errors, lower the baud rate to 4800 or 2400.



**Figure 8: RS-232 Long Cable Runs: Ring Network using COM Port (DB9)**

Printer Connections (RXD/TXD, GND and DTR)

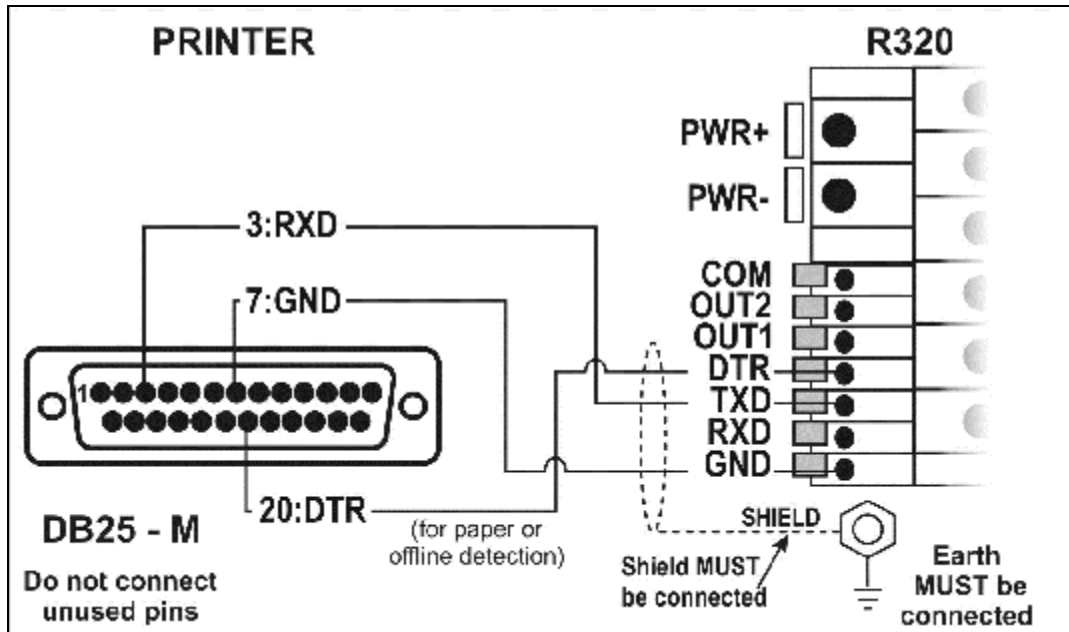

Figure 9: RS-232 – Instrument to Printer (DB25)

Remote Display (TXD, GND)

The remote display documentation should be referred to for connection details. Connect TXD to RXD and GND to GND on the remote display.

3.9.2. Remote Input

The indicator requires a voltage free contact between TXD and RXD to enable the remote input (ie. SPEC:REM.FN). The SERIAL:TYPE option must be set to AUTO, PRINT or AUTO.PR. When using SERIAL:TYPE of PRINT or AUTO.PR, the SPEC:REM.CHR must be set to an appropriate character that will not affect the printer. This character will be sent repeatedly when the transmitter is idle, regardless of the state of the DTR line. **Note:** The remote input will not function when in setup or when using the opto-LINK.

Note: Auto Output Speed must be set to 10Hz.

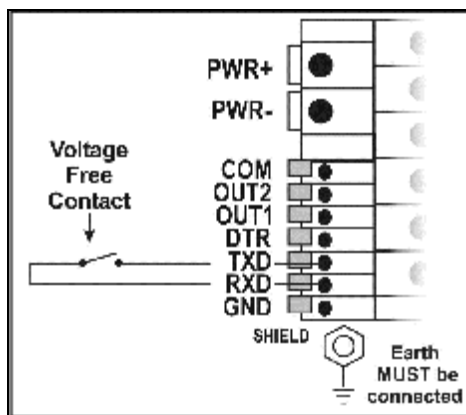

Figure 10: Remote Input

**WARNING**

The remote input is a voltage free contact (eg. button, mechanical relay). Connection of any active circuitry may damage the instrument.

### 3.9.3. Outputs

The output drivers for the instrument are isolated open emitter transistor drives that are capable of driving up to a total of 300mA. This configuration allows for the direct connection of the instrument outputs to most types of PLC.

The voltage applied to the COM terminal appears on the output lines (ie. OUT1 and OUT2) when the outputs are active (eg. to connect to a PLC connect +24V to the common terminal). The outputs can then be connected directly to PLC inputs so when activated are active the PLC will see a 22V signal (approx. - the exact switch loss will depend on loading of the output).

To drive external loads (eg. relays), connect the relay coil positive supply to the output common and the output line directly to one side of the relay coil. Connect the other end of the relay coil to the negative supply. It is recommended that fly-back diodes or transient suppressors be fitted across relay coils to limit switching noise.

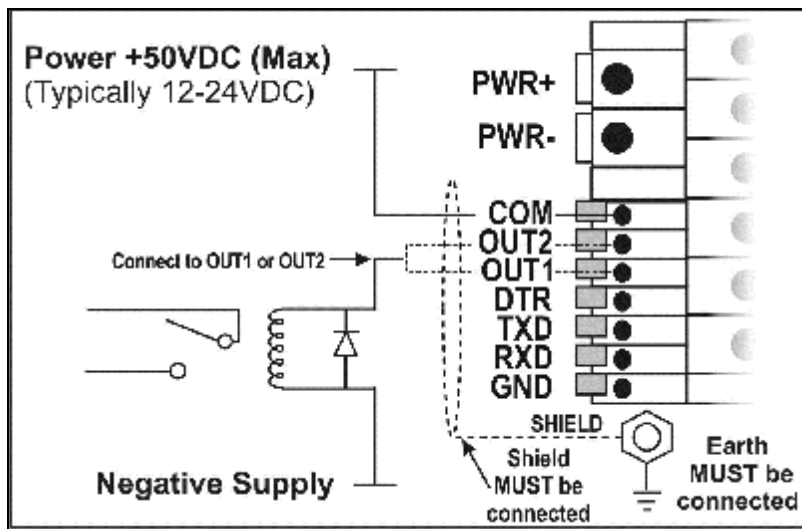

Figure 11: Instrument Outputs to Drive Relay

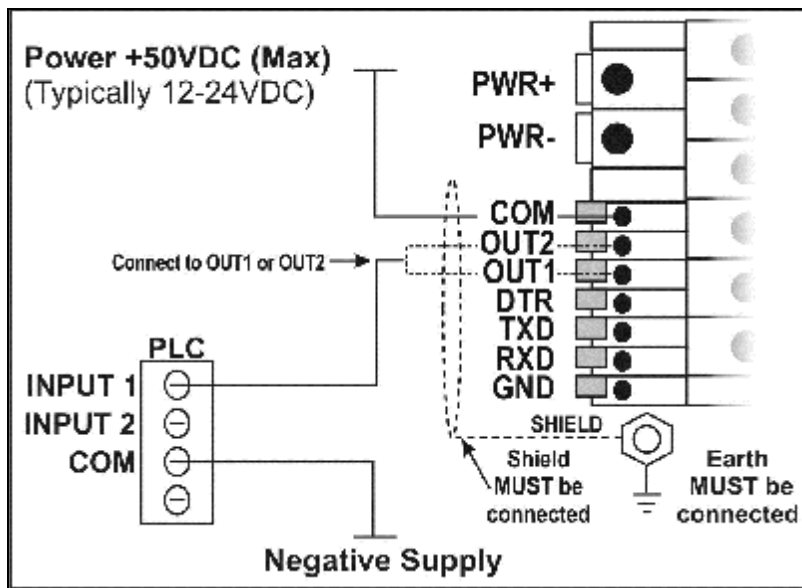

Figure 12: Instrument Outputs to Drive PLC

### 3.10. opto-LINK (Optional)

A temporary infrared communications link can be established between the instrument and a PC using an optional opto-LINK cable. The optional opto-LINK cable can be used to transfer setup and calibration information from a PC (eg. to be stored for later use and/or transferred to other instruments). It can also be used to download software upgrades to the instrument from a PC.

The PC end of the opto-LINK cable is a standard female DB9 connector, or USB connector. The instrument end of the cable consists of an infrared transceiver, which attaches to the left side of the instrument display. To facilitate a quick and simple connection, the infrared transceiver is secured in place by a permanent magnet located within the head of the opto-LINK.

Refer to opto-LINK Activation page 23 for more information.

#### WARNING

The opto-LINK head contains a strong magnet and care should be taken with its proximity to electronic media (eg. credit cards, floppy disks, etc.) and/or other electronic instrumentation.



Figure 13: opto-LINK Attachment

### 3.11. Connecting Shields

To obtain full EMC or for RFI immunity, cable shields MUST be connected to the earth lug on the rear of the instrument.

Figure 14 illustrates an example of possible connections. Also shown are the connecting cables restrained using cable ties fastened around the cable strain relief anchors.

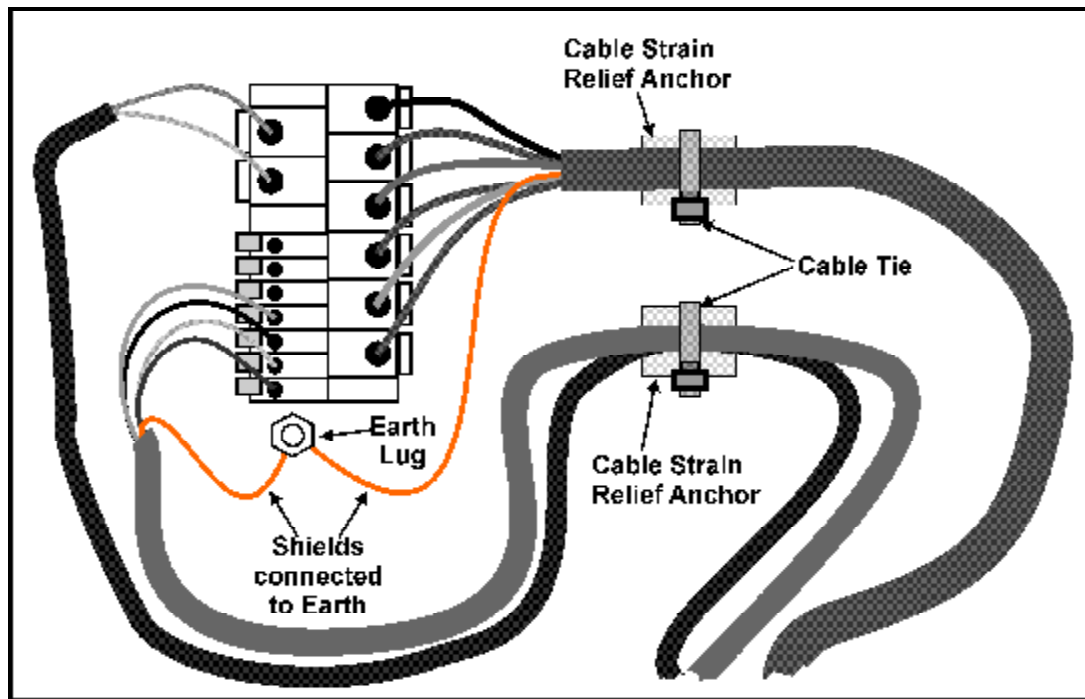

Figure 14: Cable Shield Connection

#### 3.11.1. Cable Shield Connection and Earthing

- Care should be taken when connecting shields to maximise EMC or RFI immunity and minimise earth loops and cross-talk (interference) between instruments.
- For full EMC or for RFI immunity, termination of the cable shields at the earth lug is very important. The earth lug of the instrument must be separately connected to ground potential via a reliable link.
- The instrument should only be connected to earth via a single reliable link to avoid earth loops.
- Where each instrument is separately earthed, interconnecting cable shields should be connected at one end only. This also applies to communications cable shields in Ring Networks, refer to Short Ring Network and Long Ring Network connections under 'RS-232 Serial' pages 12 and 13.
- **Caution:** Some load cells connect the cable shield directly to the load cell (and therefore the scale base). Connection of the load cell cable shield in this situation may be site specific.

### 3.12. Regulatory Sealing Requirements

To comply with regulatory sealing requirements for each instrument, (ie. to ensure instruments are not accidentally or deliberately tampered with), it is important that proper sealing procedures be adhered to. Refer to Appendix - Trade Sealing page 54 for more information.

## 4. Data Entry

Throughout the setup and normal weighing mode, different data entry methods are used. Each method is described below.

When using the keypad for normal operation, press the key on keypad to initiate the feature.

### 4.1. Editing Annunciators

When in Setup the instrument displays Editing Annunciators. Figure 15 identifies each of the editing annunciators. When in Setup, press the corresponding keypad key below the annunciator.

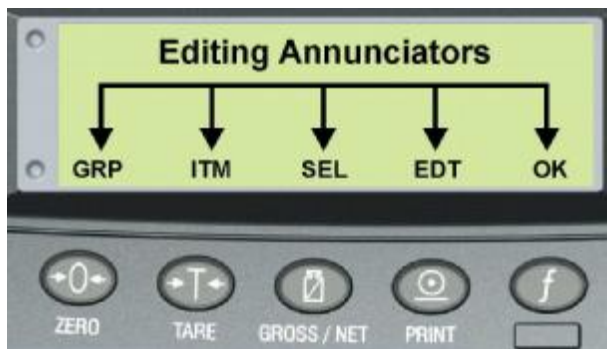

Figure 15: Editing Annunciators

Editing Annunciator	Key Name	Description
<b>GRP</b>	ZERO	Steps through the list of Groups.
<b>ITM</b>	TARE	Steps through the list of Items. Press this key to accept changes and return to the menus. (Also refer to the <b>OK</b> description below.)
<b>SEL</b>	GROSS/NET	Moves the editing cursor in some editing modes.
<b>EDT</b>	PRINT	Steps through the available options when editing a particular item.
<b>OK</b>	OK (FUNCTION)	Press this key to accept changes and return to the menus. (Also refer to the <b>ITM</b> description above.)

## 4.2. Numeric Entry

A numeric entry box allows the input of a number. When entering a number, the display will show digits with the currently selected digit flashing. The **<SEL>** key is pressed to select a digit to change. When the digit is selected the **<EDT>** key is pressed to change the digit from **0** through **9**. The left most digit can also be changed to a dash (-) to enter a negative number. The **<OK>** key is pressed to accept the number that has been entered and return to the menu item.

Upper and lower limits are placed on some entries and an entry outside this range will cause the instrument to display dashes (ie. - - - - -).

**Example:** When in Setup follow the steps below to set Build, Max Capacity.

Press <b>&lt;GRP&gt;</b> repeatedly to display the <b>BUILD</b> group.
Press <b>&lt;ITM&gt;</b> repeatedly to display the <b>CAP</b> item.
Press <b>&lt;SEL&gt;</b> to select <b>CAP</b> and display the current setting (eg. 0000.00kg).
The currently chosen digit will be flashing. Press <b>&lt;SEL&gt;</b> to advance to the next digit.
When the digit to edit is flashing, press <b>&lt;EDT&gt;</b> repeatedly to cycle from <b>0</b> through <b>9</b> .
When the new digit to be set is flashing either press <b>&lt;SEL&gt;</b> to move to the next digit to edit and repeat the previous step; or press <b>&lt;OK&gt;</b> or <b>&lt;ITM&gt;</b> to accept all of the displayed digits (including the flashing digit) and re-display the menu item name.

## 4.3. Selections and Options

A selection entry requires the choice of a single option from a list. When a Group and Item have been chosen, the **<SEL>** key is used to display the current setting for that item. The **<EDT>** key can be used to cycle through the options for that item. When the desired option is displayed the **<OK>** key can be pressed to accept the displayed option and re-display the item name.

**Example:** When in Setup follow the steps below to set Options, Filter.

Press <b>&lt;GRP&gt;</b> repeatedly to display the <b>OPTION</b> group.
Press <b>&lt;ITM&gt;</b> repeatedly to display the <b>FILTER</b> item.
Press <b>&lt;SEL&gt;</b> to select <b>FILTER</b> and display the current setting.
Press <b>&lt;EDT&gt;</b> to cycle through the options for that item.
Press <b>&lt;OK&gt;</b> or <b>&lt;ITM&gt;</b> to accept the displayed option and re-display the menu item name.

## 5. Basic Operation



Figure 16: Display and Controls Illustration

### 5.1. Display

<b>Weight Display</b>	The Weight Display indicates the weight readings, setup information, errors and warnings.		
<b>Units Display</b>	The Units Display shows the units of the weight reading as: grams (g), kilograms (kg), pounds (lb), tonnes (t) or none. If the instrument is set up for counting the units display will show pieces (p).		
<b>Annunciators</b>	<b>⇒0←</b>	<b>ZERO</b>	Visible when the gross reading is within $\pm \frac{1}{4}$ of a division of true zero.
	<b>NET</b>	<b>NET</b>	Visible when the displayed reading represents NET weight.
	<b>~</b>	<b>MOTION</b>	Visible when the displayed reading is not stable.
	<b>▲</b>	<b>OVER</b>	Visible when either of the setpoints is set as type OVER, and the weight is above the target weight.
	<b>▼</b>	<b>UNDER</b>	Visible when either of the setpoints is set as type UNDER, and the weight is below the target weight.
	<b>1</b>	<b>OUT 1</b>	Visible when Output 1 is turned ON.
	<b>2</b>	<b>OUT 2</b>	Visible when Output 2 is turned ON.
	<b>┌</b>	<b>ZERO BAND</b>	Visible when the displayed weight is within the zero 'dead' band setting. (The zero band symbol shows near the top right corner of the display.)
	<b>⏸</b>	<b>HOLD</b>	Visible when the displayed reading is held.
	<b>🔋</b>	<b>LOW BATTERY</b>	Visible when battery voltage is too low and batteries need replacing or recharging. (The low battery symbol shows in the top right corner of the display.)
When in Setup the editing annunciators are shown to identify the function of the front panel keys (ie. <b>GRP</b> , <b>ITM</b> , <b>SEL</b> , <b>EDT</b> and <b>OK</b> ). For more information refer to Editing Annunciators page 18.			

## 5.2. Has a key been locked?

A single press of each key triggers the weighing operation printed on it. The instrument allows individual keys to be disabled in the setup. All keys are enabled at the factory, but some keys may have been intentionally disabled (locked) during installation. If a key has been locked, a long beep sounds when it is pressed. If however, the key beeps normally, but does not appear to trigger the desired action, it is waiting for the weight reading to settle before the action can proceed.

## 5.3. Editing Function

Available during digital setup and calibration. This function is displayed using the editing annunciators above each key. Refer to Editing Annunciators page 18.

## 5.4. Stability – What is a “Stable Error”?

Once a <ZERO>, <TARE> or <PRINT> key is pressed the instrument waits for a stable valid reading before performing the associated operation. If the weight readings remain unstable or invalid due to some diagnostic error for longer than 10 seconds, the operation is cancelled and the **STABLE ERROR** message is displayed.

To improve the stability of the weight reading, increase the filtering or relax the motion detection criteria. Refer to **FILTER (Reading Average)** page 33 and **MOTION (Motion Detection)** page 33 for more information.

## 5.5. POWER Key

	<p>The &lt;POWER&gt; key is used to turn the instrument on and off. If the PWR.FN feature is set to UNITS, then a short press of the &lt;POWER&gt; key will switch units. To initially turn the instrument on, press and hold the &lt;POWER&gt; key. The display will show the following:</p> <ul style="list-style-type: none"> <li>• Display segments will light and then clear.</li> <li>• Software Version (eg. V1.0).</li> <li>• Calibration Counter (eg. C.00010). Refer to Calibration Counter page 25 for more information.</li> <li>• The current weight will then display.</li> </ul> <p>To turn the instrument off, press and hold the &lt;POWER&gt; key for three seconds. The instrument will display <b>OFF</b> followed by the 3s countdown.</p> <p><b>Battery Operation:</b> When using batteries the backlight will automatically turn off to conserve power after a short period of inactivity. A short press of the &lt;POWER&gt; key will turn the backlight on again. Refer to B.LIGHT (Backlight Operation) page 35 for more information.</p> <p><b>Unit Switching:</b> The &lt;POWER&gt; key will function as a unit switching button with a short press by configuring PWR.FN to UNITS.</p> <p><b>Locking:</b> The &lt;POWER&gt; key can be locked to prevent the instrument being turned off from the front keypad. Refer to KEY.LOC (Front Panel Key Locking) page 35 for more information.</p>
<p><b>Automatic Operation</b></p>	<p>The &lt;POWER&gt; key has a memory function associated with it. This means that the state of the auto out setting is remembered even if external power is interrupted. It is therefore possible to turn the instrument on in the safe knowledge that it will operate whenever external power is available and will not need to be manually turned on again if the power is interrupted.</p>

## 5.6. ZERO Key

	<p>When an empty scale has drifted away from a true zero reading, this key is used to perform a zero adjustment on the scale display. The zero adjustment is stored when power is removed and is re-used when next powered up.</p> <p>The amount of weight that may be cancelled by the <b>&lt;ZERO&gt;</b> key is limited via an item in the Setup of the instrument. Refer to Z.RANGE (Allowable Zero Operating Range) ⊗ page 33 for more information.</p> <p><b>Long Press:</b> When the indicator is set to Industrial mode a long press of the <b>&lt;ZERO&gt;</b> key will remove any stored zero adjustment. Refer to Industrial vs OIML and NTEP Modes page 25 for more information on modes.</p>
---	---

## 5.7. TARE Key

	<p>This key is used to temporarily set the scale to zero (such as cancelling the weight of a carton before performing a filling operation). The display will show the Net weight and the NET annunciator will be lit.</p> <p>The <b>&lt;TARE&gt;</b> key can operate in all modes (ie. Industrial, NSC, OIML and NTEP). Refer to Industrial vs OIML and NTEP Modes page 25 for more information.</p> <p>The weight tared is deducted from the allowable range of the scale, reducing the maximum weight that can be displayed.</p> <p>The tare adjustment is stored when power is removed and is re-used when next powered up.</p>
Preset Tare	<p>This feature allows the operator to manually enter the tare weight. When a preset tare weight is being used the instrument will display <b>Pt</b> before displaying the net weight.</p> <p>Any printing of the tare weight will be followed by the letters <b>Pt</b> if a preset tare value is active.</p> <p>A long press of the <b>&lt;TARE&gt;</b> key will allow editing of the Preset Tare value. Press the <b>&lt;OK&gt;</b> key to enter the Preset Tare setting. Change the Preset Tare setting using the <b>&lt;SEL&gt;</b> and <b>&lt;EDT&gt;</b> keys.</p> <p>The Preset Tare setting can be cleared by one of two means:</p> <ul style="list-style-type: none"> <li>• Using a long press of the <b>&lt;TARE&gt;</b> key and editing the preset tare value to zero.</li> <li>• While the gross load is zero;</li> <li>• Using a short press of the <b>&lt;TARE&gt;</b> key to retare the instrument in the usual manner.</li> <li>• OR, Using a short press of the <b>&lt;ZERO&gt;</b> key to zero the instrument in the usual manner.</li> </ul> <p>The tare adjustment is stored when power is removed and is re-used when next powered up.</p>



## 5.8. GROSS/NET Key

 <p><b>GROSS/NET</b></p>	<p>This key toggles the weight display between the Gross weight and the Net weight (provided that a Tare has previously been acquired using the &lt;TARE&gt; key).</p>
<p>opto-LINK Activation</p>	<p>This feature is used to temporarily connect a PC to the instrument for calibration and setup purposes.</p> <p>A long press of the &lt;GROSS/NET&gt; key will toggle the opto-LINK infrared communications On/Off.</p> <p>When the opto-LINK has been enabled the following will occur:</p> <ul style="list-style-type: none"> <li>• The instrument briefly displays the prompt <b>opto-L</b>.</li> <li>• The editing annunciators (ie. GRP, ITM, etc.) will flash for up to five minutes while the instrument searches for activity. During this period, the instrument also disables the RS-232 communications.</li> <li>• After a 5 minute period of no activity, the opto-LINK is disabled and the editing annunciators will stop flashing. The instrument will revert back to the normal RS232 (ie. the SERIAL:TYPE setting will be re-activated).</li> </ul>

## 5.9. PRINT Key

 <p><b>PRINT</b></p>	<p>If a printer or computer has been attached to the instrument and the manual print function has been selected, the &lt;PRINT&gt; key will trigger an output of the current weight reading. The <b>PRINT</b> prompt is displayed while waiting for the printer to accept data. If the printer is offline the <b>PRINT</b> prompt will remain for a maximum of 10 seconds before the operation is cancelled. Each weight printed is automatically added to an internal Total Weight.</p> <p><b>Long Press:</b> A long press of the &lt;PRINT&gt; key will print the total. The total weight is then cleared automatically.</p>
--	--

## 5.10. FUNCTION Key

 <p><b>Hold (K34*)</b></p>	<p>Use this key to perform hold.</p>
 <p><b>K35*</b></p>	<p>The function of this key can be selected from a number of different functions including peak-hold, counting, etc. Refer to Special Functions page 51 for details of the available functions. Each has an associated overlay sticker that should be applied to the &lt;FUNCTION&gt; key.</p> <p><b>Long Press:</b> A long press of the &lt;FUNCTION&gt; key may be used for certain functions depending on the primary function of the key.</p>

## 6. Configuration

### 6.1. General Setup Information

Configuration and calibration can be performed entirely from the front panel, using the digital setup facility. When **Full Setup** is used, all menu items are accessible and care must be taken to ensure no accidental changes are made to calibration and trade settings. In addition, there is also **Safe Setup** that provides restricted access. This setup method ensures that only settings that are not calibration or trade sensitive can be changed.

Full and Safe Setup can be passcode protected to prevent unauthorised or accidental tampering. If the scale has been passcode protected, the setup menus cannot be accessed until the correct code has been entered.

### 6.2. Basic Weighing Terminology

The following terms are used throughout the setup procedure. Knowledge of these basic weighing terms is beneficial in setting up and calibrating the instrument.

**Note:** Descriptions of these and other terms used in this manual are listed in the Glossary Terms page 67.

Term	Definition
Units	Units of measurement (kilograms, tonnes, pounds, etc.).
Full Scale	Total change in weight between zero gross load and full capacity gross load.
Resolution or Count-by	Smallest change in weight units that the display can show.
Total Number of Graduations	Maximum number of display steps between zero gross load and full capacity gross load. It is equal to full scale divided by the count-by.
Division	A single graduation.

#### Example

This example provides a check to ensure the capability of an indicator to read a stable weight on extremely small divisions compared to the load cell capacities.

The check is to find out what the microvolt per division is and then compare this to the manufacturer's specification. If the manufacturer's specification is smaller than the calculated value, the unit is within the requirements of operation.

**Note:** The capability of an indicator may be different than the trade approval limit of the micro-Volt per division.

A 10,000kg 2.0mV/V load cell is used in an application requiring a 5000kg full scale, with weight displayed in 5kg increments.

The values are:

- Units = kg
- Full Scale = 5000
- Count-by = 5

Calculating the total number of graduations:	$\text{Total Number of Graduations} = \frac{\text{Full Scale}}{\text{Count-by}} = \frac{5000}{5} = 1000 \text{ divisions}$
--	--

Signal voltages can be calculated as follows:	
Calculating the full scale signal (load cell):	$\text{Full Scale Signal} = \frac{\text{Full Scale Load Cell}}{\text{Capacity}} = \frac{5000}{10000} \times 2.0\text{mV/V} = 1.0\text{mV/V}$
Since the instrument uses 5V load cell excitation, the absolute signal voltage is:	$\text{Absolute Signal Voltage} = \text{Excitation Voltage} \times \text{Full Scale Signal} = 5\text{V} \times 1.0\text{mV/V} = 5.0\text{mV}$
Calculating the signal resolution:	$\text{Signal Resolution} = \frac{\text{Absolute Signal Voltage}}{\text{Number of Graduations}} = \frac{5.0\text{mV}}{1000 \text{ divisions}} = 0.005\text{mV / division} = 5\mu\text{V / division}$

### 6.3. Filtering Techniques

There is a trade off between noise filtering and the step-response time of the system. The step-response is defined as the time between placing a weight on the scale and the correct stable weight reading being displayed. This does not affect the number of readings per second that are taken. It simply defines the amount of time that is required to determine a final weight reading.

The **FILTER** setting in the instrument setup shows the amount of time over which the averaging is taken. Increasing the averaging time will result in a more stable reading but will extend the time it takes the instrument to settle to a final reading. Refer to **FILTER (Reading Average)** page 33.

### 6.4. Industrial vs OIML and NTEP Modes

Instruments may be operated in Industrial, OIML, or NTEP modes depending on the application firmware. The OIML, and NTEP modes restrict certain aspects of the operation of the instrument to ensure compliance with the respective trade certified standards. For more information refer to the Calibration Counter section below and also to the USE

(Scale Use) Å section page 33 for setup information. The following table lists the operation differences for each of these modes.

Element	Industrial	OIML	NTEP
<b>Underload</b>	–105% of full scale	–1% or –2% of full scale depending on zero range setting	–1% or –2% of full scale depending on zero range setting
<b>Overload</b>	105% of full scale	Full scale +9 divisions	105% of full scale
<b>Tare</b>	No restrictions on Tare	Tare values must be > 0	Tare values must be > 0 and rounded to the nearest graduation
<b>Test Modes</b>	Unlimited time allowed	Limited to five seconds	Limited to five seconds

**Table 1: Industrial vs OIML and NTEP Modes**

### 6.5. Calibration Counter

Within the setup there are a number of critical steps that can affect the calibration and/or legal for trade performance of the instrument. If any of these steps are altered, the trade certification of the scale could be voided.

The instrument provides built-in calibration counter(s) to monitor the number of times the critical steps are altered. The value of the counter(s) is stored within the instrument and can only be reset at the factory. Each time a critical step is altered, the counter(s) will increase by one. Whenever the

instrument is powered up, or setup mode is entered/exited, the current value in the counter(s) is displayed briefly (eg. C00010).

Industrial	OIML	NTEP
<p>The <b>Calibration Counter</b> increments when trade critical settings, marked with <b>Ä</b>, are changed. An example of the counter is <b>C.00019</b>.</p>	<p>The <b>Calibration Counter</b> increments when trade critical settings, marked with <b>Ä</b>, are changed. An example of the counter is <b>C.00019</b></p>	<p>The <b>Calibration Counter</b> increments when trade critical settings in the Calibration (<b>CAL</b>) menu, marked with <b>Ä</b>, are changed. An example of the counter is <b>C.00010</b>.</p> <p>The <b>Configuration Counter</b> increments when other trade critical settings (ie. <b>not</b> in the <b>CAL</b> menu), marked with <b>Ä</b>, are changed. An example of the counter is <b>F.00009</b>.</p>

The value(s) of the counter(s) is written on the tamperproof trade label on the front or top of the indicator for trade-certified applications and functions as an electronic seal. If any legal for trade settings are changed on the instrument, the current value of the calibration counter(s) will be different from the recorded value and the seal is broken. In this manual, items marked with **Ä** indicate that the setting is legal for trade critical settings.

## 6.6. Passcodes

The instrument has two levels of passcodes to provide a security lock on accessing Setup via the keypad.

- Full Setup Passcode
- Safe Setup Passcode

The Full Setup passcode can also be used to access Safe Setup.

### 6.6.1. Full Setup Passcode

Setting a passcode for Full Setup restricts any access to Full Setup. Refer to FULL.PC (Full Security Passcode for Digital Setup) page 34.

### 6.6.2. Safe Setup Passcode

Setting a passcode for Safe Setup restricts access to Safe Setup functions. Refer to SAFE.PC

(Safe Security Passcode for Digital Setup) page 34.

### 6.6.3. Setup Lock-Out

If an attempt is made to enter Full or Safe Setup using an incorrect passcode, the instrument will respond with the message **ENTRY DENIED** and then the user will be returned to normal operating mode. A passcode counter has been set so that only three failed attempts can be made to access Full/Safe Setup. On the fourth attempt the user will be 'locked out' of

Full/Safe setup. Should this occur the **ENTER PASS** prompt will not display, but instead the **ENTRY DENIED** message displays and returns the user to the normal operating mode. To rectify this issue the instrument must be turned off. When the instrument is turned back on the passcode counter is reset to zero (allowing the user to enter the correct passcode).

## 7. Calibration

The calibration of the indicator is fully digital. The calibration results are stored in permanent memory for use each time the instrument is powered up.

**Note: Some of the digital setup steps can affect calibration. The BUILD and OPTION settings MUST be configured before calibration is attempted.**

To perform a calibration, when in Full Setup select the **CAL** Group using the **<GRP>** key.

The calibration programme will automatically prevent the instrument from being calibrated into an application outside of its specification. If an attempt is made to calibrate outside of the permitted range, an error message will display and the calibration will be abandoned. Refer to Error Messages page 61.

The instrument has a wide-range A/D converter. The industrial calibration range of the instrument extends well beyond the Trade approved range.

**Note: It should not be assumed that just because the instrument has successfully calibrated a scale, that the scale is correct for trade use. Always check the scale build against the approval specification.**

### 7.1. Performing a Digital Calibration with Test Weights

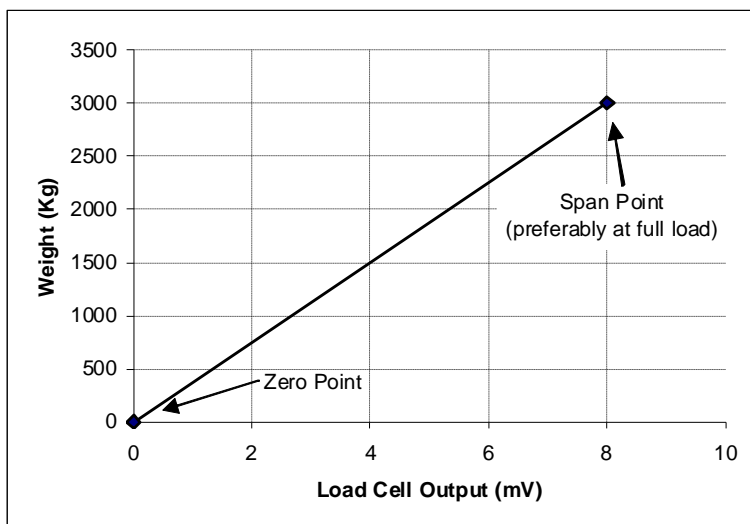

**Figure 17: Chart - Zero and Span Points to Interpolate Weight from Load Cell**

The Zero setting (CAL:ZERO) specifies a gross zero point for the scale. The Span setting (CAL:SPAN) specifies a second point (**preferably close to full scale**) used to convert the A/D readings into weighing units (eg. kg). Select either of the Zero (CAL:ZERO) or Span (CAL:SPAN) calibration items. It is important that an initial Zero calibration is performed before any SPAN calibrations. The chart shown here demonstrates how the zero and span points are used to interpolate a weight reading from the load cell reading.

**Note: Calibration points (Zero, Span and Linearisation) must be spaced by at least 2% of Full scale from each other.**

### 7.1.1. ZERO (Zero Calibration Routine)

Press the <b>&lt;SEL&gt;</b> key to start. The display will show the current weight. Remove all weight from the scale structure.
Press <b>&lt;SEL&gt;</b> , <b>&lt;EDT&gt;</b> or <b>&lt;OK&gt;</b> to execute a Zero Calibration. The display will show <b>Z.in.P</b> to indicate that zeroing is in progress. When the process is complete the display will return to weight to allow the zero to be checked.
Press the <b>&lt;ITM&gt;</b> key to leave the Zeroing routine or press <b>&lt;SEL&gt;</b> , <b>&lt;EDT&gt;</b> or <b>&lt;OK&gt;</b> to repeat the operation.

### 7.1.2. SPAN (Span Calibration Routine)

Press <b>&lt;SEL&gt;</b> or <b>&lt;OK&gt;</b> to start. The display will show the current weight.
Use <b>&lt;EDT&gt;</b> to select whether the linearisation points need clearing <b>CLr.L y</b> , or not <b>CLr.L n</b> . Press <b>&lt;OK&gt;</b> to continue.
Add the calibration test mass to the scale. The minimum acceptable span calibration weight is 2% of the scale range. A weight this small may limit calibration accuracy. The closer the test weight is to full scale the better the accuracy.
Press <b>&lt;SEL&gt;</b> or <b>&lt;OK&gt;</b> to show the calibration weight value. Change this to the correct calibration weight using the <b>&lt;SEL&gt;</b> and <b>&lt;EDT&gt;</b> keys.
Press <b>&lt;ITM&gt;</b> or <b>&lt;OK&gt;</b> to trigger the Span Calibration routine. The display will show <b>S.in P</b> to indicate that spanning is in progress. When the process is complete the display will return to weight to allow the new weight reading to be checked.
When the Span Calibration is complete, press the <b>&lt;ITM&gt;</b> key to leave the Spanning routine or press <b>&lt;SEL&gt;</b> , <b>&lt;EDT&gt;</b> or <b>&lt;OK&gt;</b> to re-edit the calibration weight and repeat the operation.

## 7.2. Performing a Calibration with Direct mV/V Entry

In applications where test weights are not easily available, it is possible to calibrate the instrument directly by entering the mV/V signal strength at Zero and full scale Span. The Direct Zero setting (CAL:DIR.ZER) specifies a gross zero point for the scale. The Direct Span setting (CAL:DIR.SPN) specifies the mV/V signal strength corresponding to an applied mass equal to the full scale reading. This calibration technique is not compatible with linearisation. Clearly the accuracy of this type of calibration is limited to the accuracy of the direct mV/V data.

### 7.2.1. DIR.ZER (Direct Zero Calibration Entry)

Press the <b>&lt;OK&gt;</b> key to start. The display will show the current weight.
Press the <b>&lt;OK&gt;</b> key to enter the Direct Zero setting. Change the mV/V setting to the correct value for <b>Zero</b> using the <b>&lt;SEL&gt;</b> and <b>&lt;EDT&gt;</b> keys.
Press the <b>&lt;OK&gt;</b> key to store the new zero calibration. When the process is complete the display will return to weight to allow the new weight reading to be checked.
Press the <b>&lt;ITM&gt;</b> key to leave the Direct Zero routine or <b>&lt;OK&gt;</b> to repeat the operation.

### 7.2.2. DIR.SPN (Direct Span Calibration Entry)

Press the <b>&lt;OK&gt;</b> key to start. The display will show the current weight.
Press the <b>&lt;OK&gt;</b> key to enter the Direct Span setting. Change the mV/V setting to the correct value for the full scale signal strength, using the <b>&lt;SEL&gt;</b> and <b>&lt;EDT&gt;</b> keys.
Press the <b>&lt;OK&gt;</b> key to store the new span calibration. When the process is complete the display will return to weight to allow the new weight reading to be checked.
Press the <b>&lt;ITM&gt;</b> key to leave the Direct Span routine or <b>&lt;OK&gt;</b> to repeat the operation.

## 8. Setup

The instrument digital setup facilities provide the means to configure and calibrate the instrument.

### 8.1. Accessing Setup

There are two methods to access the Setup area. For further details of menu items available in each setup mode, refer to the Setup Menu Quick Reference page 59.

#### 8.1.1. Access using Full Setup

The **Full Setup** method provides access to all functions in Setup, including legal for trade and calibration sensitive settings. Changes in Full Setup mode may result in the calibration counter being incremented. Items marked with  $\ddot{A}$  indicate that the setting is trade critical. Changes to passcodes and restoring the factory default settings can only be accessed in Full Setup mode. These items will however not increment the calibration counter. If an attempt is made to enter Full Setup using the incorrect passcode, the instrument will respond with the message **ENTRY DENIED**. Refer to Passcodes page 26 for more information.

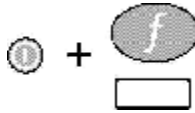
Full Setup

<ol style="list-style-type: none"> <li>1. Instrument on.</li> <li>2. Press and hold both the <b>&lt;POWER&gt;</b> and <b>&lt;FUNCTION&gt;</b> keys together for two seconds.</li> <li>3. <b>Full Setup</b> can also be entered by pressing a push-button accessed from the rear of the instrument. Refer to OPTIONS:R.ENTRY page 33 for more details.</li> </ol>
<p><b>WARNING</b></p> <p>All items in all menus will be enabled in <b>Full Setup</b>. Care should be taken to avoid inadvertently altering the Build or Calibration settings.</p>

#### 8.1.2. Access using Safe Setup

The **Safe Setup** method restricts access to the Trade Critical settings. Changes made in this mode will not increment the calibration counter. In this manual, items marked with  $\ddot{A}$  indicate that the setting is trade critical. If an attempt is made to enter Safe Setup using the incorrect passcode, or if an attempt is made to alter a trade critical setting while in Safe Setup, the instrument will respond with the message **ENTRY DENIED**. Refer to Passcodes page 26 for more information.

Safe Setup

<ol style="list-style-type: none"> <li>1. Instrument on.</li> <li>2. Press and hold both the <b>&lt;POWER&gt;</b> and <b>&lt;ZERO&gt;</b> keys together for two seconds.</li> </ol>

### 8.1.3. Setup Display Prompts

When accessing **Full** or **Safe Setup** the instrument will beep twice and then display the following:

- FULL or SAFE (depending on setup access type)
- SETUP
- Software Version (eg. V1.0)
- Calibration Counter (eg. C.00010). Refer to Calibration Counter page 25 for more information.
- If a passcode has been configured, the **ENTER PASS** prompt will display and the setup passcode must be entered to gain access. Refer to Passcodes page 26, SAFE.PC (Safe Security Passcode for Digital Setup) page 34 and FULL.PC (Full Security Passcode for Digital Setup) page 34 for more information.
- The title of the first Group (ie. **BUILD**) will then be displayed.

### 8.2. Exiting Full or Safe Setup

To save settings, exit setup and return to the normal weighing mode use one of the following methods:

<b>Option 1</b>	Press and hold both the <b>&lt;POWER&gt;</b> and <b>&lt;FUNCTION&gt;</b> keys together for two seconds.
<b>Option 2</b>	Press and hold both the <b>&lt;POWER&gt;</b> and <b>&lt;ZERO&gt;</b> keys together for two seconds.
<b>Option 3</b>	Press the <b>&lt;GRP&gt;</b> key repeatedly. When <b>- End -</b> displays press <b>&lt;ITM&gt;</b> or <b>&lt;OK&gt;</b> .

The instrument will beep and then display:

- SAVING
- Software Version (eg. V1.0)
- Calibration Counter (eg. C.00010). Refer to Calibration Counter page 25 for more information ("R" series instruments only).
- The current weight will then display.

**Warning:** If the power is interrupted while in setup (ie. by disconnecting the power cable or pressing the **<POWER>** key), unsaved settings will be lost.

### 8.3. Groups and Items

All keypad setup options are organised in a tree structure made up of **Groups** and **Items** – the following notation will be used (GROUP:ITEM). Refer to Setup Menu Quick Reference page 59 for a list of all Groups and Items.

GRP (Group)	Setup is divided into a series of <b>Groups</b> . Each group has a distinctive group title. All options in any one group have related functions. The <b>&lt;GRP&gt;</b> key can be used to cycle through the available groups.
ITM (Item)	Each group is divided into individual <b>Items</b> . Each item represents a parameter that can be changed. Pressing the <b>&lt;ITM&gt;</b> key will enter the displayed group, allowing access to the items within the group. The <b>&lt;ITM&gt;</b> key can be used to cycle through the available items. The <b>&lt;SEL&gt;</b> key is then used to edit the item

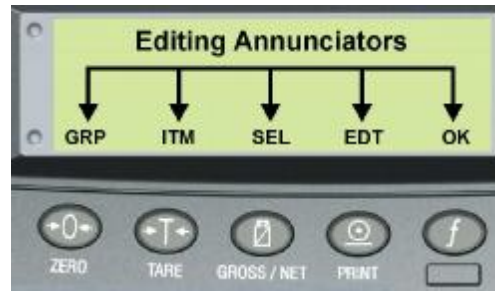

## 8.4. Setup Menus

### 8.4.1. BUILD (Scale Build)

Settings within this Group are used to configure the indicator to suit the current application. It is important to fully set the options within this group before calibration is attempted. Later changes to items within this group may invalidate the current calibration data.

<b>DP</b> <b>(Decimal Point Position)</b> Ä	Sets the location of the decimal point on the display. To avoid confusion, set this parameter first so that all other weight related values are displayed with the decimal point in the correct position.  Can be set from 000000 (none) to 0.00000  Default: 000000
<b>CAP</b> <b>(Maximum Capacity)</b> Ä	Sets the nominal maximum capacity (or full scale) of the scale. This is set in weighing units (eg. kg, t, etc.), with the decimal point in place. For example, if a scale is to weigh 500.0 kg in 0.5 kg increments, CAP is set to 500.0, and RES is set to 5.  Range: 000100 to 999999  Default: 003000
<b>RES</b> <b>(Count-by Resolution)</b> Ä	Sets the resolution (or Count-by) of the display. The resolution is the number by which the indicator will count.  Options are: 1, 2, 5, 10, 20, 50 or 100  Default: 1
<b>UNITS (Weighed Units)</b> Ä	Sets the units for display and printing.  Options are: (g) grams, (kg) kilograms, (lb) pounds, (t) tonnes, ( ) none (ie. other units).  Default: kg (K303 Default: lb)
<b>HI.RES</b> <b>(High Resolution x 10 mode)</b> Ä	Sets the instrument to display weight at 10 times resolution. This is intended for test purposes in trade applications but may be used for industrial weighing. This mode is indicated by the flashing of the units annunciator.  Options are: ON or OFF  Default: OFF
<b>CABLE</b> <b>(4-Wire or 6-Wire)</b> Ä	Sets the load cell input to operate in 4-wire (auto sense) or 6-wire mode.  Options are: 4 or 6  Default: 6

### 8.4.2. OPTION (Scale Options)

Items within this Group are used to configure the operating parameters of the scale.

<b>USE</b> <b>(Scale Use) Ä</b>	<p>This is where the basic use of the scale is set. This setting configures the instrument for Industrial, OIML, or NTEP operation. Refer to Industrial vs OIML and NTEP Mode page 25 for more information.</p> <p>Default: INDUST</p>
<b>FILTER</b> <b>(Reading Average)</b>	<p>The instrument can average a number of consecutive readings when calculating the displayed weight. This is used to dampen unwanted weight fluctuations caused by vibrations or dynamic forces. High settings will stabilise the display at the expense of rapid response to sudden weight changes.</p> <p>Options are: NONE, 0.2, 0.5, 1.0, 2.0, 3.0, 4.0 (time in seconds)</p> <p>Default: 0.5 (seconds)</p>
<b>MOTION</b> <b>(Motion Detection) Ä</b>	<p>Sets how much weight variation over a defined time period is allowed before the displayed weight is deemed to be unstable. This value is displayed as weight change (0.5 or 1.0 graduations) per second. When set to <b>OFF</b>, the Motion Detection is ignored and ZERO, TARE and PRINT actions are instantaneous.</p> <p>Options: OFF, 0.5-1.0, 1.0-1.0, 3.0-1.0, 0.5-0.5, 1.0-0.5, 3.0-0.5 (graduations per second)</p> <p>Default: 0.5-1.0 (0.5 graduations per second)</p>
<b>INIT.Z</b> <b>(Initial-Zero on Startup)</b>	<p>This function can be used to automatically ZERO the indicator during power-up. The amount of weight that can be zeroed is limited to +/- 10% of full scale.</p> <p>Options are: ON or OFF</p> <p>Default: OFF</p>
<b>Z.TRAC</b> <b>(Zero Tracking Sensitivity) Ä</b>	<p>Zero tracking allows the display to adjust for minor changes in the zero balance of the scale. When enabled, the instrument will track weight readings within the zero 'dead' band back to exactly zero at a maximum rate of 0.5 (SLOW), 3 (MED) or 10 (FAST) graduations per second.</p> <p>Options are: OFF, SLOW, MED, FAST</p> <p>Default: OFF</p>
<b>Z.RANGE</b> <b>(Allowable Zero Operating Range) Ä</b>	<p>This setting restricts the range over which the Zero functions can operate.</p> <p>Options are: -2_ 2, -1_ 3, -20_20, FULL</p> <p>Default: -2_ 2 (-2% to +2%)</p>
<b>Z.BAND</b> <b>(Zero 'Dead' Band) Ä</b>	<p>This is an adjustable margin either side of true zero that defines the zero 'dead' band. The zero 'dead' band is used by the automated functions to determine zero load (eg. a setting of 4 specifies that readings between -4.5 and 4.5 are considered to be zero).</p> <p>When the displayed weight reading is within this band the instrument displays the <b>zero band</b> annunciator. Refer to 5.1Display page 20.</p> <p>Settable over the full weight range. Always enter a number in multiples of display units. Refer to RES (Count-by Resolution) Ä page 32 for more information.</p> <p>Default: 0 (ie. -0.5 to 0.5 graduations)</p>
<b>R.ENTRY</b> <b>(Entry Means)</b>	<p>This setting can be used to restrict access to the full setup. The first entry to the full setup menu using the push button on the rear of the instrument causes all future access to the full setup to be restricted to the push button.</p>

<b>to Full Setup)</b>	Options are: OFF, ON Default: OFF
-----------------------	--------------------------------------

### 8.4.3. CAL (Scale Calibration)

Items within this group perform various calibration routines. Certain items in the Scale Build can affect the calibration of the scale. Always check that these sections are correctly configured to suit the current application before attempting to calibrate the scale.

<b>ZERO (Zero Calibration) Ä</b>	Select to perform Zero Calibration. While the zeroing is in progress the display will show <b>Z.in P.</b>
<b>SPAN (Span Calibration) Ä</b>	Select to perform Span Calibration. While the span calculation is in progress the display will show <b>S.in P.</b>
<b>DIR.ZER (Direct Zero Calibration) Ä</b>	Select to enter the mV/V value of the zero calibration directly. This feature is used to enable approximate calibrations to be performed in situations where a standard ZERO calibration is impractical (eg. calibration on a partially filled silo).
<b>DIR.SPAN (Direct Span Calibration) Ä</b>	Select to enter the mV/V value of the full scale capacity of the scale build. This feature enables the instrument to be calibrated based on the rated output capacity of the load cells rather than using test weights. The accuracy of this method is limited to the accuracy of the published load cell ratings.
<b>FAC.CAL (Restore Default Factory Calibration) Ä</b>	Select this choice to restore default factory calibration. This restores all calibration critical settings in the <b>BUILD</b> , <b>OPTION</b> and <b>CAL</b> menus back to factory defaults. The instrument will prompt with <b>Cont. N.</b> Press <b>&lt;EDT&gt;</b> to change to <b>Cont. Y</b> and <b>&lt;OK&gt;</b> to continue. If <b>Cont. Y</b> is chosen and then <b>&lt;OK&gt;</b> or <b>&lt;ITM&gt;</b> is pressed, the instrument will display <b>DONE</b> to indicate that the operation has been completed.

### 8.4.4. SPEC (Special Settings Menu)

Settings within this group control features including passcodes, key locking, key functions and display settings.

<b>SAFE.PC (Safe Security Passcode for Digital Setup)</b>	The <b>SAFE.PC</b> (Safe Passcode) allows partial access to Digital Setup (ie. only non calibration/trade critical settings can be changed). For the Safe Passcode to have any effect, the <b>FULL.PC</b> passcode must also be set. The default passcode setting is <b>000000</b> that allows free access. Any other number will enable the passcode functions and restrict access. Refer to Passcodes page 26 and Accessing Setup page 30 for more information.  Range 000000 to 999999 Default: 000000
<b>FULL.PC (Full Security Passcode for)</b>	The <b>FULL.PC</b> (Full Passcode) can be set to restrict access to Full Digital Setup. This passcode is used to prevent unauthorised or accidental tampering in the instrument setup. The default passcode setting is <b>000000</b> that allows free access. Any other number will enable the passcode functions and restrict

<b>Digital Setup)</b>	<p>access. Refer to Passcodes page 26 and Accessing Setup page 30 for more information.</p> <p>Range 000000 to 999999</p> <p>Default: 000000</p> <p>It is important to note that when restricting Full access to Setup the passcode must not be forgotten.</p> <p>It is only possible to circumvent the passcode at the factory.</p> <p>Care must be taken when setting the Full Digital Setup Passcode to ensure that the instrument does not become permanently locked.</p>															
<b>KEY.LOC (Front Panel Key Locking)</b>	<p>This item allows individual keys to be locked and unlocked.</p> <ul style="list-style-type: none"> <li>- The display shows a dash (–) to indicate that a key is locked (inactive) or characters for each key that is active (ie. the characters <b>P12345</b> display).</li> <li>- The letter <b>P</b> represents the <b>&lt;POWER&gt;</b> key while the numbers <b>1234</b> and <b>5</b> represent the remaining operation keys.</li> <li>- The operation keys are numbered from the left with the <b>&lt;ZERO&gt;</b> key being number <b>1</b>.</li> </ul> <p><b>Note:</b> When the <b>&lt;POWER&gt;</b> key is locked, the instrument cannot be turned off from the front keypad.</p> <p>Default: P12345 - All keys are unlocked (active)</p>															
<b>KEY.FN (Key Functions) K35*</b>	<p>The function of the keypad <b>&lt;FUNCTION&gt;</b> key can be selected here. Refer to Special Functions page 51 for details of the available key functions.</p> <p>Options are:</p> <table border="1" data-bbox="411 1099 1313 1256"> <tr> <td>NONE</td> <td>TEST</td> <td>COUNT</td> <td>UNITS</td> <td>HOLD</td> </tr> <tr> <td>PEAK.H</td> <td>SHOW.T</td> <td>HI.RES</td> <td>A.TARE</td> <td></td> </tr> <tr> <td colspan="2">SET.PT (only K356)</td> <td></td> <td></td> <td></td> </tr> </table> <p>Default: NONE</p>	NONE	TEST	COUNT	UNITS	HOLD	PEAK.H	SHOW.T	HI.RES	A.TARE		SET.PT (only K356)				
NONE	TEST	COUNT	UNITS	HOLD												
PEAK.H	SHOW.T	HI.RES	A.TARE													
SET.PT (only K356)																
<b>AUT.OFF (Auto Power Off / Battery Operation)</b>	<p>The instrument can be set up to automatically power down after a period of no activity. Weight motion, network communications or any press of the keyboard is enough to keep the instrument powered on. When operating on batteries the instrument will turn off after 30 minutes of inactivity even if set to Auto.</p> <p>Options are:</p> <p>NEVER: Never power off automatically, 1, 5, 10, 30, Auto (time in minutes)</p> <p>Default: Auto</p>															
<b>B.LIGHT (Backlight Operation)</b>	<p>Sets the operation of the backlight. When operating the backlight with batteries the brightness is lowered automatically to conserve power and the backlight will automatically turn off after 10 seconds of inactivity. To turn on again, press the <b>&lt;POWER&gt;</b> key.</p> <p>Options are:</p> <p>OFF: Backlight is off.</p> <p>ON: Backlight is on when weight motion, network communications or any keypress is detected.</p> <p>FORCED: Backlight is permanently on.</p> <p>Default: ON</p>															

<p><b>REM.FN</b> <b>(Remote Function)</b> <b>K344, K35*</b></p>	<p>This item allows the indicator to be triggered from a remote input (see section 3.9.2 Remote Input). The remote input can be set to have:</p> <ul style="list-style-type: none"> <li>- no function (ie. NONE) or</li> <li>- it can be set to mimic one of the front five panel key functions (ie. where KEY1=ZERO, KEY2=TARE, KEY3=GROSS/NET, KEY4=PRINT and KEY5=FUNCTION).</li> </ul> <p>The remote input can also be set to BLANK where, when the remote input is pressed and held, the indicator displays dashes (ie. - - - - -) and the front five key functions are disabled. When the remote input is released the indicator display and front key functions return to normal.</p> <p><b>For the REM.FN to have effect, the SERIAL:TYPE item must be set to AUTO.</b></p> <p>Options are:</p> <p>NONE: No function.</p> <p>KEY1 to KEY 5: Mimic one of the front five function keys</p> <p>BLANK: Display dashes (ie. - - - - -) and disable front key functions.</p> <p>Default: NONE</p>																
<p><b>REM.CHR</b> <b>(Remote Input Transmit Idle Character)</b> <b>K344, K35*</b></p>	<p>The remote input transmit idle character specifies the character to be transmitted whilst the serial transmitter is idle, regardless of the state of the DTR line. This character is only transmitted when a remote function (SPEC:REM.FN) is enabled, and serial port type (SERIAL:TYPE) is set to PRINT or AUTO.PR. This function allows the remote input to function even when a printer is connected. This character must be chosen so it is ignored by the printer. Typically the ENQ (ASCII 05) character is suitable.</p> <p>Range 000 to 255</p> <p>Default: 005</p>																
<p><b>BAT.VLT</b> <b>(Battery Voltage)</b></p>	<p>Default: 4.8V</p> <p>A low battery annunciator will be displayed at 10% above low battery level. The indicator will assume it is on battery power when its input voltage is less than twice the low battery level for the selected battery voltage. In the PWR mode the indicator will always assume it has external power. Correct function of the low battery warning is dependent on correct setting of the battery voltage.</p> <table border="1" data-bbox="564 1458 1358 1868"> <thead> <tr> <th>Battery Voltage</th> <th>Low Battery Level</th> </tr> </thead> <tbody> <tr> <td>4.8V</td> <td>4V</td> </tr> <tr> <td>7.2V</td> <td>6V</td> </tr> <tr> <td>9.6V</td> <td>8V</td> </tr> <tr> <td>12V</td> <td>10V</td> </tr> <tr> <td>24V</td> <td>20V</td> </tr> <tr> <td>PWR</td> <td>NO BATTERY</td> </tr> <tr> <td>Li-Ion</td> <td>12V</td> </tr> </tbody> </table>	Battery Voltage	Low Battery Level	4.8V	4V	7.2V	6V	9.6V	8V	12V	10V	24V	20V	PWR	NO BATTERY	Li-Ion	12V
Battery Voltage	Low Battery Level																
4.8V	4V																
7.2V	6V																
9.6V	8V																
12V	10V																
24V	20V																
PWR	NO BATTERY																
Li-Ion	12V																
<p><b>PWR.FN</b> <b>(Power Function)</b></p>	<p>The Power Function sets the function of a short press of the &lt;POWER&gt; key.</p> <p>Options: NONE, UNITS</p> <p>Default: NONE</p>																

Refer to Menu Setup - SERIAL (Serial Communications Options) Page 41 and Setpoint Menu Setup - SET.PTS page 48.

#### 8.4.5. CLOC (Clock) – K35\*

CLOCK (Clock Settings) Items within this group set date and time related functions. Available

<b>FORMAT (Date Format)</b>	This sets the date format. Options are: dd.mm.yy mm.dd.yy Default: dd.mm.yy (K303 Default: mm.dd.yy)
<b>YEAR (Set Year)</b>	Range: 2000 to 2099
<b>MONTH (Set Month)</b>	Range: 01 to 12
<b>DAY (Set Day)</b>	Range: 01 to 31
<b>HOUR (Set Hour)</b>	Range: 00 to 23 (24-hour format)
<b>MINUTE (Set Minute)</b>	Range: 00 to 59

#### 8.4.6. TEST (Special Test Functions)

Items within this Group allow access to the testing routines for the instrument. With these routines the scale base output can be monitored and the inputs and outputs can be tested.

<b>SCALE (Scale Base Test Display)</b>	Verifies the correct load cell capacity and/or load cell wiring is used. It sets up the instrument as a simple test meter to measure the load cell signal output. The display reads in millivolts per volt, factory calibrated to 0.1% worst case. When accessing this item, initially there should be no weight on the scale. In OIML or NTEP modes, this display is only active for five seconds before returning to the menu.
<b>FRC.OUT (Force Outputs)</b>	Forces each of the output drivers in turn. All outputs turn OFF when leaving this step. The <EDT> key will advance through each output (ie. ON.1 and ON.2). Pressing <OK> will turn all outputs off and exit the test.
<b>O.LOAD (Overload Count)</b>	Displays a count of the number of times that the A/D conversion has been out of range since the count was last reset. This value is read only and cannot be edited.
<b>CLR.OLD (Clear Overload)</b>	

### 8.4.7. FACTRY (Factory Adjustment Menu)

Clears the A/D conversion overload counter. The instrument will prompt with Cont. N. Press <EDT> to change to Cont. Y and <OK> to continue. When Cont. Y has been chosen the instrument will display DONE to indicate that the operation has been completed. FACTRY (Factory Adjustment Menu)

<p><b>DEFLT</b> <b>(Restore Factory Settings Except for Calibration and Build)</b></p>	<p>Restores all settings in the digital setup, which are not calibration critical back to the original <b>new</b> settings installed at the factory. The main use of this routine is to completely reset an instrument that is being installed on a different scale. The instrument will prompt with <b>Cont. N</b>. Press &lt;EDT&gt; to change to <b>Cont. Y</b> and &lt;OK&gt; to continue. When <b>Cont. Y</b> has been chosen the instrument will display <b>DONE</b> to indicate that the operation has been completed.</p> <p>Restoring the factory options does not affect the calibration. To reset the calibration to factory condition CAL:FAC.CAL must be used. Refer to FAC.CAL (Restore Default Factory Calibration) ⊗ page 34. This menu item is only available when in Full Digital Setup mode.</p>
--	---

### 8.4.8. – End – (Leaving Setup)

Refer to Exiting Full or Safe Setup page 31.

## 9. Serial Outputs (K344, K35\*)

The instrument supports a bi-directional RS-232 output and temporary opto-LINK connection, allowing for a number of serial output types for communications with external devices such as printers, computers, PLCs or remote displays.

Refer to opto-LINK Activation page 16. For wiring connections and pinouts, refer to Auxiliary Connection page 11.

Serial communications is supported in firmware variants K344 and K35\*.

The instrument computer communications can range from simple automatic streamed output, through to a command-response system. In addition to the opto-LINK, the instrument can be programmed and calibrated via the RS-232 serial port. The calibration counter is incremented when the calibration related steps are accessed via RS-232, the serial port or the opto-LINK. This means that calibration via the serial port or opto-LINK cannot be carried out without affecting the certification of a trade installation.

### 9.1. Serial Output Types

There are five (5) types of serial output available and selected via (SERIAL:TYPE).

- Network Communications (NET)
  - Two network options –
  - **NET** network communications feature is normally used to control indicators remotely from a central computer, or PLC
  - Instruments can be installed in a Ring Network.
- Automatic Weight Output (AUTO)
  - The automatic output is normally used to drive remote displays, a dedicated
  - Select between two standard formats, master/slave and custom
- Single Output (SINGLE)
  - The single output produces a single output with the formats selected. It is used to drive remote displays, a dedicated computer, or PLC communications.
  - Press **<PRINT>** key to transmit in selected format.
  - A long press of the **<PRINT>** key has no effect.
  - Select between two standard formats, master/slave and custom
- Printer driving (PRINT)
  - Enables printer driving with either the standard print format or custom depending on the firmware.
- Auto Print (AUTO.PR)
  - A single printout occurs when the weight is stable after being at zero, and higher than the greater of 20 divisions or zero band.

## 9.2. NET - Network Communications

NET Protocol	<p>The <b>NET</b> network communications feature is normally used to control indicators remotely from a central computer, or PLC. A <b>NET</b> command and response might be:</p> <p><b>20110150:&lt;CR&gt;&lt;LF&gt;</b></p> <p><b>9F110150:07/01/2030 17:29&lt;CR&gt;&lt;LF&gt;</b></p>
Ring Network Enhancement	<p>Instruments can be installed in a Ring Network. This also requires the central computer to send additional framing characters, 'Echo-On' (= &lt;DC2&gt; =ASCII 12<sub>H</sub>) and 'Echo-Off' (= &lt;DC4&gt; =ASCII 14<sub>H</sub>) around each command. A Ring Network enhanced <b>NET</b> command and response might be:</p> <p><b>&lt;DC2&gt;20110150:&lt;CR&gt;&lt;LF&gt;</b></p> <p><b>&lt;DC4&gt;</b></p> <p><b>&lt;DC2&gt;20110150:&lt;CR&gt;&lt;LF&gt;</b></p> <p><b>9F110150:07/01/2030 17:29&lt;CR&gt;&lt;LF&gt;</b></p> <p><b>9E110150:07/01/2030 17:30&lt;CR&gt;&lt;LF&gt;</b></p> <p><b>&lt;DC4&gt;</b></p> <p>For more information on the <b>NET</b> Protocol and the Ring Network Enhancement, please refer to the Communications Manual.</p>

## 9.3. Auto Weight Format String

The weight format string may be set to the following formats:

Format	Description
<b>FMT_1</b>	<SIGN><WEIGHT(7)> <UNIT(L,K,G,T)>< GROSS(G,N)>< STATUS( ,M,O)>< CRLF>
<b>FMT_2</b>	<STX> <SIGN> <WEIGHT(7)> <S1> <S2> <S3> <S4> <UNITS(3)> <ETX>
<b>FMT_3</b>	<STX>< WEIGHT(8)>< GROSS(G,N)>< MOTION(M,S)>< OVERLOAD(I,O,U)><ZERO(Z,' ')>< SP SP>< ETX>
<b>FMT_4</b>	<STATUS(OL,ST,US)><GROSS(GR,NT)>< SIGN>< WEIGHT(7)>< UNITS(2)>

Where

- **STX**: Start of transmission character (ASCII 02).
- **ETX**: End of transmission character (ASCII 03).
- **SIGN**: The sign of the weight reading (space for positive, dash (-) for negative).
- **WEIGHT(7)**: A seven character string containing the current weight including the decimal point. If there is no decimal point, then the first character is a space. Leading zero blanking applies.
- **STATUS**: Provides information on the weight reading. The characters G/N/U/O/M/E represent Gross / Net / Underload / Overload / Motion / Error, respectively.
- **UNITS(3)**: A three character string, the first character being a space, followed by the actual units (eg. ^kg or ^t). If the weight reading is not stable, the unit string is sent as ^^^.

- **S1:** Displays G/N/U/O/E representing Gross / Net / Underload / Overload / Error, respectively.
- **S2:** Displays M/^ representing Motion / Stable, respectively.
- **S3:** Displays Z/^ representing centre of Zero / Non-Zero, respectively.
- **S4:** Displays - representing single range.

#### 9.4. Menu Setup - SERIAL (Serial Communications Options)

Settings within this Group determine the serial and printing outputs.

<p><b>TYPE</b> (Serial Output Type)</p>	<p>Sets the function of the first serial output. The port can be disabled or set to run as an automatic output or a network device.</p> <p>Options are:</p> <ul style="list-style-type: none"> <li>• NET: Network Communications.</li> <li>• AUTO: Enables 10 Hz automatic transmission using the format selected below (SERIAL:FORMAT).</li> <li>• SINGLE: Enables transmission on pressing the <b>&lt;PRINT&gt;</b> key using the format selected below (SERIAL:FORMAT). A long press of the <b>&lt;PRINT&gt;</b> key has no effect.</li> <li>• PRINT: Enables printer driving.</li> <li>• AUTO.PR: A single printout occurs when the weight is stable after being at zero, and higher than the greater of 20 divisions or zero band.</li> <li>• Default: NET</li> </ul>
<p><b>FORMAT</b> (Serial Output Format)</p>	<p>The Format determines the transmission format for AUTO and SINGLE serial types.</p> <ul style="list-style-type: none"> <li>• FMT_1: Format 1 Condec.</li> <li>• FMT_2: Format 2 Ranger C.</li> <li>• MASTER: Send contents of LCD display to a remote display.</li> <li>• CUSTOM: Send a custom print string to a remote display.</li> <li>• FMT_3: Gedge C2</li> <li>• FMT_4: AnD</li> </ul>
<p><b>BAUD</b> (Serial Baud Rate)</p>	<p>The baud rate determines the serial data transmission speed.</p> <ul style="list-style-type: none"> <li>• Options are: 2400, 4800, 9600,19200</li> <li>• Default: 9600</li> </ul>
<p><b>BITS</b> (Serial Format Options)</p>	<p>The Bits options allow the data transmission bit pattern and interface to be changed. The display will show the current setting in the form <b>n81-</b> where each character has a meaning as shown below.</p> <p>Options are:</p>

	<ul style="list-style-type: none"> <li>• N or O or E: Parity bit: (N) None, (O) Odd, (E) Even</li> <li>• 8, 7: Number of data bits</li> <li>• 1, 2: Number of stop bits</li> <li>• -, D: DTR handshake disabled or enabled</li> <li>• Default: n81-. (For most applications the default setting is applicable.)</li> </ul>
<b>ADDRES</b> <b>(Instrument Address)</b>	<p>Use this option to set the instrument address when operating with network communications.</p> <ul style="list-style-type: none"> <li>• Range 01 to 31</li> <li>• Default: 31</li> </ul>
<b>AUT.SPD</b> <b>Auto Output Speed)</b>	<p>Use this option to set the Auto Output Speed for the instrument. There are four speeds to choose from 10, 5, 2 &amp; 1Hz. If using a remote input Auto Output Speed must be set to 10Hz.</p>
<b>SHOW.T</b> <b>(Show Totals)</b>	<p>The <b>SHOW.T</b> item stands for <b>Show Total</b>. When enabled the total will be displayed following each printout. This can be useful if the function key is being used for another purpose.</p>
<b>RST.CON</b> <b>(Reset Printed Consecutive Number) Å</b>	<p>Use this option to reset the printed consecutive number back to <b>1</b>. The instrument will prompt with <b>Cont. N</b>. Press <b>&lt;EDT&gt;</b> to change to <b>Cont. Y</b> and <b>&lt;OK&gt;</b> to continue. When <b>Cont. Y</b> has been chosen the instrument will display <b>DONE</b> to indicate that the operation has been completed.</p>
<b>I.LOCK</b> <b>(Print Interlock)</b>	<p>Sets the type of printing interlock to be used. Options are:</p> <ul style="list-style-type: none"> <li>• NONE</li> <li>• MOTION: Printing is enabled every time the scale becomes stable.</li> <li>• RET.Z: Printing is enabled after the scale has returned to zero and is stable.</li> </ul> <p>Default: NONE</p>

## 10. Standard Printing – K344 (No Clock/Calendar)

K344 and K346 use a standard print format that includes support for printing number of pieces and samples pieces if counting is being used. Should custom printing, totalising or date and time be required, the unit can be upgraded to firmware in the K35\* range.

When the instrument has Print or Automatic print enabled the following print format is available:



121.4 kg G

Line 1: Displayed reading, units and **G** for Gross or **N** for Net.

## 11. Standard Printing – K35\* (with Clock/Calendar)

The K35\* range of firmware includes a standard print format and programmable printing. The standard print format incorporates number of pieces and totals if counting is being used.

When the instrument has Print or Automatic print enabled, the standard print format will be used or if configured, the custom print format will be used. If no programmable printing data is available then the standard printing format will be used.

Standard Printing Format:

```
000048 06/05/2003 15:10
      121.4 kg G
      43.5 kg N
      77.9 kg T
```

Line 1:

- Six (6) digit sequential number that is automatically incremented with each printing, up to a maximum of 999999.
- Current date and time, printed in the selected format.

Line 2: Displayed reading, units and **G** for Gross or **N** for Net.

Line 3: Alternate Gross or Net reading to line 2

- Net reading when the Gross reading is displayed on the second line,
- Gross reading when the Net reading is displayed on the second line.

Line 4: Tare reading when the Gross reading is displayed on the second line, and the Gross reading, units and **G** for Gross or **N** for Net.

### 11.1. Printing Number of Pieces with Counting Active

If counting is active, the printout has a fifth line for the counting information (**p** for pieces):

```
000048 06/05/2003 15:10
      121.4 kg G
      43.5 kg N
      77.9 kg T
      164 p
```

Whenever a new sample is taken when counting, the instrument prints the sample:

```
SAMPLE:    100 p = 50.0 kg
```

## 11.2. Printing Total Weight

In addition to the printout, the instrument adds the weight and pieces printed to the internal weight and count totals.

Example print format after a series of prints followed by a long press of <PRINT> key that prints totals. Note totals will be cleared and sequence number is not cleared.

```
000049 06/05/2003 15:20
          90.6 kg G
          0.0 kg.N
          0.0 kg T
000050 06/05/2003 15:21
          154.9 kg G
          0.0 kg.N
          0.0 kg T
000051 06/05/2003 15:21
          50.4 kg G
          0.0 kg.N
          0.0 kg T
000052 06/05/2003 15:21
          71.0 kg G
          0.0 kg.N
          0.0 kg T
000053 06/05/2003 15:21
          13.3 kg G
          0.0 kg.N
          0.0 kg T
ITEMS:           5
TOTAL:          380.2 kg
```

## 11.3. Printing Total Weight and Number of Pieces

Example print format when Counting is active and long press of <PRINT> key to print total number of items, weight and quantity. Note totals will be cleared and sequence number is not cleared.

```
000054 06/05/2003 15:22
          13.3 kg G
           27 p
000055 06/05/2003 15:23
          79.3 kg G
          159 p
000056 06/05/2003 15:23
          117.0 kg G
          234 p
ITEMS:           3
TOTAL:          209.6 kg
QTY:            420 p
```

## 12. Programmable Printing – K35\*

Two user determined print strings with tokens can be programmed into an instrument using View300.

### 12.1. How to set custom print strings using View 300

- Connect instrument to PC with View300
- Open full session - select instrument menu/ select custom print format.
- Edit the two custom print strings
- Hex values (such as tokens) must be preceded with a “\”.
- All hex values less than 7F<sub>H</sub> will be interpreted as ASCII characters.
- Alternatively you can use the protocols and techniques described in the “Communications Manual” to enter custom strings.

### 12.2. Tokens

Gross Weight	CF <sub>H</sub>	Current gross weight
Net Weight	DO <sub>H</sub>	Current net weight
Tare Weight	D8 <sub>H</sub>	Current tare weight
Display Weight	D9 <sub>H</sub>	Current display weight
Count	F0 <sub>H</sub>	Current count (if counting is turned on)
ID	DA <sub>H</sub>	Current print ID
Time	C0 <sub>H</sub>	Current time
Date	BF <sub>H</sub>	Current date
Total Weight	DB <sub>H</sub>	Total of printed Display Weight since last summary print (long press).
Total Count	DD <sub>H</sub>	Total number of pieces in Total Weight (if counting turned on)
Items	DC <sub>H</sub>	Number of items printed since last summary print.
Standard Print (short press)	7F <sub>H</sub>	Standard print
Standard Print (long press)	8F <sub>H</sub>	Standard summary
Streaming Register Literal	E8 <sub>H</sub>	Literal value of streaming register(s)
Streaming Register Raw	E9 <sub>H</sub>	Raw value of streaming register(s)

### 12.3. Using Tokens Example

Custom Print String definition:	Resulting Print Out:
\D9 at \C0 on \BF\0D\0A	523 kg G at 09:18 on 10/08/2006<CR><LF>

### 12.4. Clear Custom Print Strings

The menu selection FACTRY:DEFLT is used to clear the programmed printing and revert to the standard printing format.

### 12.5. Printing Custom Print Strings

Short Press <PRINT> key: to print the programmed print string up to 80 characters including tokens.

Long Press <PRINT> key: to print the programmed summary print string up to 20 characters including tokens.

### 12.6. Master Serial Output

In Master mode, the instrument sends out the entire contents of the LCD at the selected auto output speed.. This is essentially the same as AUTO output but the format of the output string is designed to allow a remote display to exactly copy the contents of the LCD including all of the annunciators and user prompts, etc.

### 12.7. Auto Output Speed

There are four speeds to choose from: 10, 5, 2 & 1Hz. If using a remote input auto output speed must be set to 10Hz.

### 12.8. Print Interlock

The print interlock (I.LOCK) sets the type of printing interlock to be used. Printing is enabled every time the scale becomes stable when MOTION is selected. Or printing is enabled after the scale has returned to zero and is stable when RET.Z is used.

## 13. Setpoints – K356

The instrument is capable of working with two internal setpoints. The status of these setpoints is displayed on the LCD. Each setpoint is associated with a physical output driver but it may also be simply used as an indicator.

### 13.1. Setpoint Menu Setup - SET.PTS

<p><b>SETPT.1</b> (Output 1 Type)</p>	<p>The type of output control associated with output 1.</p> <p>Options are:</p> <p>OFF: The output is disabled (turned off).</p> <p>ON: The output is enabled (turned on).</p> <p>OVER: The output is turned on when the source weight is over the target value and turned off otherwise.</p> <p>UNDER: The output is turned on when the source weight is under the target value and turned off otherwise.</p> <p>MOTION: The output will be driven when ever weight motion is detected.</p> <p>ZERO: The output will be driven when ever the weight motion is within the zero deadband.</p> <p>NET: The output will be driven when ever net weight is displayed.</p> <p>ERROR: The output will be driven when ever there is a diagnostic error.</p> <p>Default: OFF</p>
<p><b>SRC.1</b> (Weight Source for Output 1)</p>	<p>The weight source determines the weight reading that is used for output 1 comparisons.</p> <p>Options are:</p> <p>GROSS: Use gross weight readings always.</p> <p>DISP: Use the displayed weight (gross or net).</p> <p>NET: Use net weight readings always.</p> <p>Default: GROSS</p>
<p><b>TARG.1</b> (Target for Output 1)</p>	<p>This is the target value for output 1. This target provides the threshold value when the OVER or UNDER type options are selected.</p> <p>Range: –99999 to 999999</p> <p>Default: 000000</p>
<p><b>HYS.1</b></p>	<p>Hysteresis defines the amount of weight required for an active set point to become inactive again. HYS is the hysteresis for set point 1.</p> <p>Range: 0 to 999999</p> <p>Default: 0</p>
<p><b>SETPT.2</b> (Output 2 Type)</p>	<p>The type of output control associated with output 2.</p> <p>Options are:</p> <p>OFF: The output is disabled (turned off).</p> <p>ON: The output is enabled (turned on).</p> <p>OVER: The output is turned on when the source weight is over the target</p>

	<p>value and turned off otherwise.</p> <p>UNDER: The output is turned on when the source weight is under the target value and turned off otherwise.</p> <p>MOTION: The output will be driven when ever weight motion is detected.</p> <p>ZERO: The output will be driven whenever the weight motion is within the “zero” deadband.</p> <p>NET: The output will be driven when ever net weight is displayed.</p> <p>ERROR: The output will be driven whenever there is a diagnostic error.</p> <p>Default: OFF</p>
<p><b>SRC.2</b> (Weight Source for Output 2)</p>	<p>The weight source determines the weight reading that is used for output 2 comparisons.</p> <p>Options are:</p> <p>GROSS: Use gross weight readings always.</p> <p>DISP: Use the displayed weight (gross or net).</p> <p>NET: Use net weight readings always.</p> <p>Default: GROSS</p>
<p><b>TARG.2</b> (Target for Output 2)</p>	<p>This is the target value for output 2. This target provides the threshold value when the OVER or UNDER type options are selected.</p> <p>Range: –99999 to 999999</p> <p>Default: 000000</p>
<p><b>HYS.2</b></p>	<p>Hysteresis defines the amount of weight required for an active setpoint to become inactive again. HYS.2 is the hysteresis for setpoint 2. A value of 0 still allows for 0.5 graduations of hysteresis.</p> <p>Range: 0 to 999999</p> <p>Default: 0</p>

### 13.2. Setpoint Configuration

The SET.PTS:SETPt.1/2 settings allow output 1 and output 2 to be independently configured.

### 13.3. Setpoint Source

The SET.PTS:SRC.1/2 settings allow the gross weight, displayed weight, or net weight to be chosen as the source for the setpoint operation. This allows the overload and underload limits to be linked to gross weights always or alternatively to be linked to the current displayed weights, or the net weight.

### 13.4. Setpoint Target

The SET.PTS:TARG.1/2 values set the values for the overload and underload limits.

**1** Annunciator is displayed in the lower section of the display when the output 1 is active.

**2** Annunciator is displayed in the lower section of the display when the output 2 is active.

### 13.5. Setpoint Type (OVER/UNDER) and Hysteresis

Hysteresis defines the amount of weight required for an **active** setpoint to become **inactive** again. For an OVER setpoint it will be the amount the weight must fall below the target to turn off. For an UNDER setpoint it will be the amount of weight that it goes over the target by for the (already active) output to turn off. A value of 0 still allows for 0.5 graduations of hysteresis.

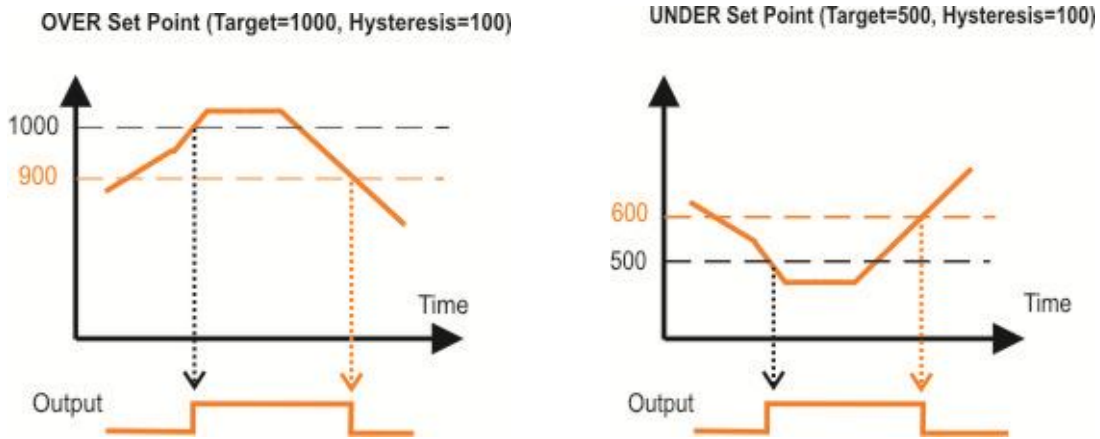

## 14. Special Functions Key – K35\*

### 14.1. Introduction

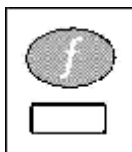

The K35\* firmware allows for the <FUNCTION> key to be configured to a range of special functions. As the K356 firmware allows for setpoints, there is an additional special function available where the key can be used to gain access to the setpoint threshold values.

Refer to KEY.FN

(Key Functions) page 35 to configure the function key.

When leaving the factory, the <FUNCTION> key is blank and has no function pre-programmed. Each function has an associated overlay sticker supplied that should be applied to the function key to label the function. Ensure the keypad is clean and dry before affixing the sticker. Refer to Cleaning page 8 for more information.

### 14.2. Key Functions

#### 14.2.1. NONE

When set to **NONE** the special function key is not used during normal operation. This is the default setting.

#### 14.2.2. TEST

Press the <TEST> key to clear the display then show all segments of the display then clear the display again before returning to normal operation.

#### 14.2.3. COUNT

Use this key to perform pieces counting. Press the <COUNT> key to switch between weight display and counts display. The instrument annunciator shows **p** for pieces.

To record a new sample do the following:

Tare off any containers.
Place the sample on the scale
Press and hold the <COUNT> key for two seconds. The default number of items in the sample will be displayed.
Use the <SEL> and <EDT> keys to alter the number of items.
Press <OK> and the current sample will be stored against the entered items.
If printing is enabled the sample quantity and weight will be printed.

#### 14.2.4. UNITS

Use the <UNITS> key to switch the displayed reading between **lb** and **kg**. This will affect the displayed and printed weight but will not affect any data entry. The following is a sample of a printout displaying kg and lb.

```
000009 06/05/2003 16:31
          2.8 kg G
000010 06/05/2003 16:31
          6.1 lb G
```

### 14.2.5. HOLD and PEAK HOLD

The **<HOLD>** key implements a manual **Hold** function. The **<PEAK>** key implements a **Peak Hold** function where the largest absolute weight, either positive or negative is stored in the peak value (eg. -30 is larger than 25). The **Hold** annunciator is active when the display is showing the held weight. Refer to 5.1 Display page 20.

To perform the **Hold** function, do the following:

Press the manual <b>&lt;HOLD&gt;</b> key once to hold the current displayed weight.
---

Press the manual <b>&lt;HOLD&gt;</b> key again to return the display to normal weighing.
--

To perform the **Peak Hold** function do the following:

Press the <b>&lt;PEAK&gt;</b> hold key once to show the absolute peak weight reading.
---

Press the <b>&lt;PEAK&gt;</b> hold key again to return the display to normal weighing.
--

A long press of the <b>&lt;PEAK&gt;</b> hold key clears the peak value back to <b>0</b> (zero).
---

All printouts that print the displayed weight will use the held weight reading if it is currently being displayed. K303 will not print while a weight is held.

### 14.2.6. SHOW.T

The **SHOW.T** item stands for **Show Total**. The function key will be labelled **<TOTAL>**.

The **PRINT** key is used not only to print the current weight but also to add that weight to the current total.

When the <b>&lt;TOTAL&gt;</b> key is pressed the indicator displays <b>count</b> followed by the number of items in the total.
--

After this, <b>TOTAL</b> is displayed followed by the current total weight.
---

If the total weight is too large to display in six digits, the weight is shown in two sections labelled with the upper six digits displayed before the lower six digits.

A long press of the **<PRINT>** key causes the total accumulated weight to be printed and then cleared. The SERIAL:TYPE option must be set to PRINT to activate this function.

### 14.2.7. HI.RES

The **<HI.RES>** key is used to switch the display between normal and a high resolution (x10) display of the weight. The high resolution display is identified by flashing units.

### 14.2.8. A.TARE

The **<A.TARE>** key is used to enable the automatic tare feature. This feature when enabled will cause the indicator to be tared whenever the weight is motionless above the autotare threshold and has been below the autotare threshold since the last autotare. The tare weight is reset to zero when the autotare feature is active and the gross weight is motionless within the zero "dead" band.

Press the <b>&lt;A.TARE&gt;</b> key to switch between normal weighing and automatic tare mode. An ► annunciator will appear in the middle of the right hand side of the display to indicate that the automatic tare mode is active.
--

Press and hold the **<A.TARE>** key to set the threshold above which the automatic tare occurs.

Press the **<OK>** key to enter the automatic tare threshold. Change the threshold to the required value using the **<SEL>** and **<EDT>** keys.

Press the **<OK>** key to store the new automatic tare threshold. When the process is complete the display will return to weight.

Automatic tare mode the following sequence is typically followed:

The threshold is set to below the minimum box weight.

After the instrument has been zeroed, the instrument shows the current gross weight.

While the gross weight is below the threshold, the instrument shows the current gross weight.

A box is placed on the scale. When the displayed gross weight is stable above the threshold weight. The instrument will automatically tare and the net weight of zero will be displayed.

The box is filled with the instrument displaying the net weight.

The filled box is removed from the scale.

When the gross weight is stable within the zero 'dead' band the instrument will automatically zero and the gross weight of zero will be displayed.

The next box can be placed on the scale and the process repeated.

#### 14.2.9. SET.PT (K356)

The **<SET.PT>** key is used to gain access to the setpoint threshold values. A short press of the key displays the threshold values while a long press enables editing of the threshold values.

A short press the **< SET.PT >** key will display “**SetPt.1**”, followed by the output 1 target, followed by “**SetPt.2**”, followed by the output 2 target

Press and hold the **< SET.PT >** key to edit the target threshold associated with output1. The “**SetPt.1**” annunciator appears briefly on the display before editing mode is entered to indicate that the output 1 threshold is being edited.

Press the **<OK>** key to enter the output 1 threshold. Change the threshold to the required value using the **<SEL>** and **<EDT>** keys.

Press the **<OK>** key to store the new output 1 threshold. When the process is complete the display will move on to editing the output2 threshold.

The “**SetPt.2**” annunciator appears briefly on the display before editing mode is entered to indicate that the output 2 threshold is being edited.

Press the **<OK>** key to enter the output 2 threshold. Change the threshold to the required value using the **<SEL>** and **<EDT>** keys.

Press the **<OK>** key to store the new output 2 threshold. When the process is complete the indicator will revert to the condition it held prior to the initial pressing of the **< SET.PT >** key.

## 15. Appendix - Trade Sealing Details

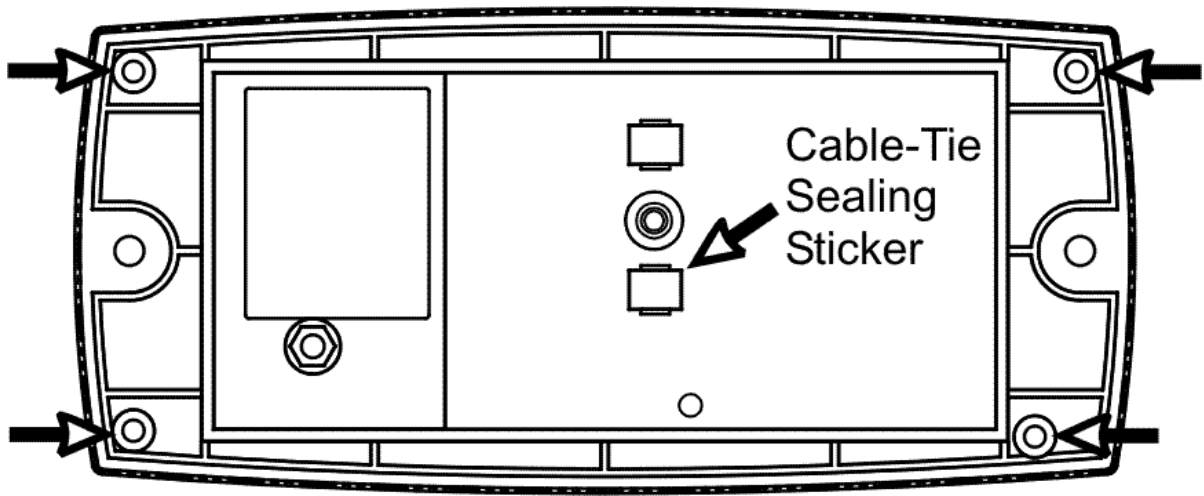

Affix sealing stickers to the rear of the instrument, over one or more screws in the locations indicated.

Also affix a sealing sticker over the load cell cable where the cable-tie strain relief is attached, as indicated.

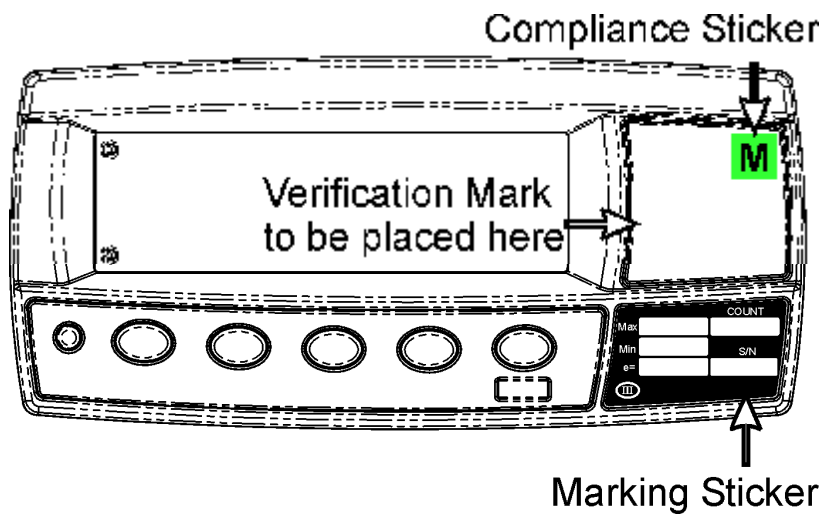

Affix stickers in the locations indicated.

## 16. Appendix – ABS R320 Dimensions

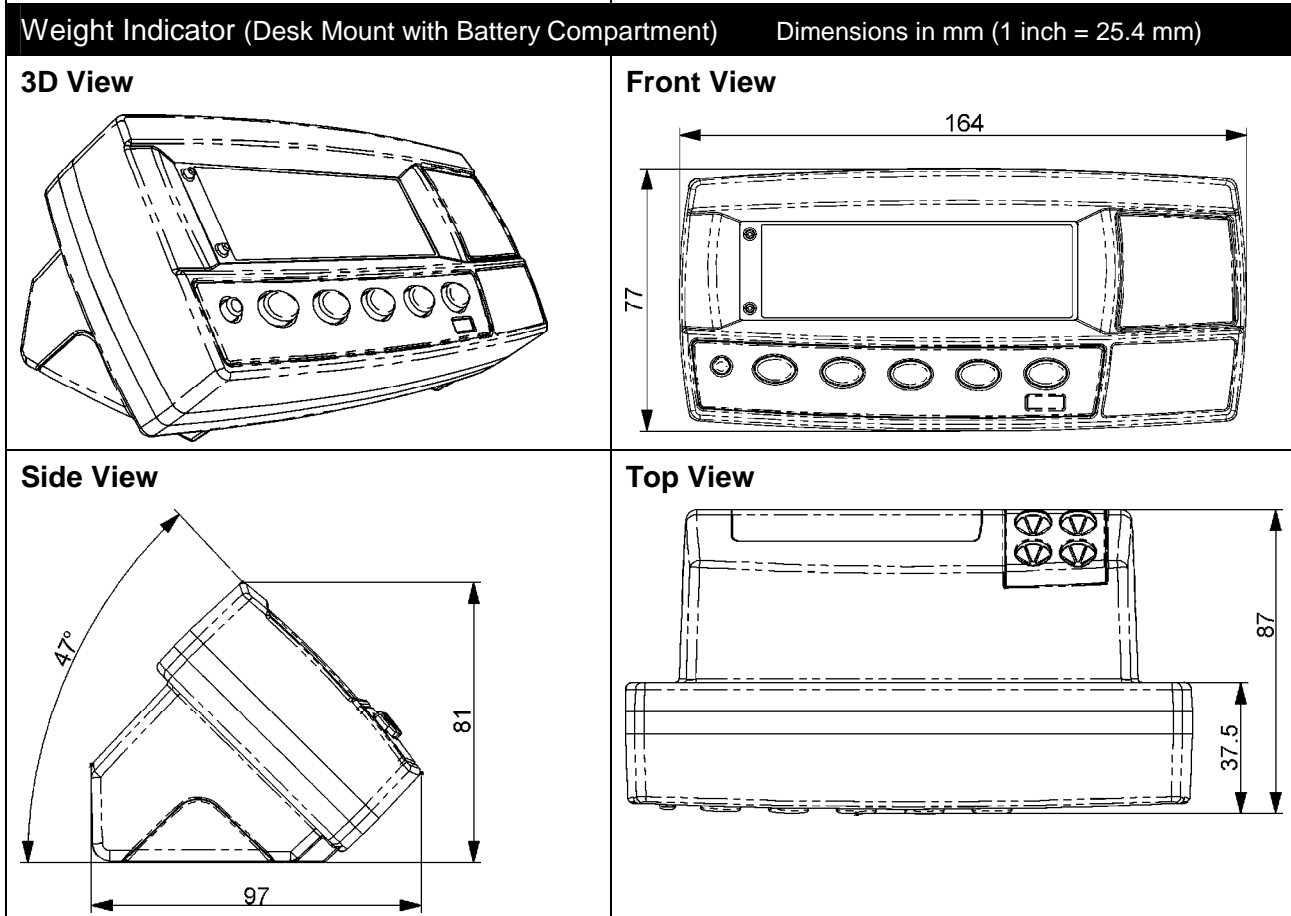
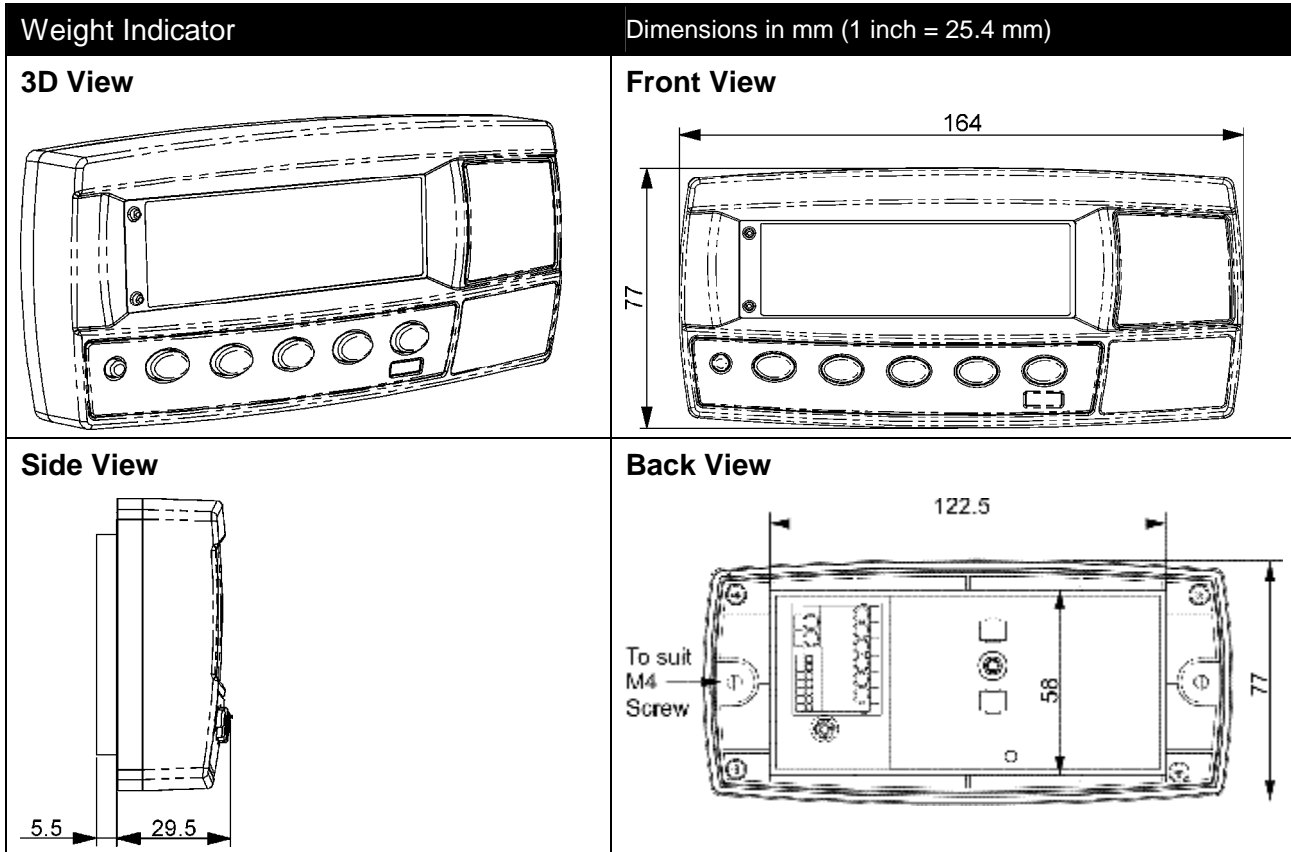

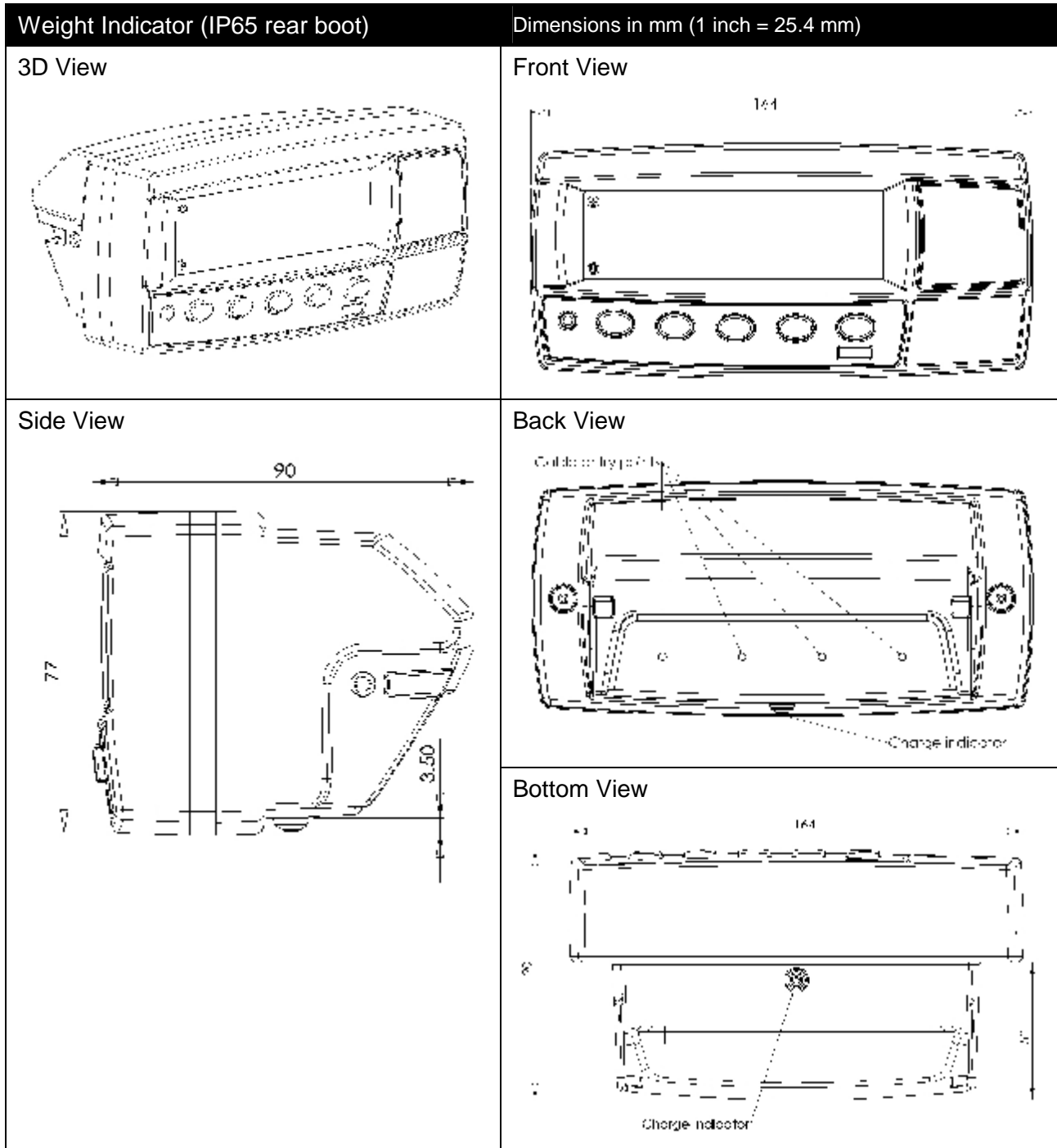

# 17. Appendix – Stainless Steel R323 Dimensions

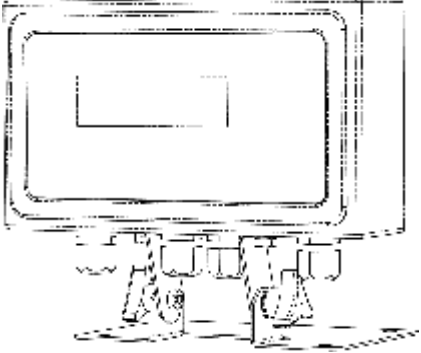
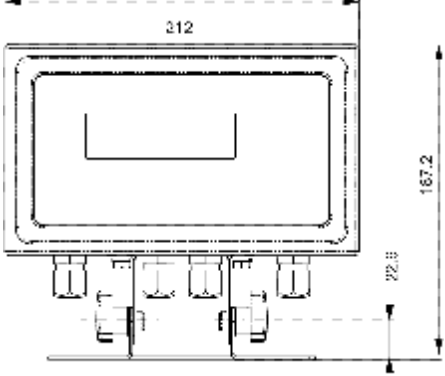
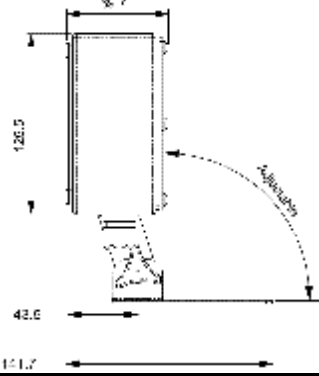
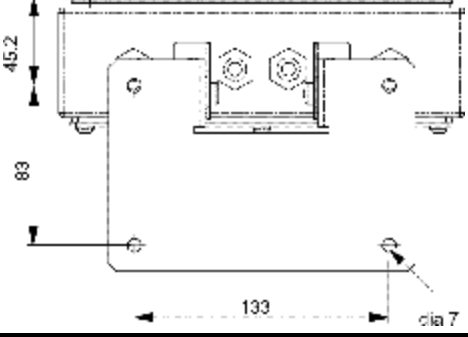
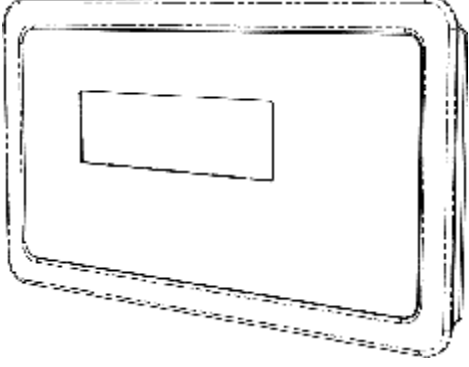
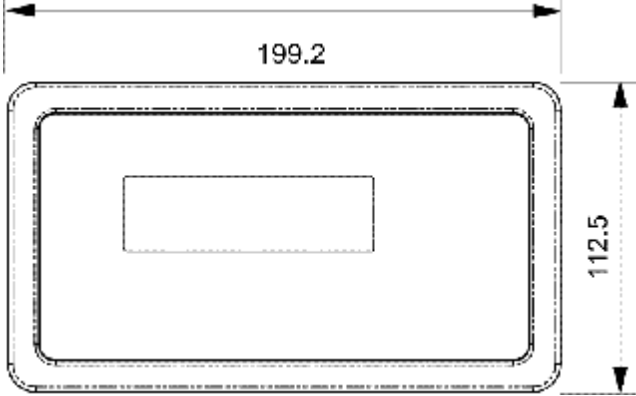
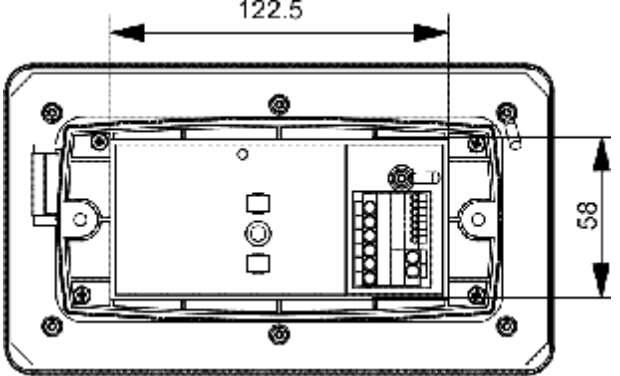
Weight Indicator (Desk Mounted)		Dimensions in mm (1 inch = 25.4 mm)	
<p><b>Desk Mounted 3D View</b></p> 	<p><b>Front View</b></p> 		
<p><b>Side View</b></p> 	<p><b>Bottom View</b></p> 		
Weight Indicator (Panel Mounted)		Dimensions in mm (1 inch = 25.4 mm)	
<p><b>Panel Mounted 3D View</b></p> 	<p><b>Front View</b></p> 		
	<p><b>Rear View</b></p> 		

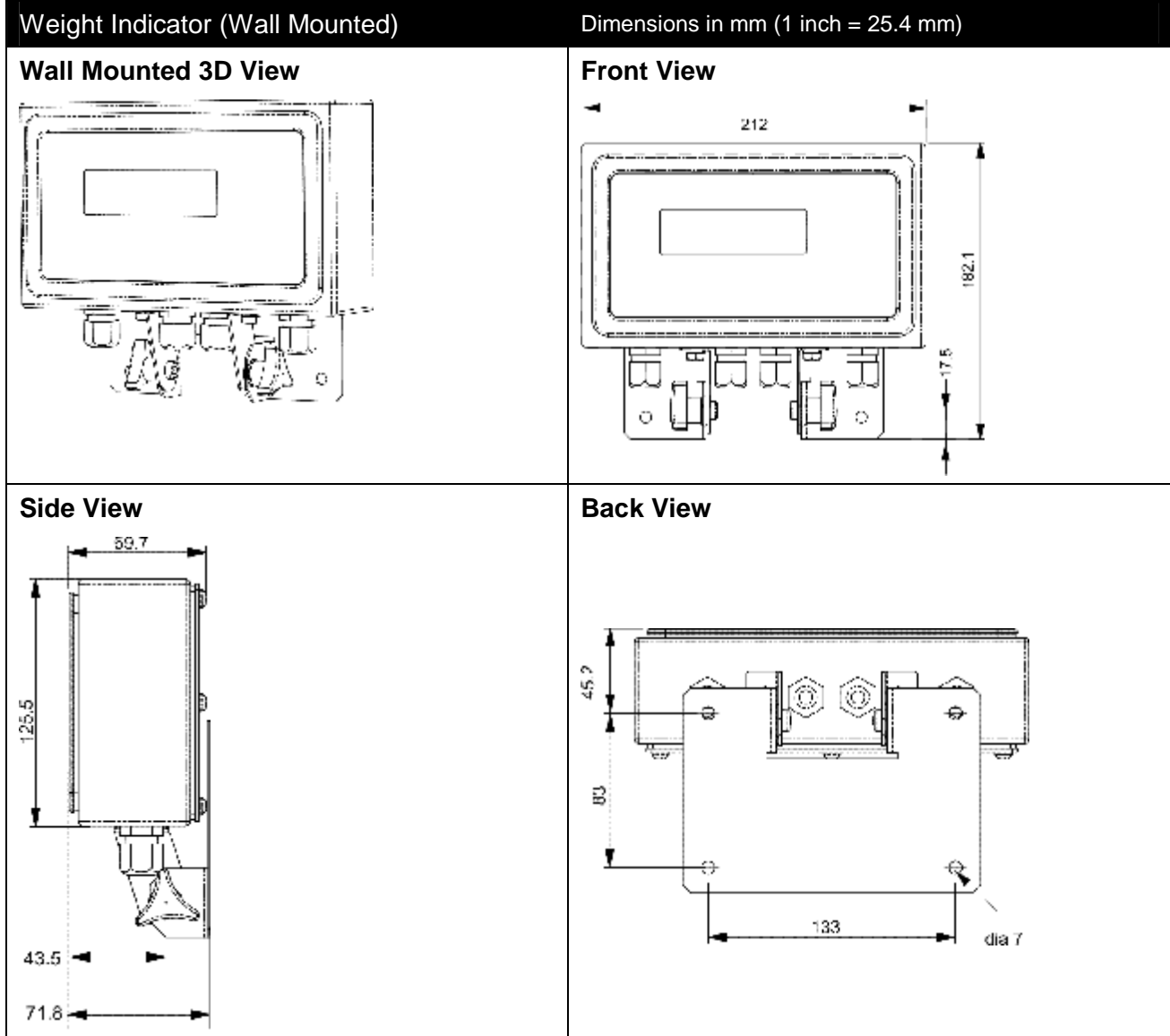

## 18. Setup Menu Quick Reference

**Note:** ⊗ Available only in Full Setup. Changing this setting **will increment** the Calibration Counter.

1 Available only in Full Setup. Changing this setting **will not increment** the Calibration Counter.

Group (GRP)	Item (ITM)	Page	⊗
<b>BUILD</b>	DP (Decimal Point Position) Ä	32	⊗
	CAP (Maximum Capacity) Ä	32	⊗
	RES (Count-by Resolution) Ä	32	⊗
	UNITS (Weighed Units) ⊗	32	⊗
	HI.RES (High Resolution x 10 mode) Ä	32	⊗
	CABLE (4-Wire or 6-Wire) Ä	32	⊗
	<b>OPTION</b>	USE (Scale Use) Ä	33
FILTER (Reading Average)		33	
MOTION (Motion Detection) ⊗		33	⊗
INIT.Z (Initial-Zero on <b>Startup</b> )		33	
Z.TRAC (Zero Tracking Sensitivity) Ä		33	⊗
Z.RANGE (Allowable Zero Operating Range) ⊗		33	⊗
Z.BAND (Zero 'Dead' Band) Ä		33	
R.ENTRY (Entry Means to Full Setup)		33	⊗
<b>CAL</b>	ZERO (Zero Calibration) ⊗	34	⊗
	SPAN (Span Calibration) ⊗	34	⊗
	DIR.ZER (Direct Zero Calibration) ⊗	34	⊗
	DIR.SPN (Direct Span Calibration) ⊗	34	⊗
	FAC.CAL (Restore Default Factory Calibration) ⊗	34	⊗
<b>SPEC</b>	SAFE.PC (Safe Security Passcode for Digital <b>Setup</b> )	34	
	FULL.PC (Full Security Passcode for Digital <b>Setup</b> )	35	1
	KEY.LOC (Front Panel Key Locking)	35	
	KEY.FN	35	

	(Key <b>Functions</b> )		
	AUT.OFF (Auto Power Off / Battery <b>Operation</b> )	35	
	B.LIGHT (Backlight Operation)	35	
	REM.FN (Remote Function)	36	
	REM.CHR (Remote Input Transmit Idle Character)	36	
	BAT.VLT (Battery Voltage)	36	
	PWR.FN (Power Function)	36	
<b>SERIAL</b>	TYPE (Serial Output Type)	41	
	FORMAT (Serial Output Format)	41	
	BAUD (Serial Baud Rate)	41	
	BITS (Serial Format Options)	41	
	ADDRES (Instrument Address)	41	
	AUT.SPD Auto Output Speed)	41	
	SHOW.T (Show Totals)	41	
	RST.CON (Reset Printed Consecutive Number) ⊗	41	⊗
	I.LOCK (Print Interlock)	42	
<b>SET.PTS</b>	SETPT.1 (Output 1 Type)	48	
	SRC.1 (Weight Source for Output 1)	48	
	TARG.1 (Target for Output 1)	48	
	HYS.1 (Hysteresis 1)	48	
	SETPT.2 (Output 2 Type)	48	
	SRC.2 (Weight Source for Output 2)	48	
	TARG.2 (Target for Output 2)	48	
	HYS.2 (Hysteresis 2)	48	
<b>CLOC</b>	FORMAT (Date Format)	37	
	YEAR (Set Year)	37	
	MONTH (Set Month)	37	
	DAY (Set Day)	37	
	HOUR (Set Hour)	37	
	MINUTE (Set Minute)	37	
<b>TEST</b>	SCALE (Scale Base Test Display)	37	
	FRC.OUT (Force Outputs)	37	
	O.LOAD(Overload Count)	37	
	CLR.OLD (Clear Overload)	37	
<b>FACTRY</b>		38	1
<b>- END -</b>	Save settings and return to normal weighing mode. Refer to Exiting Full or Safe Setup	31	

## 19. Error Messages

A number of error messages may be displayed to warn of operation outside of the acceptable limits. These messages are described below. Short messages (XXXXX) will appear as a single message on the display. Longer messages (XXXXX) (YYYYY) will appear on the display in two parts, first the (XXXXX) part, then the (YYYYY) part.

### 19.1. Weighing Errors

These messages show status messages or errors that may occur during normal weighing operation.

Error	Description	Resolution
(U - - - -)	The weight is below the minimum allowable weight reading.	Increase the weight or decrease the minimum allowable weight reading.
(O - - - -)	The weight is above the maximum allowable weight reading. Warning - overloading may damage mechanical scale elements.	Check the condition of load cell connections. Check for damaged load cell.
(ZERO) (ERROR)	The weight reading is beyond the limit set for Zero operation. The operation of the <ZERO> key is limited in the setup during installation. The indicator cannot be Zeroed at this weight.	Increase the Zero Range (Z.RANGE) or use the <TARE> key instead.
(STABLE) (ERROR)	Scale motion has prevented a <ZERO> or <TARE> operation from occurring on command.	Try the operation again once the scale is stable.

## 19.2. Setup and Calibration Errors

These messages show status messages or errors that may occur during the instrument setup and calibration.

Error	Description	Resolution
(ENTRY) (DENIED)	The instrument may be in Safe Setup and an item that needs Full Setup has been selected for editing.	Access Full Setup to edit the item.
	When accessing setup, more than three attempts have been made with the incorrect passcode. Refer to Setup Lock-Out page 26 for more information.	Turn the instrument off. When the instrument is turned back on, enter the correct passcode to access setup.
(PT.TOO) (CLOSE)	An attempt has been made to place a calibration point too close to an existing calibration point.	Re-enter the calibration point. Points must be spaced by at least 2% of full scale from each other.
(RES) (LO)	The scale build is configured for less than 100 graduations.	Check the resolution (count-by) and capacity settings.
(RES) (HIGH)	The scale build is configured for more than 30,000 graduations.	Check the resolution (count-by) and capacity settings.
(SPAN) (LO)	The load cell signal range (span) is too small for these settings.	Incorrect span weight entered (must be between zero and full scale). Scale wiring incorrect. Wrong load cell capacity (too large). Wrong or no calibration weight added to scale.
(SPAN) (HI)	The load cell signal range (span) is too large for these settings.	Incorrect span weight entered (must be between zero and full scale). Scale wiring incorrect. Load cell capacity too small for application.
(ZERO) (LO)	An attempt has been made to calibrate zero below -2mV/V.	Scale wiring incorrect
(ZERO) (HI)	An attempt has been made to calibrate zero above +2mV/V.	Remove all weight from scale. Scale wiring incorrect.

### 19.3. Diagnostic Errors

The instrument continually monitors the condition of the internal circuits. Any faults or out-of-tolerance conditions are shown on the display as an **E** type error message.

In the table below the following terms are used:

- **Check:** This item can be checked on site by service personnel.
- **Return for Service:** The instrument must be returned to the manufacturer for factory service.

Error	Description	Resolution
(E0001)	The power supply voltage is too low.	Check supply
(E0002)	The power supply voltage is too high.	Check scale / cables
(E0010)	The temperature is outside of allowable limits.	Check location
(E0020)	Scale build is incorrect. The number of graduations has been set too low or too high.	Fix up scale build
(E0100)	The digital setup information has been lost.	Re-enter setup
(E0200)	The calibration information has been lost.	Re-calibrate
(E0300)	All setup information has been lost	Enter setup and calibrate
(E0400)	The factory information has been lost.	Return for Service
(E0800)	The EEPROM memory storage chip has failed	Return for Service
(E2000)	ADC Out of Range Error. This may be caused from a broken load cell cable.	Check BUILD:CABLE setting. Check load cell cable, wiring, etc.
(E4000)	The battery backed RAM data has lost data.	Re-enter setup
(E8000)	The FLASH program memory is incorrect	Return for Service

The **E** type error messages are additive. For example if instrument is running off batteries and the temperature drops, the battery voltage may be too low. The resulting error messages will be **E 0011** (0001 + 0010). The numbers add in hexadecimal as follows:

**1 - 2 - 3 - 4 - 5 - 6 - 7 - 8 - 9 - A - B - C - D - E - F**  
(For example, 2 + 4 = 6, or 4 + 8 = C)

## 20. Appendix - rinWIRE Protocol

The protocol uses ASCII characters with a single master POLL / RESPONSE message structure. All information and services are provided by registers each of which has its own register address.

### Basic Message Format

The basic message format is as follows:

<b>ADDR</b>	<b>CMD</b>	<b>REG</b>	<b>:</b>	<b>DATA</b>
<i>Header</i>				<i>Data</i>

### ADDR

ADDR is a two character hexadecimal field corresponding with the following:

ADDR	Field Name	Description
80 <sub>H</sub>	Response	'0' for messages sent from the master (POLL). '1' for messages received from a module (RESPONSE)
40 <sub>H</sub>	Error	Set to indicate that the data in this message is an error code and not a normal response.
20 <sub>H</sub>	Reply Required	Set by the master to indicate that a reply to this message is required by any slave that it is addressed to. If not set, the slave should silently perform the command.
00 <sub>H</sub> .. 1F <sub>H</sub>	Module Address	Valid addresses are 01 <sub>H</sub> to 1F <sub>H</sub> (1 .. 31). 00 <sub>H</sub> is the broadcast address. All sensors must process broadcast commands. When replying to broadcasts, sensors reply with their own address in this field.

**Note:** The hexadecimal codes are combined in the fields described above when multiple options are active at the same time. For example an error response message from sensor address 5 would have an ADDR code of C5<sub>H</sub> (80<sub>H</sub> + 40<sub>H</sub> + 05<sub>H</sub>).

**CMD** is a two character hexadecimal field:

CMD	Command	Description
05 <sub>H</sub>	Read Literal	Read register contents in a 'human readable' format
11 <sub>H</sub>	Read Final	Read register contents in a hexadecimal data format
12 <sub>H</sub>	Write Final	Write the DATA field to the register.
10 <sub>H</sub>	Execute	Execute function defined by the register using parameters supplied in the DATA field.

**REG** is a four character hexadecimal field:

REG	Register	Description
0005 <sub>H</sub>	Serial Number	Returns sensor serial number
0020 <sub>H</sub>	ADC Sample Number	Read current sample number since last power on. (32 bit)
0021 <sub>H</sub>	System Status	This register can be read to obtain the status of the instrument. 32 status bits sent as 8 hex chars, where: 00020000 <sub>H</sub> : Overload 00010000 <sub>H</sub> : Underload 00008000 <sub>H</sub> : Error (see System Error) 00004000 <sub>H</sub> : SETUP menus active 00002000 <sub>H</sub> : Calibration in progress 00001000 <sub>H</sub> : Motion 00000800 <sub>H</sub> : Centre of Zero 00000400 <sub>H</sub> : Zero 00000200 <sub>H</sub> : Net
0022 <sub>H</sub>	System Error	Diagnostic Errors
0023 <sub>H</sub>	Absolute mV/V	Absolute mV/V reading where 10000 = 1.0mV/V
0025 <sub>H</sub>	Displayed Weight	Gross or Net weight depending on which is active
0026 <sub>H</sub> 0027 <sub>H</sub> 0028 <sub>H</sub>	Gross,Net,Tare Weight	Gross Net or Tare weights

**:DATA** carries the required information for the message

:	‘:’ (COLON) character is used to separate the header (ADDR CMD REG) and DATA information.
<b>DATA</b>	Carries the information for the message. Some messages require no DATA (eg Read Commands) so the field is optional.

Termination

Message termination is possible in two ways.

8 : For normal communications that do not involve checksums use either a CRLF (ASCII 13, ASCII 10) as a terminator or a semicolon (; ASCII ). There is no start-of-message delimiter:

<Message> 8

### Ring Network Enhancement

Instruments with software revision V2.31+ can be configured in a Ring Network via a M42xx module (software revision 1.01+). This requires the central computer to send additional framing characters, ‘Echo-On’ (= <DC2> = ASCII 12 H) and ‘Echo-Off’ (= <DC4> = ASCII 14 H) around each command. Below is an example Ring Network command and response with two indicators:

#### COMMAND

```
<DC2>20110150:<CR><LF>
<DC4>
```

#### RESPONSE

```
<DC2>20110150:<CR><LF>
81110150:07/01/2030 17-29<CR><LF>
82110150:07/01/2030 17-30<CR><LF>
<DC4>
```

## 21. Glossary Terms

Term	Definition
<b>COMM</b>	The communications protocol used to communicate with the R300 Series
Count-by	The smallest change in weight units that the display can show. See also Resolution.
Division	A single graduation.
EEPROM	Electrically Erasable Programmable Read-Only Memory
EMC	Electro-Magnetic Compatibility Regulation
FIR	Finite Impulse Response
Full Scale	The maximum gross weight allowed on the scale. This is used to detect overload and underload conditions, etc.
Graduations	The maximum number of display steps between zero gross load and full capacity gross load. It is equal to the full scale divided by the resolution.
LED	Light Emitting Diode
NTEP	National Type Evaluation Program
OIML	International Organization of Legal Metrology
opto-LINK Cable	opto-isolated infrared communications link cable
PLC	Programmable Logic Controller
Range	Total change in weight between zero gross load and full capacity gross load (ie. the nominated total capacity of the scale). It is always given in displayed weight units.
Resolution	The smallest change in weight units that the display can show. See also Count-by.
RFI	Radio Frequency Interference
Ring Network	A network of up to 31 Instruments connected to a central computer
RS-232	Standard for communications hardware layers.
Step-Response	The step-response is the time between placing a weight on the scale and the correct weight reading being displayed.
Transients	A temporary voltage oscillation or spike caused by a sudden change of load (or other external influence).
Units	The actual units of measurement (kilograms, tonnes, pounds, etc.).

### 21.1. List of Figures

Figure 1: Weight Indicator .....	5
Figure 2: Cable Connections .....	9
Figure 3: 4-Wire Connections.....	10
Figure 4: 6-Wire Connections.....	10
Figure 5: RS-232 – One Instrument to PC using COM Port (DB9) .....	11
Figure 6: RS-232 – One Instrument to PC using COM Port (DB25).....	11
Figure 7: RS-232 Short Cable Runs: Ring Network using COM Port (DB9).....	12
Figure 8: RS-232 Long Cable Runs: Ring Network using COM Port (DB9) .....	13

---

Figure 9: RS-232 – Instrument to Printer (DB25).....	14
Figure 10: Remote Input.....	14
Figure 11: Instrument Outputs to Drive Relay.....	15
Figure 12: Instrument Outputs to Drive PLC.....	15
Figure 13: opto-LINK Attachment.....	16
Figure 14: Cable Shield Connection.....	17
Figure 15: Editing Annunciators.....	18
Figure 16: Display and Controls Illustration.....	20
Figure 17: Chart - Zero and Span Points to Interpolate Weight from Load Cell.....	28

## 21.2. List of Tables

Table 1: Industrial vs OIML and NTEP Modes.....	25
---	----

## 22. Index

- 4**  
4-Wire Connection, 10
- 6**  
6-Wire Connection, 10
- A**  
**ADDRES**, 42, 60  
**AUT.OFF**, 35, 36  
AUT.SPD, 42  
Automatic Weight Output, 39, 43, 44  
Auxiliary Connection, 11, 39
- B**  
**B.LIGHT**, 35, 60  
Basic Weighing Terminology, 24  
**BAUD**, 41, 60  
**BITS**, 41, 60
- C**  
**CABLE**, 9, 10, 32, 59  
Cable Connections, 9  
CAL, 34  
Calibration, 28  
Calibration Counter, 25  
**CAP**, 32, 59  
CLOCK, 37  
COMM Protocol, 40  
Communications Manual, 6  
Connecting Shields, 17  
COUNT, 51
- D**  
Data Entry, 18  
    Numeric Entry, 19  
    Selections and Options, 19  
**DAY**, 37  
DC Power Supply, 9  
**DEFLT**, 37, 38, 60  
Diagnostic Errors, 63  
Digital Calibration with Test Weights, 28  
**DIR.SPN**, 34, 59  
**DIR.ZER**, 34, 59
- Direct mV/V Calibration, 29  
Direct Span Calibration, 29  
Direct Zero Calibration, 29  
Document Conventions, 6  
**DP**, 32, 59
- E**  
Earthing, 17  
Editing Annunciators, 18, 21  
Electrical Safety, 8  
EMC Immunity, 8  
End – Leaving Setup, 38  
Error Messages, 61  
Exiting Digital Setup, 38, 60  
Exiting Full or Safe Setup, 31
- F**  
**FAC.CAL**, 34, 38, 59  
**FILTER**, 33  
FILTER (Reading Average), 59  
Filtering Techniques, 25  
**FORMAT (Date)**, 37, 60  
**FRC.OUT**, 37, 60  
Full Digital Setup Passcode, 34  
Full Setup Passcode, 26  
**FULL.PC**, 34, 36  
FUNCTION Key, 51  
Function Keys  
    Editing Function, 21  
    Primary Function, 21
- G**  
General Setup Information, 24  
Glossary of Terms, 67  
GROSS/NET Key
- opto-LINK  
    Activation, 22, 23  
Group and Items, 31
- H**  
**HI.RES**, 32, 59  
HOLD, 52  
**HOURL**, 37
- I**  
Industrial vs OIML and NTEP Mode, 25  
**INIT.Z**, 33, 59
- K**  
Key Functions, 51  
**KEY.FN**, 35, 51, 59  
**KEY.LOC**, 35  
Keypad  
    Normal Operation, 18
- L**  
LIVE.WT, 52, 53  
Load Cell Connection, 9  
Load Cell Signals, 9
- M**  
Master Serial Output, 46, 47  
**MINUTE**, 37  
**MONTH**, 37  
**MOTION**, 21, 33, 59
- N**  
NONE, 51  
NVRAM, 5
- O**  
OPTION, 33  
OPTION (Scale Options), 21  
opto-LINK, 16  
Outputs, 15
- P**  
Passcode, 24  
PEAK HOLD, 52  
POWER Key, 21  
**Automatic Operation**, 21  
PRINT Key, 23
- Printing  
    Counting Sample, 44  
    Gross or Net, 43, 44
- R**  
Reference Manual, 6  
**REM.FN**, 36  
Remote Function, 14, 36  
Remote Input, 14  
**RES**, 32, 33, 59  
**Restore Factory Settings**, 37, 38, 60  
RFI, 67  
Ring Network Enhancement, 40  
RS-232 Serial, 11  
**RST.CON**, 42, 60
- S**  
S.in P, 29, 34  
Safe Setup Passcode, 26  
**SAFE.PC**, 34  
SCALE, 9  
**SCALE (Scale Base Test Display)**, 37, 60  
Scale Build, 9, 34  
Sealing Details, 54  
Sealing Requirements, 17  
SERIAL, 41  
Serial Output, 39  
Serial PC Link, 11, 12  
Serial Printer Connections, 14  
Serial Remote Display, 14  
Setpoint Operation, 49  
Setpoints, 48  
Setup Display Prompts, 31  
Setup Errors, 62  
Setup Menu Quick Reference, 59  
SHOW.T, 52

---

Sigma-Delta A/D converter, 5	<b>T</b>	Units Display, 20	Z.in P, 29, 34
<b>SPAN</b> , 34, 59	TARE Key, 22	USE, 25, 33, 59	Z.RANGE, 22, 33, 59
Span Calibration Routine, 29	TARG.HI, 48, 49, 60	<b>W</b>	<b>Z.TRAC</b> , 33, 59
SPEC, 34	TEST, 51	Weighing Errors, 61	<b>ZERO</b> , 34, 59
Special Functions, 51	TEST (Special Test Functions), 37	Weight Display, 20	Zero Calibration Routine, 29
Specifications, 6, 7	<b>TYPE (Serial Output)</b> , 41, 60	<b>Y</b>	ZERO Key, 22
SRC, 48, 49, 60	<b>U</b>	<b>YEAR</b> , 37	
Stability Considerations, 21	<b>UNITS</b> , 32, 51, 59	<b>Z</b>	
		<b>Z.BAND</b> , 33, 59	